

## **Automated Control of Chicken Environment and Egg Production**

**Titilope Z. Alagun and Dr. Shahryar Darayan**

Department of Engineering Technologies  
Texas Southern University  
Houston, TX 77004

### **Abstract**

This paper will discuss the design of a Fully-Automated Prototype Chicken Farm. The project has been completed and tested to work properly. The aim of this project is to utilize a computer to control the living environment of chickens and transport the chicken eggs from the nest to the separator unit where the eggs would be separated based on their height using relay switches. The units controlled by the relay ports connected to the computer include the Light Unit, Food Supply Unit, Water Supply Unit, and Fan Unit. The software for this program is written in C language. The egg separation unit will be powered from a dc power supply and consists of three main parts which are Egg Conveyor unit, Egg Separator, and controlling unit. The Egg Conveyor transports the eggs from the nest to the conveyor. The Egg Separator unit is made of a ramp which inclines for the big size eggs and remains flat for the small size eggs. The Controlling unit will adjust the level of Egg Separator Unit based on the height of the egg. The automated chicken farm unit also has a Solar Unit that extracts and converts energy from the sun to electrical energy. This energy is used to power the chicken farm and also used to charge a battery for future use. This project would benefit both small and large scale chicken farms by reducing cost of operation, manual labor, and increasing productivity.

### **Introduction**

By the 1900's, an average chicken farm was an extension of the family kitchen. Most of the chicken farms were usually owned and operated by families and had no automation. Very few sold poultry products. Chickens were used for the same purpose as they are now which includes meat, eggs, and money. Most chicken or poultry farms today are owned and operated by companies and machines perform several tasks on the chicken farms since production is large scale. The use of automated machines in the production process is being incorporated. For example, there are automated machines for washing eggs<sup>1</sup>, special machines for breaking eggs<sup>2</sup>, egg cleaning, sorting, and grading machines<sup>3</sup>, defeathering machines for birds<sup>4</sup>, automatic water bowls and troughs<sup>5</sup>, and machines capable of catching and caging chickens<sup>6</sup>. By the early 1900's, the number of broilers in produced in the United States averaged about 100 million. In a century, with the help of technological inventions, poultry farms have grown tremendously such that more work can be done in less time. Statistics from the United States Department of Agriculture

shows that by 2000, the number of broilers produced in the United States has grown to over 8 billion<sup>7</sup>.

This paper discusses the design of the fully Automated Prototype Chicken Farm Unit which combines an automated feeder, water, light, and temperature systems in a single chicken house and the Automated Egg Conveyor and Separator unit used to automatically transport the eggs from the nest to the separator.

The chicken farm systems are controlled by conditions set on the computer programs. The different units were controlled by the relay ports. The relays operated as switches to turn on or off the unit connected to that particular relay port. The automated chicken farm unit has a solar unit that extracts and converts energy from the sun to electrical energy. This energy is used to charge a battery which is used to power the chicken house. The solar unit has a single axis solar tracker that enables the solar panel to move from east to west in the direction of the sun and controls the alignment of the solar panel with the sun to obtain maximum energy transfer. The chicken house can also be powered from an electrical outlet<sup>8</sup>. A simple block diagram of the chicken farm unit and a picture of the final prototype are shown in Figure 1 and Figure 2, respectively. The Automated Egg Conveyor and Separator is an automated system that is able to transport the eggs from the nest to the separator unit with no human contact. The design of this system involves using relay switches to control the conveyor belt and separation of the eggs based on the height. A simple block diagram of the egg conveyor and separator unit of the final prototype is shown in Figure 3.

This paper is divided as follows: Part I describes the software programming for the automated chicken farm unit; Part II describes the relays used as switches for the chicken farm unit; Part III describes the various units inside the chicken house; Part IV describes the solar power and tracker unit for the chicken farm unit; Part V describes the egg conveyor unit; Part VI describes the egg separator unit and Part VII discusses the relay circuits used for operating the egg conveyor and separator units.

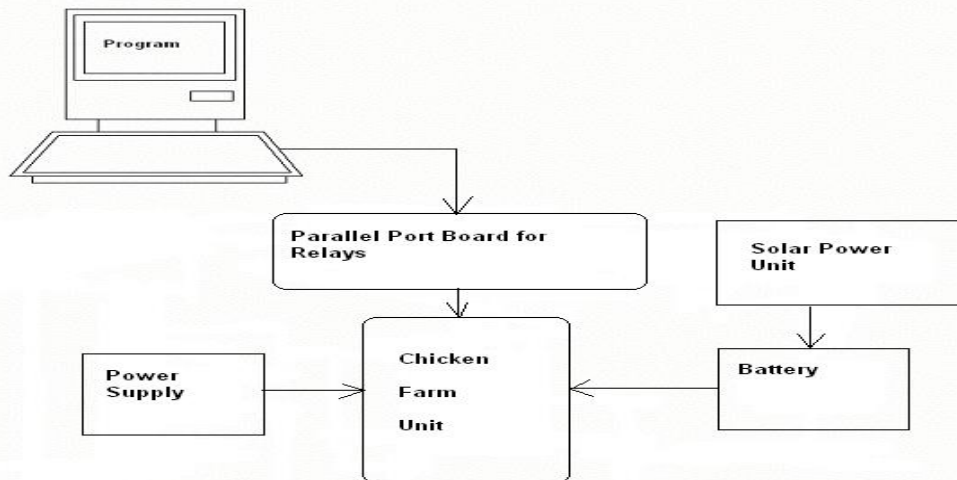

Figure 1. Simple Connection Diagram of Fully Automated Chicken Farm Unit

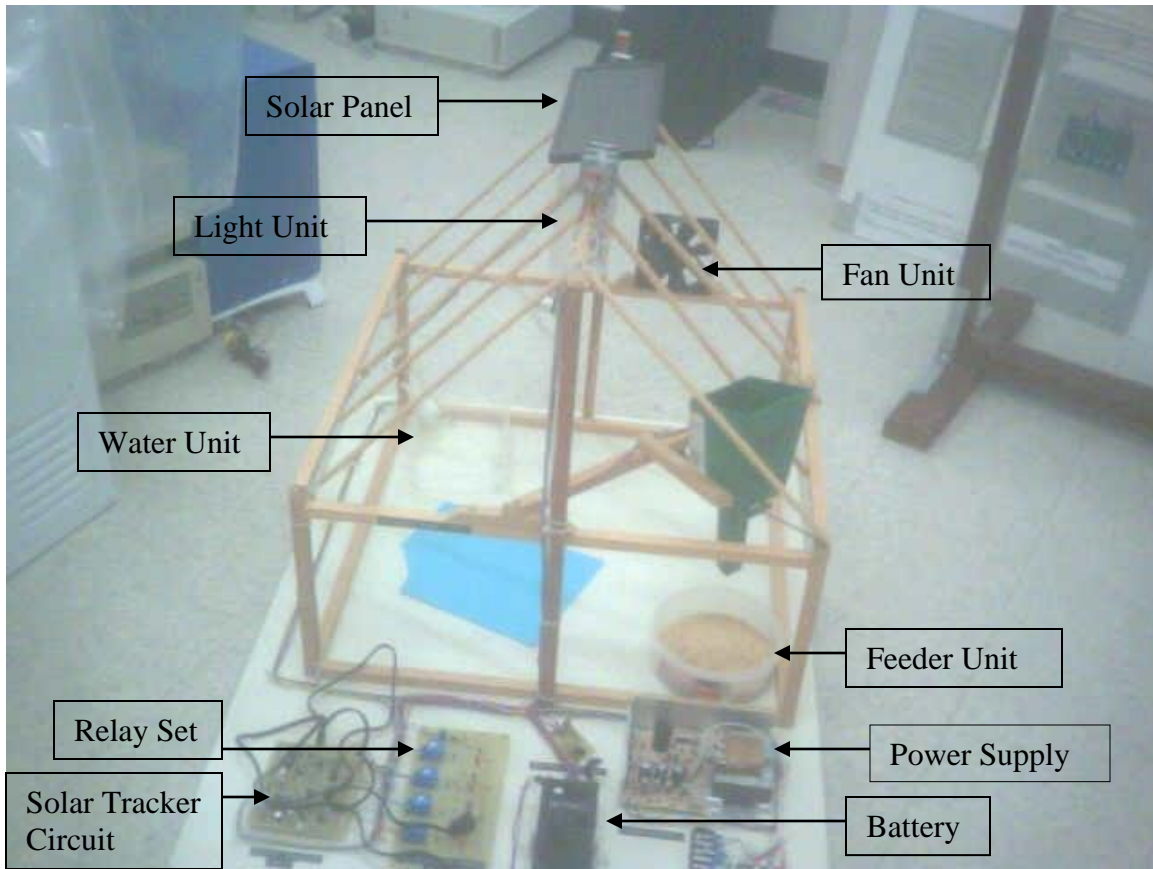

Figure 2. A Fully Automated Prototype Chicken Farm Unit

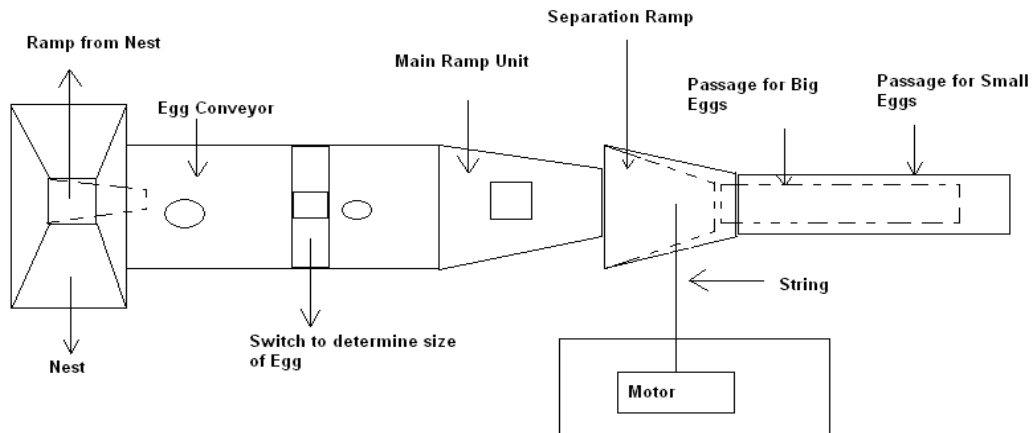

Figure 3. Simple Diagram of Automated Egg Conveyor and Separator Unit

## Part I – Software Program in C Language

The software program for the chicken farm unit is divided into three codes. The operator of the chicken house sets the required conditions for each program.

1. **Relay.Exe:** This program uses 'int main (int argc, char \*argv[])' command to read the argument in the DOS prompt. This program converts a two digit hex number inputted by the operator into binary number which activates the corresponding relays to operate. The syntax of the command to operate the program from DOS prompt is shown below:

Syntax: RELAY <hex byte>

Since <hex byte> is a two digit number thus, it can accommodate eight relays but it is used for only four relays in this project. A flow chart for the Relay.Exe program is shown in Figure 4.

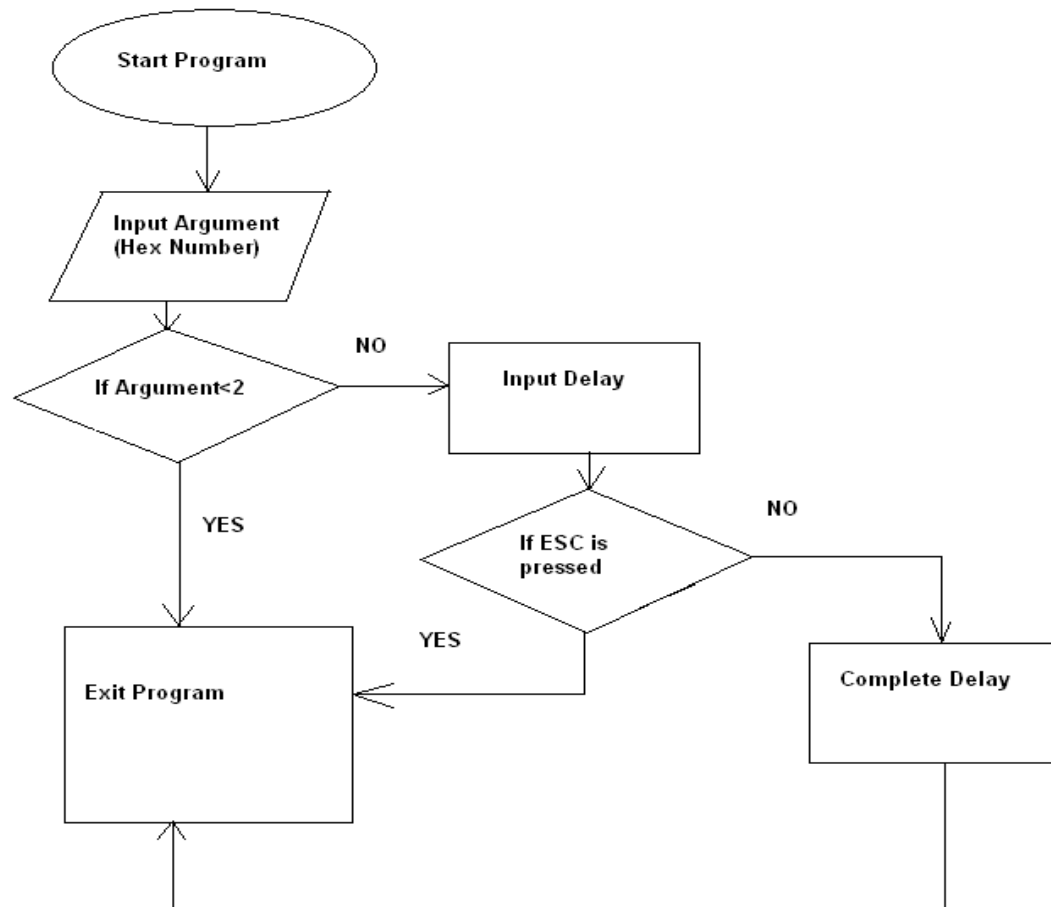

Figure 4. Flowchart for Relay.Exe

2. **Delay.Exe:** This program uses 'int main (int argc, char \*argv[])' command to read the argument in the DOS prompt. This program is used to time the individual units to shut off in case of a failed sensor to avoid damage to the unit or the

chicken house. It produces a delay loop for the given amount of seconds specified in the DOS prompt. The maximum number of seconds allowed is 32,767. The syntax of the command to operate the program from DOS prompt is shown below:

Syntax: DELAY<seconds>

The program waits for the number of <seconds> before exiting. During operation, the remaining number of seconds is displayed. This program can be terminated anytime by pressing the 'ESCAPE' key if the operator wants the program to be exited immediately. A flow chart for the program is shown in Figure 5.

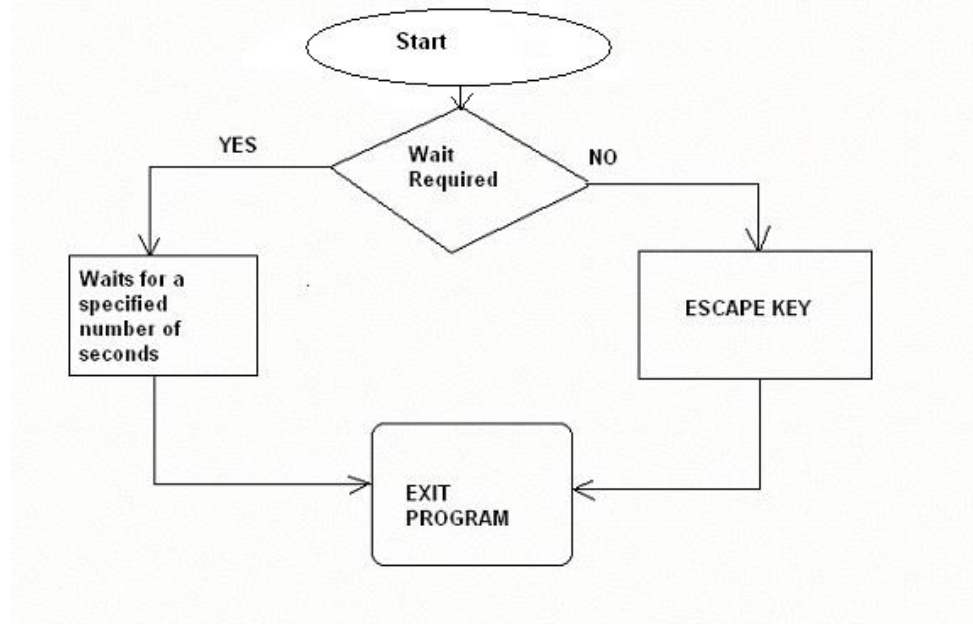

Figure 5. Flowchart Diagram for Delay.Exe

3. **Waitfor.Exe**: This program uses 'int main (int argc, char \*argv[])' command to read the argument in DOS prompt. This program uses a 24 hour clock to specify the time. This program keeps the activated relay circuit running till the clock reaches the specified time written in the DOS prompt. The syntax of the command to operate the program from the DOS prompt is shown below:

Syntax: Waitfor<hh:mm>

The program waits until the specified time <hh:mm> (hours: minutes) is reached before exiting. During operation, the current time in HH:MM:SS is displayed and updated every second. The program can be terminated prematurely by the operator by pressing the 'ESCAPE' key. A flow chart for the program is shown in Figure 6.

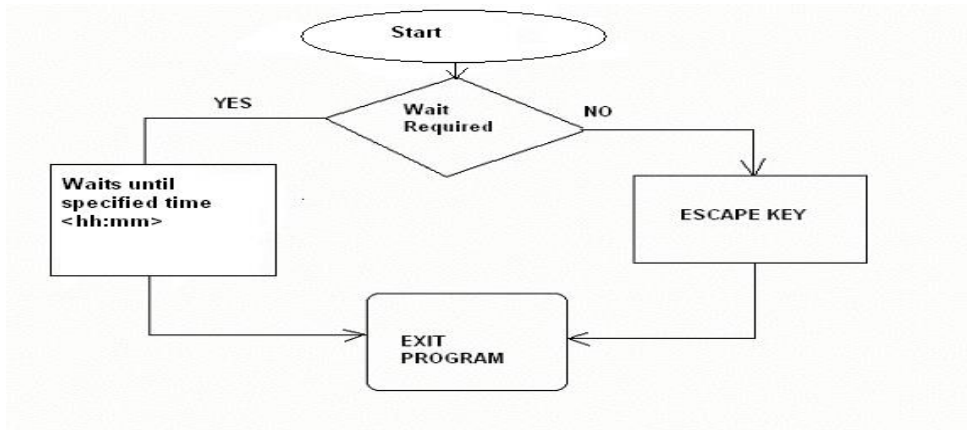

Figure 6. Flowchart Diagram of WaitFor.Exe

## Part II – Relays

The relay circuit for this project uses four BC547 transistors and four relays. The BC547 transistor works as a switch in this circuit operating in cutoff and saturation mode. The circuit is normally within saturation, that is, closed switch. To keep the circuit within saturation, the base current ( $I_B$ ) should be significantly greater than  $I_B$  (min). The values of the resistors are chosen such that the circuit is normally within saturation mode. The function of the relays in this project is to operate as switches to control the operations of the different units depending on the conditions set by the operator. Figure 7 shows the transistor circuit in saturation. There are four sets of relays in the project design. The transistor circuit connected to the set of the four relay circuits is shown in Figure 8.

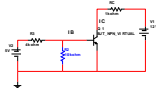

Figure 7. Transistor circuit in the saturation mode

$$I_B(\text{min}) = 5.72 * 10^{-15} \text{ A (According to data sheet)}$$

$$R_{TH} = 4\text{K}\Omega || 10\text{K}\Omega = 2.857\text{K}\Omega$$

$$V_{TH} = 3.57\text{V}$$

$$I_B = V_{TH}/R_{TH} = 1.25\text{mA} > I_B(\text{min})$$

$$I_C(\text{sat}) = V_{CC}/R_C = 12\text{mA}$$

The transistor circuit provides enough current to activate the relay. In saturation,  $I_C(\text{sat})$  is large enough to close the relay.

When the circuit is in cutoff,  $V_{CE}=V_{CC}=0\text{V}$ , and since there is no collector current ( $I_C$ ), the circuit is considered open, and the relay does not operate.

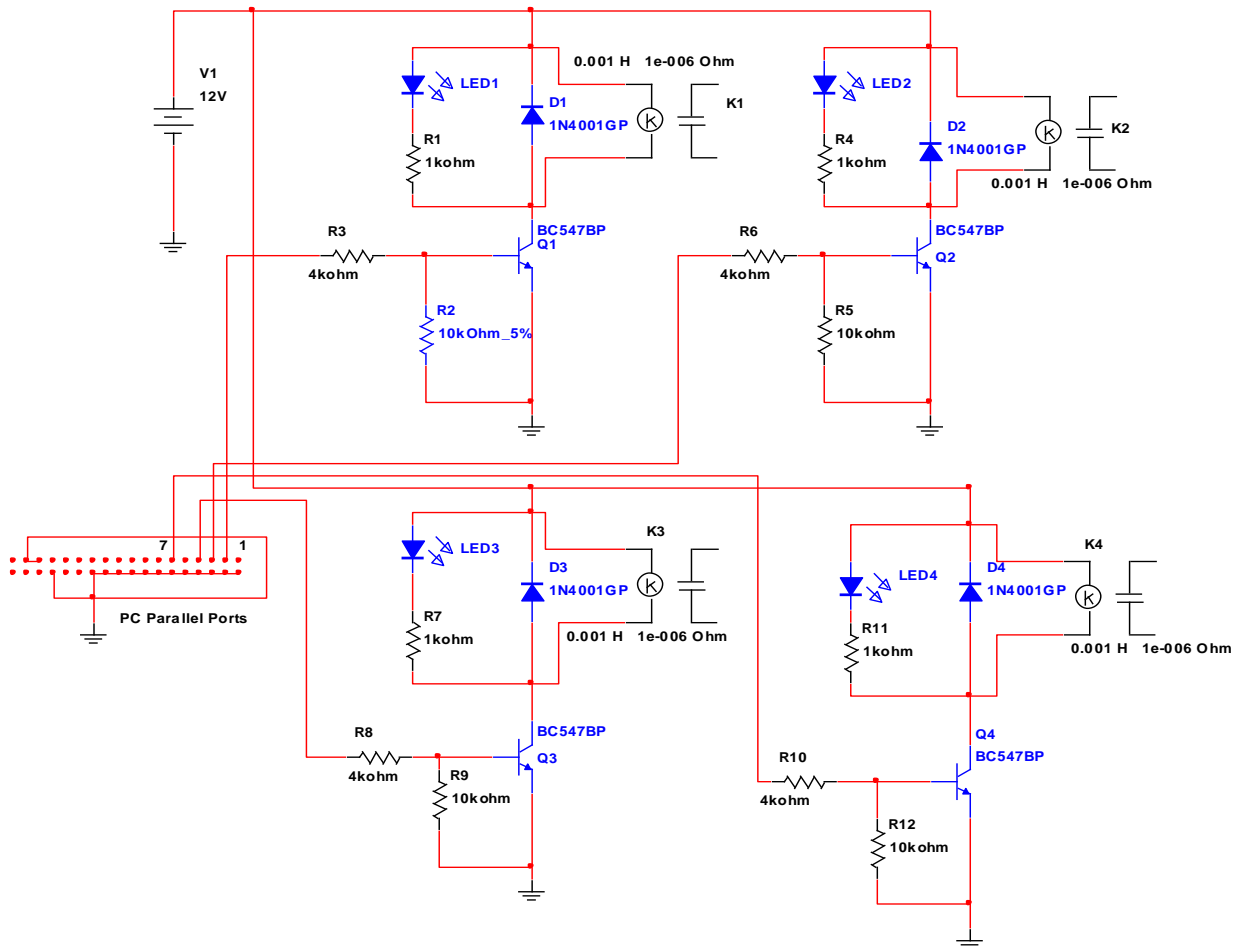

Figure 8. Diagram of Entire Transistor and Relay Circuit

### Part III – Chicken House

The prototype of the chicken house is designed on a wooden table top with size of 50”X37” with height of 18”. The chicken farm unit is made of four automated units. They are:

- a. **Light Unit:** The light is produced from a 120V AC white bulb. The light is controlled by one of the relays. The relay turns the light bulb on and off using a sensor to detect when the chicken house becomes dark.
- b. **Food Supply Unit:** The food unit was designed using a plastic bucket whose lower part is shaped like a funnel. The food plate is placed directly under the plastic bucket. At the bottom of the bucket is a gate which is controlled by one of the relays. The gate opens when the relay switch is on and food comes out to the food plate. When the relay switch is off, the gate is closed. The setting of the relay for the food unit is done by the operator.
- c. **Water Supply Unit:** The water unit has a water tank and bucket to collect water. The unit is controlled by one of the relays. The tank has a valve that is connected to the relay. When the relay switch is on, the valve at the bottom of the water tank opens and water pours into the bucket. When the bucket is filled, the water control switch cuts off and closes the valve.
- d. **Fan Unit:** The chicken farm unit has a fan unit that is controlled by one of the relays. The relay has been set to turn on and off the fan depending the temperature setting through the program by the operator.

### Part IV – Solar Power and Tracker Unit

The solar power unit is the power source for the chicken farm unit. The solar cells extract solar energy from the sun and convert it to electrical energy for use in the chicken house. This unit contains a solar tracker unit which tracks the sun to obtain maximum energy transfer from the sun. The Solar Panel, Stepper Motor, and Stepper Motor Controller were commercially made but were modified to suit the design. The solar tracker unit was designed. The solar tracker is a single axis unit and rotates either east or west depending on the direction of the sun. The solar tracker contains seven major functional blocks to control the system. The functional blocks are:

- a. **Photocell Bridge:** The photocell bridge contains two photocells that are connected in Wheatstone bridge configuration. The function of the photocell bridge is to create a differential voltage if an unequal amount of light is striking one of the photocells. The bridge should be balanced to output 0V when both cells are exposed to equal amount of light. The output of the photocell bridge is fed into an instrumentation amplifier.
- b. **Instrumentation Amplifier:** The instrumentation amplifier amplifies the signal from the photocell bridge. The output of the instrumentation amplifier is fed to a window comparator and to the direction control pin of the stepper motor controller.
- c. **Window Comparator:** The window comparator stops the motor whenever there is an equal amount of light is striking the photocell bridge. The output of the



- window comparator is fed to the relay control logic to control the condition of the motor.
- d. **Relay Control Logic:** The relay control logic controls the clock signal to the stepper motor controller. In its normal state, the relay prevents the clock signal from reaching the stepper motor controller, thereby, preventing the motor from rotating. However, if an uneven amount of light is striking any of the photocells, the relay is energized and the clock signal activates the stepper motor controller.
  - e. **Clock:** The clock consists of a 555 timer in an astable configuration. The clock controls the speed the motor.
  - f. **Stepper Motor Controller:** The stepper motor controller used for this solar tracker unit is the Motorola SAA1042 Stepper Motor Controller. The Motorola SAA1042 Stepper Motor Controller is used for operating devices below 12V. It is used to control the stepper motor. The clock signal is applied to Pin 7 to control the speed of the motor. Pin 8 determines the step size of the motor. This circuit uses half size increments. Pin 10 is used to control the rotational direction of the stepper motor depending on the output from the instrumentation amplifier. The motor rotates clockwise if the output is positive and counter-clockwise if the output is negative. The chip is directly interfaced to the stepper motor.
  - g. **Stepper Motor:** The stepper motor rotates clockwise or counter-clockwise depending on the output of the stepper motor controller. The stepper motor drives the solar platform that contains the photocell bridge thereby allowing the system to track the sun.

### **Battery Charger**

The battery charger charges the lead-acid battery and turns off at full charge. The type of battery used for this kind of circuit is deep-cycle battery. When the battery hits full charge, and LED light comes on to indicate full charge status. A simple connection block diagram of each functional unit is shown in Figure 9.

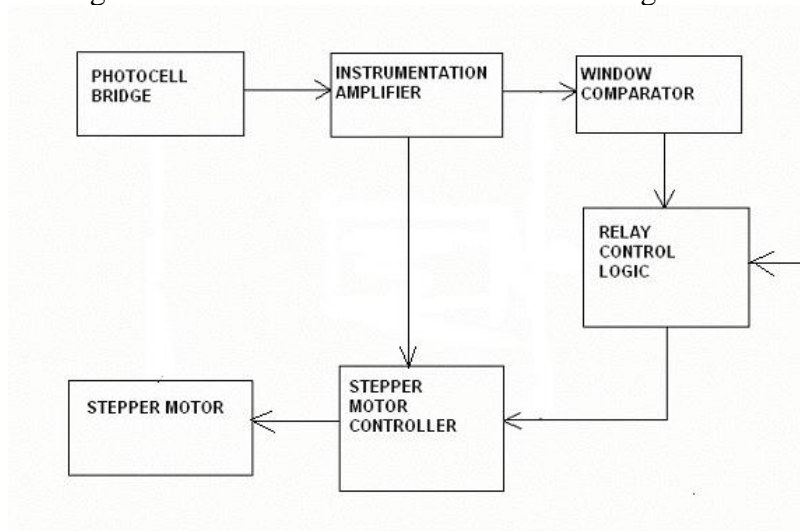

Figure 9. Simple Block Diagram of Solar Tracker

## Part V – The Egg Conveyor Unit

The Egg Conveyor Unit is separated into three parts. It is controlled by one of the relay circuits.

1. **Nest Unit**: The nest was built from a carton box. The nest has a slightly inclined floor with a centered hole which allows the egg to roll out to the conveyor through a ramp attached underneath the nest. The nest ramp contains a relay switch to start the conveyor when an egg comes through.
2. **Conveyor Unit**: The main conveyor is used to transport the eggs from the nest to the separator unit. The conveyor also has a switch to determine the passage the egg follows based on the height. The movement of the conveyor is controlled by a relay switch which allows it to stop rolling when the egg gets to the end. The conveyor was donated by the construction department and some modifications were made to it to fit our application.
3. **Ramp Unit**: The ramp unit is used for transporting the eggs from the conveyor to the separation ramp. It contains the relay switch to turn off the conveyor when the egg drops on it. The ramp was made from Styrofoam.

## Part VI – The Egg Separator Unit

The Egg Separator Unit consists of two parts. It is controlled by another relay circuit. The main conveyor is used to transport the eggs from the nest to the separator unit. The conveyor also has a switch to determine the passage the egg follows based on the height. The movement of the conveyor is controlled by a relay switch which allows it to stop rolling when the egg gets to the end. The conveyor was donated by the construction department and some modifications were made to it to fit our application.

1. **Separation Unit**: This ramp is responsible for separating the eggs based on their height. If the egg is small, the ramp lays flat and transports the egg to one of the passages. If the egg is big, the ramp inclines to another passage for the egg to pass. The ramp returns to its initial position after operation. The movement of the ramp is controlled by one of the relay switches. The ramp was made from Styrofoam.
2. **Passage**: The two passages are made of carton. They receive the egg from the separation ramp unit and allow the egg to roll to the end. At the end of each passage is a blockade to prevent the eggs from falling out of the passage.

## Part VII – Relay Circuits

There are two identical relay circuits used for this project in the egg conveyor and separator unit. The drop of an egg from the nest turns ON the conveyor by switching on the press button PB1 which plays the role of first detector of the egg's passage. The instantaneous closing on the switch BP1 produces an excitation through the coil of the first relay S. This excitation causes a simultaneous change of state of the normally open switches S1 and S2 related to relay S. S1 and S2 therefore close up; the closing of S2

which is on the power line of the conveyor motor sends power to the motor and set it ON, while the closing of S1 which is on parallel to the press button BP1 helps auto-maintaining the excitation of the first relay by keeping the power supply closed. When the egg reaches the end of the conveyor, there is another press button there playing the role of an end-of-course detector. When the egg hits that switch BP2, a 12 V power is sent to K the second relay, its excitation produces the opening of its related normally closed switch K1. K1 being on the main power line supplying voltage to the first is then instantaneously open. This opening cut off the power to the relay S, the result is a reverse change of state of S1 and S2, and both switches go back to their normally open state. The conveyor motor stops since the auto-maintenance of the power supply line is lost. The system is now back to it initial condition awaiting next egg passage.

The same circuit is duplicated and used for the separation of large egg from small ones. In that case the first Switch PB1 (detector) senses the height of the big egg and turns on a motor that inclines the separation ramp and allows passage for the large eggs. When the large egg reaches that destination, it hits another PB2 switch to off the motor and allow a mechanism to bring the spring-board back to its initial position. If the egg is small, the height is not detected therefore nothing happens, and the small egg follows the straight passage. The circuit diagram for one of the relays is shown in Figure 10.

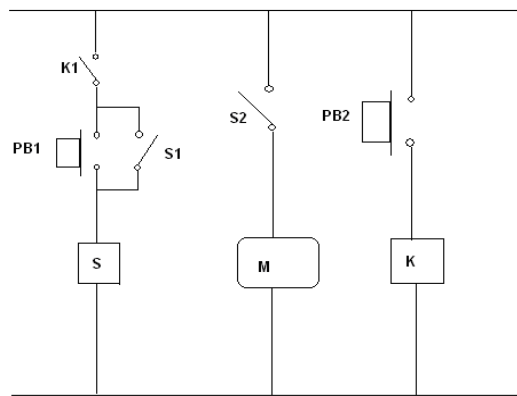

Figure 10. Circuit Diagram of Relay Switch

## Conclusion

This project has been successful in combining different automated units to work together in a single chicken farm unit. The different units were controlled by the relay ports. The DOS-based program written for the relays ports worked as following: Relay.Exe output a hex byte to the designated parallel port allowing the relays at that port to operate, Delay.Exe waited for a defined number of seconds before deactivating the relay, and WaitFor.Exe kept the relays running until the time specified. The relays operated as

switches to turn on or off the unit connected to that particular relay port. The solar power unit supplied electricity to the chicken farm unit while charging the lead-acid battery. The solar tracker unit allowed the solar panels to track the sun clockwise or counterclockwise. This project has not been tested with a chicken as a result of the University Policy. The Automated Egg Conveyor and Separator Unit was successfully completed and operated as designed. The eggs were transported automatically from the nest to different passages depending on their height. The separator ramp inclined to another passage for the large eggs and remained flat for the small eggs. Most of the materials were donated by the Construction department, Electronics Engineering Technology department and by team members. The project was very low cost and cost about \$450. The entire unit was tested using boiled chicken eggs to prevent the egg from spilling on the project during testing. Some problems were encountered during the design of this project. One of such problems was encountered for the chicken farm unit was after the battery was on full charge. The current would change direction and flow back to the solar circuit. The solution to that problem was to use a diode to protect the solar circuit. Another problem encountered was in the design of the solar tracker circuit. There were several stages of instrumentation amplifiers used to amplify the low signals to obtain good input to the window comparator and direction control pin of the stepper motor controller. For the egg conveyor and separator unit, one of the problems encountered was trying to interface the scale with the project. Our initial proposal was to use the weight from the scale as the criteria for separation. Since using the weight of the eggs was a problem, we decided to use the height as a factor for separation. Another problem encountered was in our initial effort of trying to build a conveyor for the project. The rods used in the middle had little friction with the conveyor belt; therefore, the belt was not able to rotate while we tested it. The group decided to use an already built conveyor that was donated and modified it to fit the application.

## References

1. "Automated Systems in Farming" [http://www.school-resources.co.uk/automated\\_systems\\_In\\_Farming.htm](http://www.school-resources.co.uk/automated_systems_In_Farming.htm)
2. BC Egg Producers, "Breaking Plant" <http://www.bcegg.com/aboutbreakers.htm>
3. Applegate, "Egg Cleaning, Sorting, and Grading Machines" <http://www.applegate.co.uk/products/psc/10242.htm>
4. Empire Kosher Industry, Inc., "How Empire Poultry Grow" <http://www.empirekosher.com/?contentpage=pages/chicken.html>
5. Murray McMurray Hatchery, "Automatic Waterers" [http://www.mcmurrayhatchery.com/category/automatic\\_waterers.html](http://www.mcmurrayhatchery.com/category/automatic_waterers.html)
6. Roland Piquepaille, "Chicken Catching Goes High Tech" June 2003, <http://www.primidi.com/2003/06/05.html>
7. "Poultry – Background of Poultry Production in US" <http://www.danpatch.ecn.purdue.edu/~epados/ag101/poultry/pback.htm>
8. Ramakant A. Gayakwad, 2000, *Op-Amps and Linear Integrated Circuits*, 4<sup>th</sup> Edition, Prentice – Hall, Inc.
9. Thomas L. Floyd, 2002, *Electronic Devices*, 6<sup>th</sup> Edition, Prentice – Hall, Inc.
10. William Kleitz, 2002, *Digital Electronics*, 6<sup>th</sup> Edition, Prentice – Hall, Inc.
11. David Rowe, "Dual Axis Stepper Motor Controller" <http://www.atmsite.org/contrib/Rowe/dastep/dastep.html>

**Titilope Z. Alagun**

Ms. Titilope Alagun is a M.S. candidate in Electrical Engineering at the University of Maryland. She received her B.S. in Electronics Engineering Technology at Texas Southern University. Her research interests are control theory and systems. Ms. Titilope Alagun is a member of IEEE and NSBE.

**Dr. Shahryar Darayan**

Dr. Darayan received his Ph.D. in Electrical Engineering from University of Houston in 1993. He is currently a professor and the program coordinator of Electronics Engineering Technology at Texas Southern University. His research area applies to electromagnetic and instrumentation, computer hardware and software design, and numerical methods.