

2018 BEST OVERALL PIC PAPER, Best PIC III Paper: Engineering Design Graphics Division: Case Study of a Blind Student Learning Engineering Graphics

Dr. Steven C. Zemke, Whitworth University

Steven Zemke, Ph.D., has been involved in engineering design and teamwork for 40 years as a professional engineer, university professor, and researcher. He is a Professor of Engineering and Physics at Whitworth University in Spokane, Wash., and teaches physics and engineering courses. His current research is in how students learn engineering with a focus on creating more effective pedagogies. Prior to teaching, Dr. Zemke was a professional product designer for 20 years with an emphasis on mechanical packaging of microwave circuitry.



Case Study of a Blind Student Learning Engineering Graphics

Dr. Steven C. Zemke, Whitworth University

Steven Zemke, Ph.D., has been involved in engineering design and teamwork for 40 years as a professional engineer, university professor, and researcher. He is a Professor of Engineering and Physics at Whitworth University in Spokane, Wash., and teaches physics and engineering courses. His current research is in how students learn engineering with a focus on creating more effective pedagogies. Prior to teaching, Dr. Zemke was a professional product designer for 20 years with an emphasis on mechanical packaging of microwave circuitry.

Case Study of a Blind Student Learning Engineering Graphics

Introduction

The visual communication of ideas is fundamental to most engineering endeavors. Engineering ideas, intent, requirements, and details are typically imbedded in standardized visual documents. Documents of these sorts include 3D CAD models, 2D orthographic drawings, perspective views, graphs, and figures. These documents not only communicate, but also enable engineering thinking. The visual representation of physical ideas allows engineers to manipulate the ideas and meaningfully add increasing levels of detail. Consequently, facility in interpreting these visual communications is a fundamental skill for most engineers.

Typical engineering documents are visual, however simply *seeing* the document is not enough to be able to interpret, reason, and communicate with it. The engineer must be able to internalize the information into a mental map of some sort and appropriately interpret the features.

This case study examines how a blind mechanical engineering student was taught and learned basic concepts of engineering graphical representation. Assistive technologies replaced the ubiquitous computer and paper visual interfaces. The course was intended to enable the student to develop basic mental imagery capability in engineering graphics. These capabilities provided a foundation for engineering thinking for the student and hence met the overall program curricular requirements.

Though this case study is implicitly interesting, it also provides a window into the relationship between mental imagery and the visual expression of ideas. This case prompts the following research question:

What perspectives about the non-visual nature of engineering graphics can be gleaned from the experience of a blind student learning graphics?

This case study was conducted in a six-week, two-credit course in engineering graphics. The student and instructor met individually twelve times for two-hour sessions. All course materials and homework were retained as data. This study chronicles the learning of the student and highlights abilities the student mastered as well as difficulties that were encountered. By the end of the course, the student able to read and sketch both orthographic and isometric views of parts. There was also evidence that the student created and used spatial imagery of parts that included 3D aspects.

Literature review

Graphical communication is a fundamental part of engineering. Correspondingly, spatial reasoning ability is a predictor of success in engineering school. The ability to mentally rotate 3D objects seems especially important [1]. Students' abilities in these areas can be increased through instruction focused on using perception and mental imagery in 3D representation [2]. Effective educational strategies that develop spatial skills and contribute to student success are

well-documented [1]. These strategies have been developed for sighted students, but some of the benefits could reasonable also apply to blind students.

There is also significant impetus to develop effective educational pathways for students with disabilities, such as blindness, into STEM. The ubiquity of important graphical information, typically not available in blind accessible formats, is a significant disadvantage [3], [4]. This difficulty has prompted collaborations between such groups as the National Aeronautics and Space Administration (NASA) and the National Federation of the Blind's (NFB) National Center for Blind Youth in Science (NCBYS) to promote opportunities for blind youth in science [3]. This interest in providing pathways for the blind has led to an exploration of assistive technologies. Tactile graphic images can serve the same function to the blind that pictures can to the sighted [5]. However, the *readable* resolution of tactile images is much lower than visual images and also cannot take advantage of multiple colors [5].

There is also legal impetus for universities to develop pathways for blind students. Section 504 of the 1973 Rehabilitation Act prohibits discrimination against people with disabilities within institutions that receive federal funds [6]. The Americans with Disabilities Act (ADA) of 1990 further prohibits discrimination against people with disabilities [6]. These two Acts require post-secondary institutions to provide services (such as brailled text or adapted computer terminals for the blind) unless these services would fundamentally alter the program or generate undue financial burdens [7].

The student in this case was enrolled in an ABET accredited engineering program. To complete the program the student needed to complete all required courses or *reasonable* substitutes. Learning to use a 3D modeler was a required course, and learning engineering graphics using assistive technologies was deemed to be a reasonable substitute.

Visualization and mental imagery

Engineering graphics courses commonly use the term *visualization* to describe being able to mentally interpret 3D graphical information. Since this specific case involved a totally blind student, the term visualization seems limited. In cognitive psychology, the term *mental imagery* is used in a similar way. Visual mental imagery is defined as, "...the capacity of envisaging objects and scenes in their absence" [8]. Further definitions of mental imagery are: "the mental invention or recreation of an experience that at least in some respects resembles the experience of actually perceiving an object..." [9 as cited in 8] and "a cognitive process that makes the figural aspects of previously seen objects...temporarily available to the mind." [10 as cited in 4]. Furthermore, mental imagery is an active process in problem solving [8]. Hence mental imagery is engaged for both blind and sighted people when interpreting engineering graphics.

Mental imagery is cognitively part of visuospatial working memory, used for reasoning [11], and not merely an internalization of the visual percept (actual sight). Mental imagery differs from vision in that vision is a bottoms-up process, where visual stimuli are processed into sight, versus a tops-down process where knowledge is processed into imagery [8]. Some visual processes do not occur in mental imagery [12], but mental imagery does seem to depend on areas of the brain related to higher levels of integration in typical visual processing [13].

Since this study examines how a blind student learned engineering graphics, understanding differences in the mental imagery between blind and sighted people could inform it. Studies of totally congenitally blind people have made it possible to understand the contribution of visual experience for imagery processes [14]. Blind people appear to have the same visuospatial processes as sighted people, but with some capacity limitations and difficulty with some three-dimensional tasks [14], [15]. These differences seem to have a developmental component to them.

Some studies have shown profound spatial deficits in early-blind (those who lose sight at a young childhood age) participants, but other studies have not [16]. One study showed that of blind 11 year-old children, those who had sight when younger demonstrated spatial reasoning but the congenitally blind did not [17]. Another study showed that late-blind subjects used a visuospatial strategy to solve a two-dimensional problem presented verbally, but the early-blind subjects used a different strategy [18].

From a sighted perspective, one study found that blindfolded architects could enact a conceptual design using spatial imagery alone [19]. It was cognitively more wearing, presumably because sketching allows the architect to externalize working memory.

In summary, mental imagery is processed in visuospatial working memory in both sighted and blind people. It is a tops-down process where information is processed to form an image. Congenital or early blindness may impede the development of spatial abilities and related problem solving strategies. A study with sighted people has shown that spatial problem-solving is possible, but more difficult, without the use of sight and sketches.

For the purpose of this case, mental imagery is defined as cognitive processes that enable the understanding and manipulation of 3D spatial information.

Methods, study context, and data

Case studies examine bounded, integrated systems [20]. In this study, the case was bounded by the single student, the instructor, and the context of the class. Qualitative research employs a wide variety of methods, which frequently generate a rich description [21]. Since this study was exploratory, a descriptive approach was most appropriate [22]. The description in this study takes the form of describing the student's path while learning graphics. The description combines text and photographic examples of student work and corresponding curricular materials.

This study was conducted in a two-credit class in a moderately sized undergraduate engineering school within a private university. The course met the curricular goals of the Mechanical Engineering program by teaching the basic standards of graphical communication. These skills were deemed sufficient to understand how graphics are used and constructed so that the student upon graduation could successfully enter the workforce. Facility on a 3D CAD system with a visual interface was not a goal of the course, nor was facility in reading detailed 2D drawings.

The six-week course involved twelve two-hour one-on-one tutoring sessions between the student and instructor. Each session would begin with a problem-by-problem review of homework from the previous session. These reviews gave the student immediate feedback on work, kept the instructor aware of the student's progress, and provided a venue for diagnosing misconceptions

that may be developing in the student. Following the homework review, the instructor presented new material, worked on problems jointly with the student, and made sure the homework objectives were clear to the student. The student's progress was assessed with a mid-term and final, which tested for the same skills developed in the homework.

During each session, the instructor kept notes on a laptop to track the student's progress and potential difficulties. These notes were indexed to the in-class materials and the reviewed homework, which were both retained as study data. The student's homework and exams were also retained as data.

The student

The student was born with minimal eyesight, never had the use of both eyes, and became completely blind by early grade school. At the time of the course, she had progressed to junior year status in the Mechanical Engineer program. It was not possible for her to take the standard engineering graphics class because the CAD modeler used a visual interface with high resolution and situationally adaptive icons within the program.

Assistive Technologies

3D printed parts

Parts with a maximum dimension of 3 inches and a minimum feature size of $\frac{1}{4}$ inch were used for practice and homework problems. These provided direct access to geometries for student and instructor discussions. Since these parts could be physically examined and felt (haptic percept), they provided scaffolding for learning. This scaffolding was removed as the student's graphics abilities advanced.

Email voice reader

The student had a text-to-voice reader for email. This capability allowed the student to receive detailed homework instruction and other content. Shorter messages were found to be more helpful. The reader only translates words and characters, but not images.

Braille sketch pad

The braille sketch pad (DRAFTSMAN Tactile Drawing Board, American Printing House for the Blind, Inc.) consists of a frame that holds a thin 8.5 x 11 inch plastic sheet over a urethane rubber drawing area. When a quill is drawn across the plastic sheet, the quill locally stretches the sheet and creates an embossed line, which can be felt and seen. The minimum parallel line spacing is $\frac{1}{4}$ " and it is difficult to differentiate between thick and thin lines. Lines cannot be erased; however, a second plastic sheet can be clamped over a prior sheet and retraced. This method worked well for eliminating construction geometry on complicated drawings. Figure 1 shows a braille sketch pad.

Swell paper

Orthographic and isometric views of parts were printed on paper with embossed lines. The process involves printing a CAD figure onto swell paper (Zychem Ltd.) with a standard laser printer. The paper is then fed through a desk top machine with heating lamps. The black marks on the paper swell when heated. Swell paper is available in 8.5 x 11 and 11 x 17 inch sizes. The embossed lines were swelled to approximately the same height and width as typical braille dots. Thick and thin lines are readily distinguishable, but close features need to be about 0.100" apart to be readily distinguished by touch. Figure 2 shows a close up view on a swelled drawing.



Figure 1: Braille sketch pad.

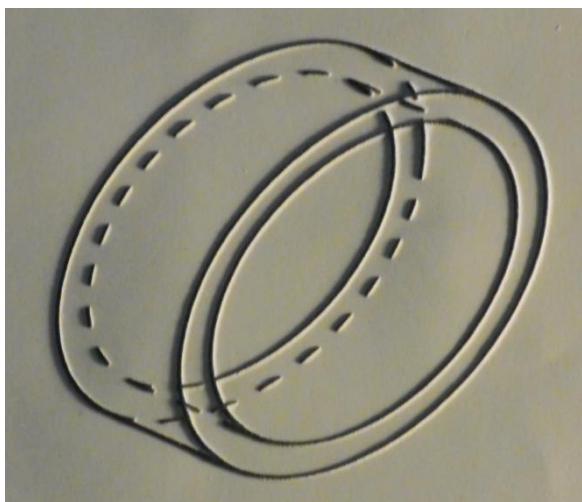

Figure 2: Swelled drawing close up.

Braille printing

The Accommodations Office brailled instructions for exams on standard size and weight braille sheets. The process involved converting a text file to a braille format before printing, which incurred a short amount of turnaround time. Braille can represent only text and standard characters.

Combination of swell paper and braille sketch pad

It was possible to cut a hole in a swell drawing to place over the braille sketch pad. This conveniently allowed *fill-in-the-sketch* assignments to be designed on a CAD system, printed and delivered on swell paper, and completed with a braille sketch. Swelled 11 x 17 drawings allowed missing views to fit comfortably on the 8 x 11 braille pad. Figure 3 shows an assignment of this type.

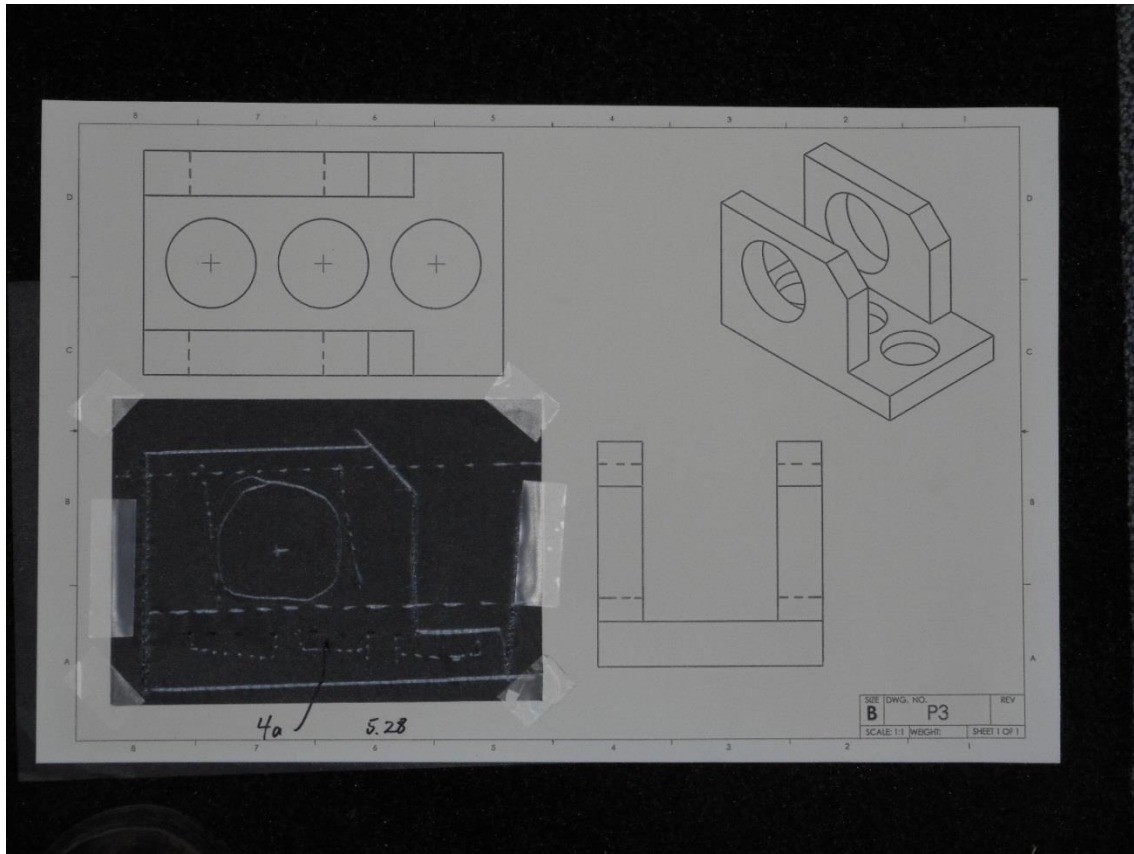

Figure 3: Combined swell paper and braille sketch pad assignment.

Embossed characters on swell paper

Drawings of parts usually include dimensions, which can be embossed on swell paper. However, characters in a 0.200" tall font (about the same size as braille characters) are not easily read with the fingers. Braille dot dimensions are easily within the capability of a CAD system; however, the instructor did not have sufficient preparation time to create an efficient process to place braille dimensions on drawings, and so these were not used.

Class sessions and learning to sketch

The course goal was for the student to learn to communicate using standard conventions of engineering graphics for 3D mechanical parts. This ability would enable the student to communicate ideas in subsequent design classes with peers on teams as well as contribute in some work settings. Learning to follow engineering graphic conventions was the base level outcome. Many of these conventions can be enacted algorithmically, much as a CAD system can automatically generate orthographic projections given geometric information about a part. So, at a deeper level the goal was to learn to generate mental imagery of a part and understand information from that level. Correspondingly, the underlying assumption was that algorithmic abilities and mental imagery abilities are both useful engineering graphic skills.

The course was divided in three broad, but overlapping, sections. In the first section the student learned to create orthographic views of 3D printed parts. Beginning with physical parts is a common scaffolding technique in many graphics courses when first introducing orthographic projections. In the second section, the student learned to sketch orthographic views based on isometric views. In the final section the student learned to sketch isometric views based on orthographic views.

Sketching orthographic views of 3D printed parts

In the first four sessions, the student learned to draw orthographic views of 3D printed parts. The student learned to use solid and dashed lines for visible and hidden features, show views in proper orientation relative to each other, and sketch views to the same scale.

During this time the student encountered difficulties common to many beginning graphics students such as omitting hidden lines, improperly showing a tangent transition from curved surfaces to planes, and attempting to show both dashed and solid lines for coincident features. The student also had initial difficulties with parallel lines tending to taper toward each other. Notably, the student did not mistakenly produce 1st angle projections; all course work was in 3rd angle.

A side by side view of a part and sketch, which required an auxiliary view, is shown in Figure 4. The student created a proper rotation which included foreshortened features as well as true size/true shape features of the angled face. Further angled parts were presented and completed properly by the student.

The part shown in Figure 5 was assigned on the third and fourth days. When an auxiliary view is created for the angled flange, the upper portion of the view contains foreshortened features. Though the student was able to verbally talk the instructor through the part, she could not

complete a view showing these features correctly. Since the instructor deemed this part more advanced than the course objectives, attempts on it were concluded on the fifth day.

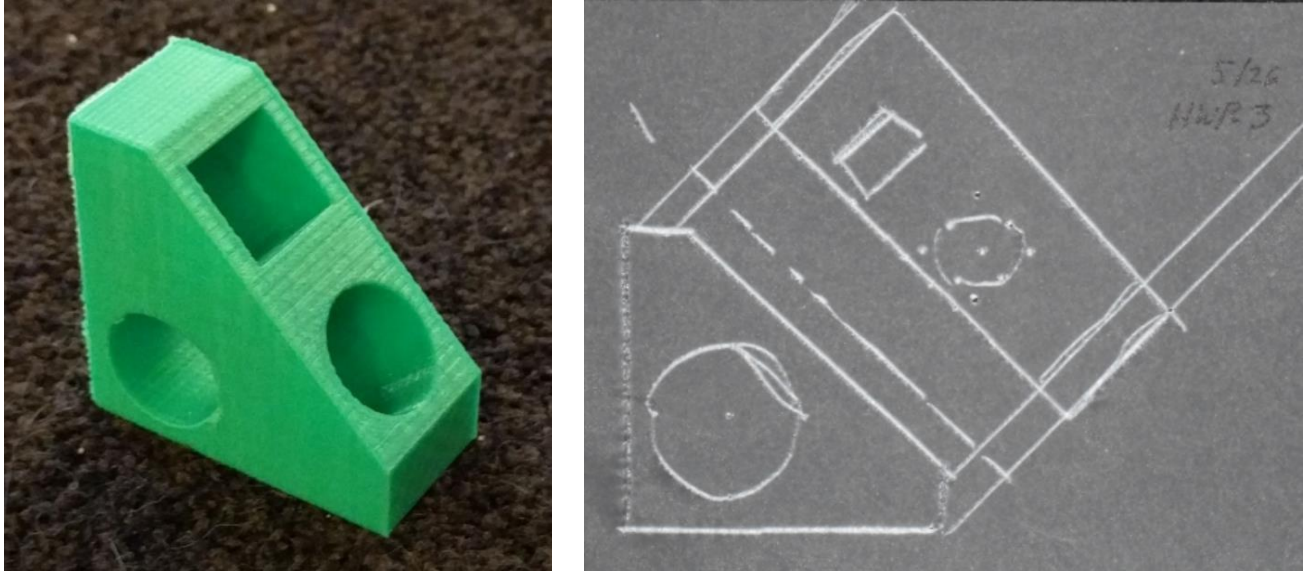

Figure 4: Side-by-side example of part and sketched views.



Figure 5: Part requiring difficult auxiliary view.

During the first few sessions, two things were noted. First the student stated that *feeling-to-use* an item is different than *feeling-to-draw*. Feeling-to-draw requires much more attention to position and sizes of features. Second, the instructor observed that much of the direct instruction was step-by-step algorithms, such as extracting information from one view of a drawing to use in another view. However, the student's verbal descriptions while reviewing parts were holistic, and not merely a sequence of step-by-step descriptions.

Drawing orthographic views without supporting 3D printed parts

The second portion of the course continued to develop ability to create orthographic views, but removed the support of 3D printed parts. The initial exercises required the student to sketch missing orthographic views with the support of the surrounding orthographic views and the support of an isometric view. Following this session, the student was given similar missing orthographic views to sketch, but was not given supporting isometric views. In the final sessions, the student was asked to sketch top, front, and right views of given isometric views.

The transition away from 3D printed parts began in small pieces beginning on the third session with an in-class exercise of rotating a cube. Usually a cube is shown with the central view as a square making the corresponding top and side views squares as well. However, if the central view is drawn at a 45° rotation, then the top and side views show faces of the cube obliquely. This exercise supported learning to make auxiliary views. However, if a central view at 45° rotation is subsequently rotated toward the back, all faces show obliquely in an isometric format. The student readily followed these rotations, and could identify the resulting 2D (flat) shape of the obliquely shown faces. Generating these views of a cube was assigned and readily completed by the student.

The transition away from 3D printed models began in earnest on the fifth session. The student was given a physical part to describe. The student then identified the faces of the part corresponding to the front, top, and right view on an orthographic swell drawing shown in Figure 6. Following this, the student identified the corresponding faces between the orthographic views and an isometric view. Finally, the student identified corresponding faces between two different isometric rotations of the same part. The homework for this lesson asked the student to sketch missing views in orthographic sets of views. Each orthographic set had a supplemental isometric view, which the student described to the instructor in advance of doing the assignment. An example was shown in Figure 4.

In the following session, the student was again assigned to sketch missing orthographic views, but without supporting isometric views. In the final session in this sequence, the student was assigned to sketch top, front, and right views of given isometric views. Throughout these sessions, the student verbally described isometric parts, with a broad range of features, presented in class by the instructor. These verbal descriptions gave the student practice in interpreting isometric views, as well as direct feedback when difficult features were encountered.

During these sessions two things were noted. First, the student was able to verbally describe parts represented in isometric views, as well as sketch corresponding orthographic views. The part descriptions would begin with a description of major features and then progress to a holistic part descriptions. This indicated the student was developing mental imagery of the part. Second,

the student's error rate increased with these exercises indicating that the task of interpreting an isometric is more difficult than understanding a part by feel. This was easily detected in the student's work because erroneous lines on the braille sketch pad cannot be erased.

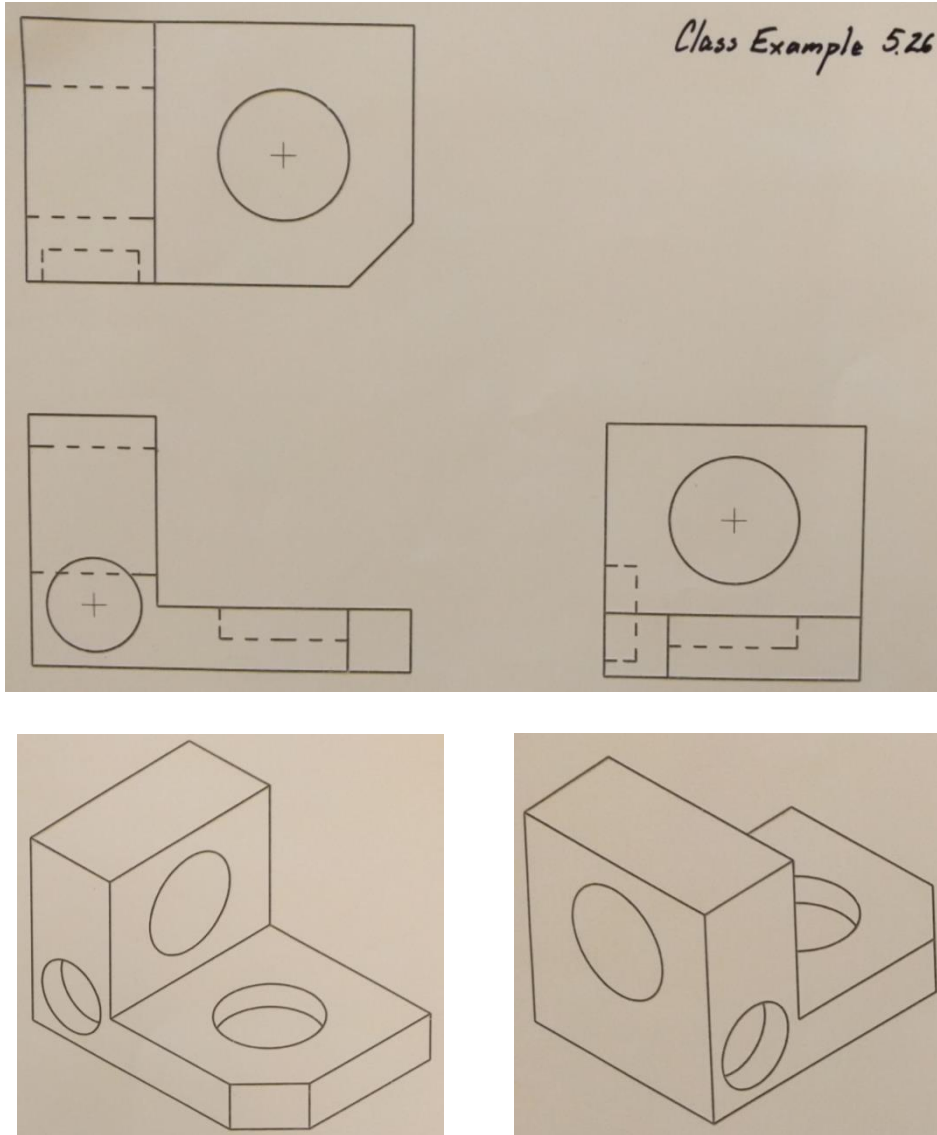

Figure 6: Example swell drawings where student identified isometric faces, on different rotations, corresponding to orthographic views.

Sketching isometric views of parts

For sighted students, isometric views simply appear as simplified representations of what is seen with normal vision. Since the student in this study was early-blind, and also never had use of both eyes, she did not have this visual experience, and most likely would not perceived isometrics as a sighted or late-blind person would. Isometric views were explained as how an

object looks to a sighted person. Physical ray tracing from the student's eyes to points on a physical object were used to explain which features were visible and which were hidden. Earlier exercises had developed the concept of foreshortened lines, which were combined with the aspects of ray tracing to help establish the shape of obliquely shown surfaces.

The instructor introduced the use of a 30/60/90 triangle to help the student sketch isometrics. The student began by sketching an "L" shaped part. Manually creating isometric views usually generates many construction lines, which given the low resolution of the braille pad and the poor distinction between heavy and thin lines, made the views difficult to interpret. The student found that lines on a braille sketch could be felt through an overlying clean sheet and then retraced to eliminate the distractors. Two techniques made this task easier: rotating the tablet so retracing was vertically downward toward the student, and positioning the quill at the start of the line and a finger of the alternate hand at the end of the line so tracing was toward a known destination.

Two things are worth noting here. First, the student remarked that the typical display of x-y-z axes in math classes now made sense; they were simply a perspective view! Second, the student was genuinely enthused by the ability to create isometric views that sighted students could easily interpret visually.

The following figures show examples from the sessions devoted to sketching isometric views. Figure 7 shows features that are tactilely hard to interpret because coincident lines are edges on different planes. In contrast Figure 8 shows a student sketched part with chamfered corners, where the vertical edge of chamfer and the horizontal edge of the mating top surface are collinear in the drawing. When asked to describe the collinear lines, the student replied that, "The chamfer line doesn't *look* up and down, but looks like it is at an angle because of how the rest of the part is." This remarkable comment indicates that the student was understanding the part in a holistic way *and* that the features on the isometric sketch represent edges of it in a coherent fashion.

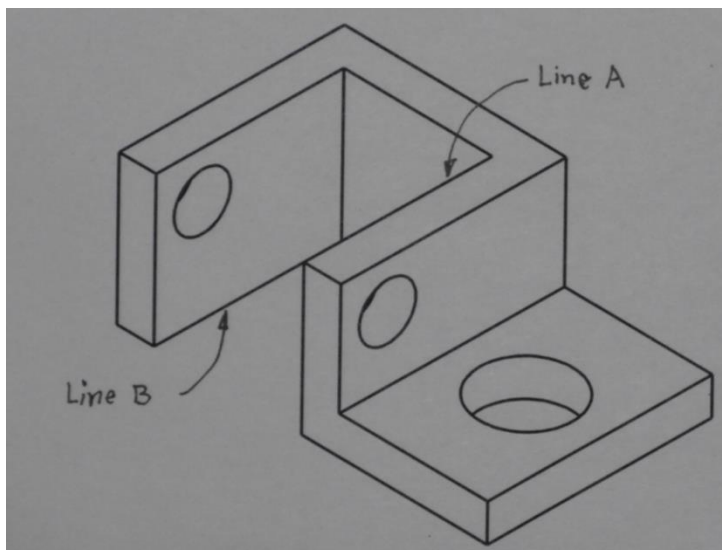

Figure 7: Coincident lines (Line A and Line B) on different planes in an isometric view.

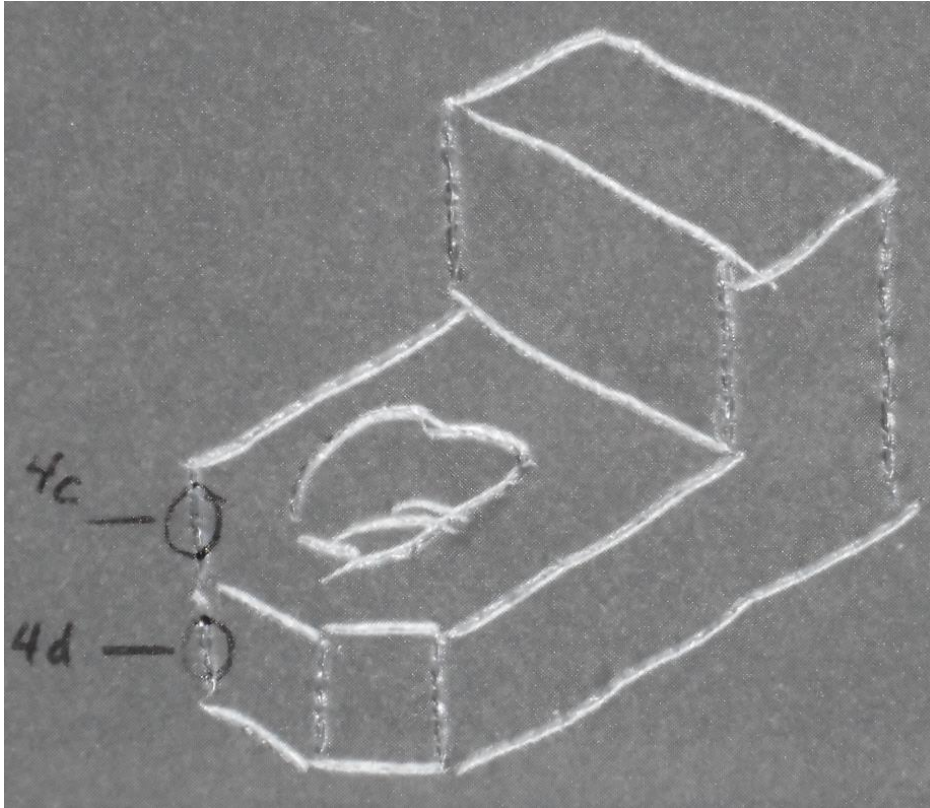

Figure 8: Student sketched chamfered corner where collinear vertical line represents two edges on different planes (indexed 4c and 4d in data).

Figure 9 shows a part with curved surfaces which the student found difficult to sketch. In contrast, Figure 10 shows a very similar part that the student sketched without difficulty.

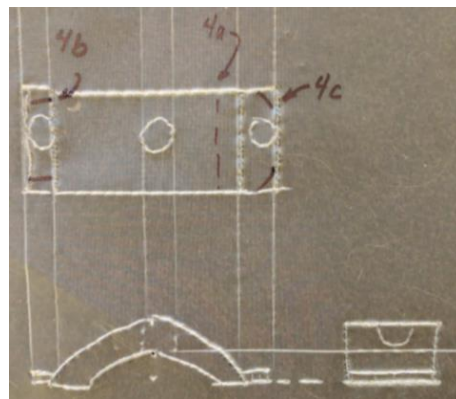
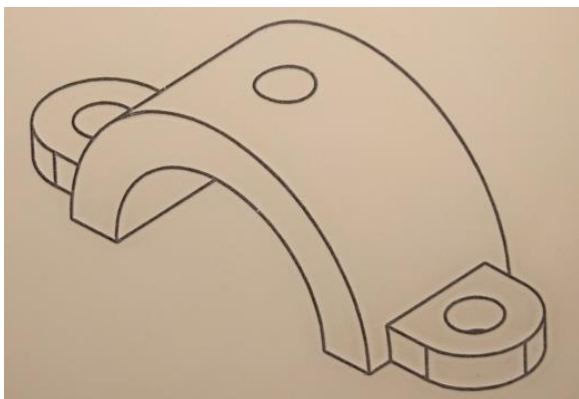

Figure 9: Curved surface part that proved difficult for student to render orthographically.

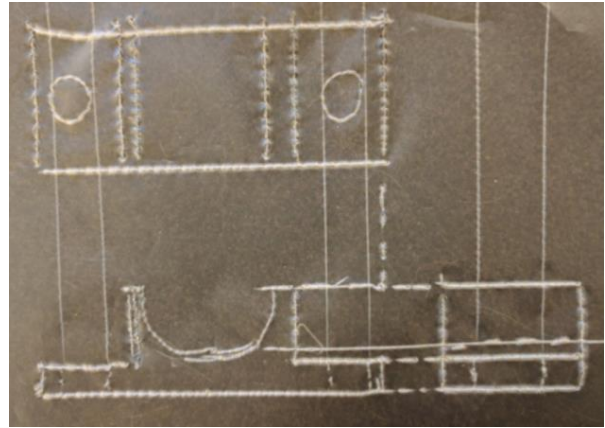
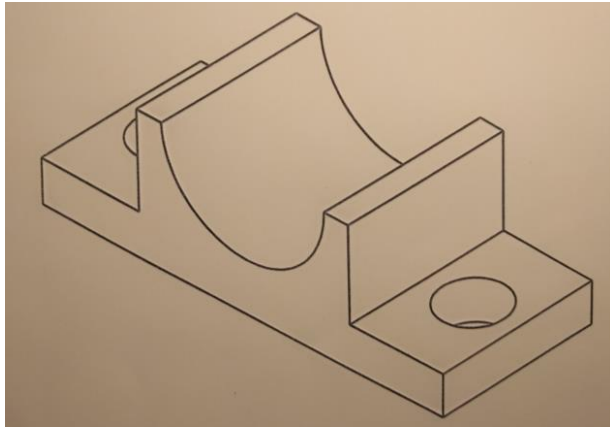

Figure 10: Similar curve surface part that the student sketched easily.

In summary, the student learned to sketch isometric views of parts without the support of 3D printed parts. The isometric views were clear, and visually easy to interpret. The student's verbal descriptions of these parts were holistic and clear.

Discussion

The student learned to sketch parts in orthographic and isometric views. She was also able to pull and process information about parts from views, as well as find missing or incorrect information within views. Clearly, she was using mental imagery to understand these parts. However, what characteristics of her mental imagery are demonstrated or implied by her sketches and comments?

Navigating a part

It is possible, and at times very useful, to process the information in a drawing algorithmically. Though an engineer may conceive of a part in a holistic way, getting the details correct is crucial. At times this work is step-by-step through details and very algorithmic. The student also showed this characteristic when first *reading* a drawing or when systematically reviewing drawing features to find missing or incorrect elements. At a minimum, this implies that the student's mental imagery was sufficient to navigate around a part and inspect specific regions of a part.

From physical part to mental image

The student learned to create orthographic views from physical parts. Physically feeling a part was the source of mental imagery information, which was then cognitively translated into orthographic views. Creating each view would require primarily 2D imagery of the viewed surface with some depth information for other surfaces viewed from that direction. The operation would also require enough imagery to correctly position the view relative to other rotated views. This was also not solely a one-way process from mental imagery into sketching, since there was cross checking from the sketch back to the part.

The student noted that feeling-to-draw was different than feeling-to-use. Specifically, she noted that though an indentation in a remote control seemed in the middle when using it, it was actually far off center when the object was being inspected to be sketched. This indicates that more

attention, or perhaps different attention, is applied when developing a mental image for sketching than for everyday uses.

From partial views to mental image

When the 3D printed parts were replaced with incomplete orthographic views or isometric views, different constraints were placed on mental imagery generation. Arguably, it is a different task to process views of a part into a mental image of the part than process haptic sensory information of the same part. This implies that the student was able to build aspects of a spatial image from 2D information.

Contrasting the student's verbal descriptions with her actions to *read* isometric views also support this inference. Her descriptions were holistic about the part. For example, she would describe a part as "L" shaped, rather than describe the *front surface* as "L" shaped. In contrast, when initially inspecting an isometric view she would move from feature to feature, as if creating a spatial image of the part.

From orthographic views to mental image

The student interpreted the end-to-end collinear vertical line segments noted in Figure 8 as being edges on two different planes. Sighted people would distinguish these features easily because of experience seeing such features. But how did the blind student differentiate them? When asked by the instructor she simply stated, "The chamfer line doesn't *look* up and down, but looks like it is at an angle because of how the rest of the part is." Her response was immediate and appeared to require no effort. This implies that her spatial image included 3D aspects that differentiate between edges formed by intersecting surfaces in different orientations. This imagery is more than solely points in 3D space, but rather features spanning 3D space.

Her spontaneous comments that the standard drawing of an x-y-z axis in math classes now made sense also support the idea that her spatial imagery developed in this course. From prior math courses an x-y-z axis was merely an odd formality; it was just the way it was drawn. The y-axis was just shown as an angled line on the page, but did not take on a full 3D spatial attribute to it. However, when learning to interpret isometric views, she realized the y-axis was not merely an angled line on a page, but was a line in 3D space.

Application of findings to sighted students

One basic goal of most graphics courses is for students to develop facility in spatial imagery. Instructors are rightly concerned that students develop a deeper sense of graphics than solely a manipulation of lines on a page or creating pretty pictures on a computer. This study suggests a possible approach.

The student in this study developed mental imagery of parts without the use of sight. If sighted students were given physical parts to examine while blindfolded and then subsequently asked to sketch them, then their sketches would be based solely on their mental imagery. This sort of exercise would bypass the visual percept, and reliance upon it, and work to develop attention to detail in a mental image.

Weigers, et. al. [23] employed a similar approach to teach students to verbally describe physical parts. In their approach, blindfolded students described physical parts they were handling to a partner who was sketching the part. The blindfold helped focus the student's attention on specific details of the part and clear descriptions of them. Similarly, a blindfold could potentially focus a student's attention on features of the part that would be typically overlooked if seen.

Conclusions

This study supports two conclusions within the limitations of the case:

1. It is possible for a blind person to learn and use the conventions of engineering graphics as applied to orthographic and isometric views. This ability includes both generation and interpretation of these graphics. It should be noted that the student continued to progress throughout the entire course and that her graphic ability at the end was limited only by the length of time in the course; the curriculum did not exceed her abilities with mental imagery.
2. There was evidence that the blind student used mental imagery to navigate parts, identify and correct features in drawings algorithmically, and to understand a part holistically in a 3D sense.

In terms of future study, this case suggests that the use of blindfolded activities may be a reasonable curricular option to explore to help sighted students develop spatial abilities.

Acknowledgements

The author wishes to thank Jason Varnado at the Center for Student Academic Success office at Gonzaga University for his unfailing support in developing curricular materials for the blind student. Without his efforts, the course content would have been diminished. The author also wishes to thank the blind student for her efforts in the course and explaining how parts and swelled drawings were perceived throughout the course.

References

- [1] S. A. Sorby, "Educational research in developing 3-D spatial skills for engineering students," *International Journal of Science Education*, 31-3, pp. 459-480, Feb. 2009.
- [2] C. Potter, and E. Van der Merwe, "Perception, imagery, visualization and engineering graphics," *European journal of engineering education*, 28-1, pp. 117-133, Mar. 2003.
- [3] B. Beck-Winchatz, and M. A. Riccobono. "Advancing participation of blind students in science, technology, engineering, and math," *Advances in Space Research*, 42-11, pp. 1855-1858, Dec. 2008.
- [4] D. Fitzpatrick, "Teaching science subjects to blind students," in *Advanced Learning Technologies, ICALT 2007*, Seventh IEEE International Conference on July 18, 2007, pp. 917-918.
- [5] Gardner, John A. "Tactile graphics: an overview and resource guide," *Information Technology and Disabilities*, 3-4, Oct. 1996.

- [6] A. Mayerson, "The History of the Americans with Disabilities Act, A Movement Perspective," 1992, [Online]. Available: <http://dredf.org/news/publications/the-history-of-the-ada/>. [Accessed June 8, 2017].
- [7] D. Leuchovius, "ADA Q & A: Section 504 & Postsecondary Education," 1994, [Online]. Available: <http://www.pacer.org/publications/adaqa/504.asp>. [Accessed June 8, 2017].
- [8] C. Zaira, M. C. Fastame, T. Vecchi, and C. Cornoldi, "Working memory, imagery and visuo-spatial mechanisms," in *Imagery and Spatial Cognition: Methods, models and cognitive assessment*, T. Vecchi and G. Bottini Eds., Philadelphia: John Benjamins Publishing Company, 2006.
- [9] R. A. Finke, *Principles of mental imagery*. Cambridge, MA: MIT Press, 1989.
- [10] M. Rinck, and M. Denis, "The Metrics of Spatial Distance Traversed During Mental Imagery," *Journal of Experimental Psychology: Learning, Memory and Cognition*, 30-6, pp. 1211-1218, Nov. 2004.
- [11] R. J. Sternberg, *Cognitive Psychology*, 3rd Edition. Belmont, CA: Thomas Wadsworth, 2003.
- [12] D. Chambers, and D. Reisberg, "Can mental images be ambiguous?," *Journal of Experimental Psychology: Human Perception and Performance*, 11, pp. 317-328, Jun. 1985.
- [13] P. Bartolomeo, "The relationship between visual perception and visual mental imagery: a reappraisal of the neuropsychological evidence," *Cortex*, 38-3, pp. 357-378, Dec. 2002.
- [14] C. Cornoldi, A. Cortesi, and D. Preti, "Individual differences in the capacity limitations of visuospatial short-term memory: Research on sighted and totally congenitally blind people," *Memory & Cognition*, 19-5, pp. 459-468, Sep. 1991.
- [15] A. Aleman, L. van Lee, M. H. Mantione, I.G. Verkoijen, E. H de Haan, "Visual imagery without visual experience: evidence from congenitally totally blind people." *Neuroreport*, 12-11, pp. 2601-2604, Aug. 2001.
- [16] C. Thinus-Blanc, and F. Gaunet, "Representation of space in blind persons: vision as a spatial sense?," *Psychological bulletin*, 121-1, pp. 20, Jan. 1997.
- [17] A. G. Dodds, C. I. Howarth, and D. C. Carter, "The mental maps of the blind: The role of previous visual experience," *Journal of Visual Impairment & Blindness*, Jan. 1982.
- [18] A. Vanlierde, and M. Wanet-Defalque, "Abilities and strategies of blind and sighted subjects in visuo-spatial imagery," *Acta psychologica*, 116-2, pp. 205-222, Jun. 2004.
- [19] Z. Bilda, J. S. Gero, and T. Purcell, "To sketch or not to sketch? That is the question," *Design studies*, 27-5, pp. 587-613, Sep. 2006.
- [20] R. Stake, *The Art of Case Study Research*. Thousand Oaks, CA: Sage, 1995.
- [21] J. Leydens, B. Moskal, and M. Pavelich, "Qualitative methods used in the assessment of engineering education," *Journal of Engineering Education*, 93-1, pp. 65-72, Jan. 2004.
- [22] E. Babbie, *The Practice of Social Science Research* (11th ed). Belmont, CA: Thomson-Wadsworth, 2007.
- [23] T. Wieggers, L. Langeveld, and J. Vergeest, "Shape Language: How people describe shapes and shape operations," *Design studies*, 32-4, pp. 333-347, Jul. 2011.