

A Capstone Laboratory for an Introductory Electronic Devices and Applications Course

**Theodore E. Fahlsing
Purdue University**

Abstract

The EET analog electronic devices-circuit analysis curriculum team at Purdue University, West Lafayette recommended an integrated circuit (I. C.) waveform generator lab for the capstone or final lab in the introductory electronic devices course. The objective is to introduce students to applications oriented analog integrated circuits. The 555 timer was used during the 1996-97 academic year. This choice was made mainly because this material was covered in the textbook. This was almost too fundamental and was supplemented by having the students investigate other integrated circuit waveform generators through a review of available literature in the library and/or on the world wide web. The following was developed to improve the rigor of this unit of the course.

Introduction

Special emphasis is placed on the selection of an integrated circuit waveform generator by a comparison of device specifications. The fundamentals of operation of the 555 timer in the astable mode is still covered in the lecture, reading assignments, homework, quizzes and tests. The lab now focuses on the investigation and demonstration of the specifications of integrated circuit function generators. The goal is to introduce skills required for students to become proficient in reviewing literature to select several I. C. waveform generators, reading the corresponding data sheets, and completing the lab measurements to make comparisons required for an informed choice of an I. C. for a particular application. The two I. C. function generators utilized for this lab are Exar's XR2206 and Maxim's MAX038. Because of cost, the XR2206 (\$5) was selected for the students to purchase and test. The students were not required to purchase the \$20 MAX038. However, the data sheets, available on the world wide web, were used to make comparison to the XR2206.

Data Sheet Evaluation

The evaluation of devices from data sheets is a skill that requires some practice and the use of a systematic procedure. The students were presented the block diagram approach shown in Figure 1.

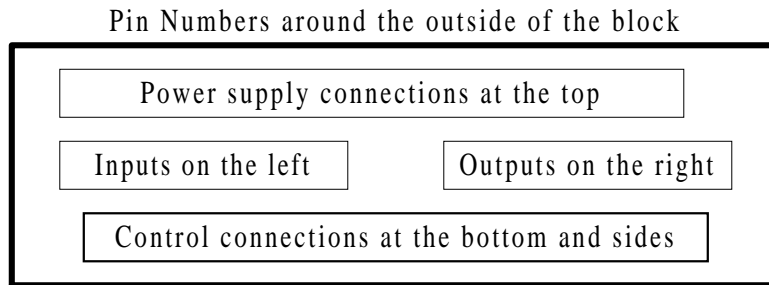

Figure 1: The Block Approach

This general approach may be used for developing the required documentation for the proper connections for most integrated circuits. Figure 2 is an illustration of what is required for the operation of an XR2206 using a single power supply.

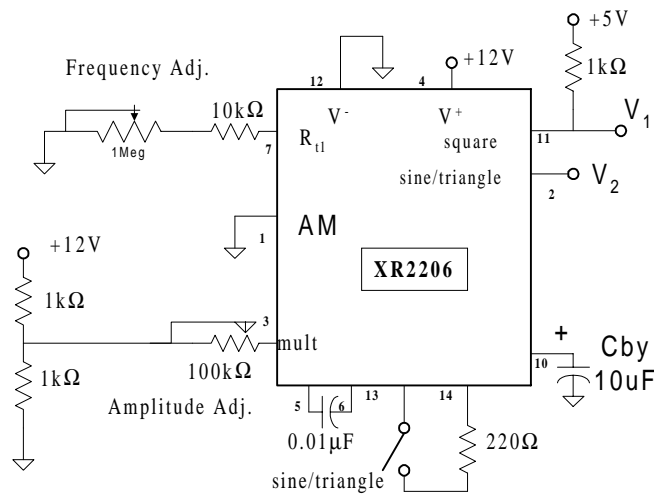

Figure 2: XR2206 Single Supply Operation

XR2206 Pedagogy

The students were directed through the XR2206 data sheets in lecture. The first specification discussed was the power supply requirements. The XR2206 can be operated either by single or dual supply. The specifications are absolute. The minimum voltage difference between V+ and V- is 10 volts and the maximum is 26 volts. The remaining features and control requirements were thoroughly discussed. The location of this information was identified in the data sheets to provide the students with an example of where to look for individual specifications such as what is required to achieve a sine wave output. A summary of this data can be found in Table 1.

MAX038 Pedagogy

Cooperative or team learning was the method used to cover the material found in the MAX038 data sheets. The class was divided into teams of four or five students and data sheets were given to each student. The teams were encouraged to divide the tasks of finding data between each team member. For example one person would investigate the power supply requirements, another the requirements for producing different waveforms, another how to vary the frequency of the output and each reported back to the team. The team was charged to duplicate as near as possible the functions of the XR2206 circuit in Figure 2. The time for this process varied from 15 to 25 minutes from team to team. Figure 3 is an illustration of the resulting block with power supplies and control requirements for the MAX038.

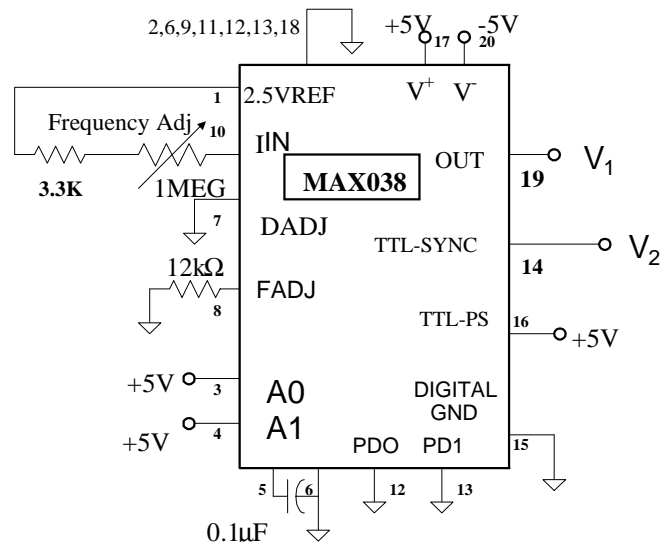

Figure 3: MAX038 Evaluation Circuit

Each team reported to the entire class any unusual observations in the comparison of the two I. C. waveform generators. The most obvious difference was the MAX038 power supply requirement of a dual plus and minus supply from 4.7 volts to 6 volts in magnitude. The other was that the fixed output voltage of the sine, triangle, and square wave of 2 volts peak to peak. The selection of the output waveform is set using two TTL/CMOS-logic address pins. It was also noted the MAX 038 contained an internal phase detector for use in a phase-locked loop. The class discussion continued to develop the following table for comparison of the two I. C. waveform generators.

Table 1: Comparison of XR2206 and MAX038

PARAMETER	XR2206 (2)	MAX038 (3)
Power Supply	10 to 26 volts	$\pm 5V \pm 5\%$
Frequency	0.01 to 1M Hz	0.1 to 20 M Hz
Freq. Sweep	2000:1	350:1
Amplitude Adj.	Yes	Fixed at 1V peak
AM/FM Generation	AM and FM	FM only
TTL Sync	Yes	Yes
Waveforms	Sine/Triangle	Sine/Triangle/Square
Waveform select	Switch and resistor	Two pin address
Ramp	Yes	None
Phase Detector	None	Yes
Duty Cycle	50%	50%
Cost	\$5.00	\$20.00

Conclusion

The students verified the XR2206 specifications through construction of the circuit and lab measurements. The MAX038 circuit was constructed on one breadboard for students to examine. The benefit to the students was in their increased awareness of the availability of various integrated circuits and the development of skills to evaluate and compare parameters of different integrated circuits. The addition of the cooperative learning exercise was extremely beneficial in demonstrating the value of team problem solving because the students were acutely aware of the fact that each would have spent hours instead of minutes with the MAX038 data sheets to complete the evaluation circuit in Figure 3. The exercise provided an excellent opportunity to discuss an evaluation procedure to identify the criteria used in the selection process of an integrated circuit for a specific application.

References

1. Boylestad, Robert L. and Nashelsky, Lois, *Electronic Devices and Circuit Theory*, Prentice-Hall, Inc. Englewood Cliffs, N.J. (1996).
2. Exar Integrated Systems, *XR2206 Monolithic Function Generator Data Sheet*, Exar, Sunnyvale, Calif.
3. Maxim Integrated Products, *MAX038 High-Frequency Waveform Generator Data Sheet*, Maxim, Sunnyvale, Calif.

THEODORE E. FAHLSING is an Assistant Professor of Electrical Engineering Technology at Purdue University, West Lafayette, Indiana. He received a B.S.I.Ed. from Purdue University and an M.S.I.Ed. from Southern Illinois University at Carbondale. His interests include applications of analog electronic devices, instructional methods, curriculum development, student outreach and alumni activities. He is a member of ASEE and IEEE.