

A New Curriculum to Teach System-Level Understanding to Sophomore Electrical Engineering Students using a Music-Following Robot

Mr. Son Nguyen, University of California, Davis

Son Nguyen received his Bachelor of Engineering degree in electrical and electronics engineering from Ho Chi Minh City University of Technology, Vietnam, in 2012, and his M.S. degree in micro and nano systems technology from University of South-Eastern Norway, in 2014. He is currently a Ph.D. candidate in the Micropower Circuits and Systems Group in the Department of Electrical and Computer Engineering at the University of California, Davis. He has interned and worked part time for Redpine Signals, Verily, and Google in power management integrated circuits, embedded systems, and wireless power transfer for wearable and implantable devices since 2016. His research interests include power management ICs, low-power mixed signal circuits, embedded systems, and wireless power transfer.

Prof. Andre Knoesen, University of California, Davis

Andre Knoesen received his Ph.D. degree from the Georgia Institute of Technology, Atlanta, in 1987. He is currently a Professor in the Department of Electrical Engineering, University of California, Davis. He performs research in sensors and nonlinear optical devices and their applications. Dr. Knoesen is a fellow of the Optical Society of America.

Dr. Hooman Rashtian, University of California, Davis

Hooman Rashtian received the Ph.D. degree in Electrical and Computer Engineering from the University of British Columbia, Vancouver, BC, Canada in 2013. He was a Postdoctoral Scholar at Davis Millimeter-Wave Research Center (DMRC) at University of California, Davis from 2014 to 2016. Since July 2016, he has joined the Department of Electrical and Computer Engineering at University of California, Davis as a Lecturer with Potential for Security of Employment (LPSOE). His educational research interests include curriculum innovation for teaching circuits, electronics and control systems, project-based learning, and the use of technology in teaching and learning.

A New Curriculum to Teach System-Level Understanding to Sophomore Electrical Engineering Students using a Music-Following Robot

I. Abstract

Electrical Engineering students usually have to wait a long time before acquiring the mathematics and physics prerequisites required to take their first technical courses and even when they take courses such as circuits, electromagnetics and digital logic, they are not given an opportunity to develop a system-level understanding about the interrelation of the topics that they study in these courses. In fact in many electrical engineering programs, students have to wait until their senior year before they can work on real engineering projects which require system-level understanding about interrelation of different fields such as analog circuits, digital systems, signal processing, etc. This long wait time causes some students to lose their interest in electrical engineering and decide to switch majors. To address this retention problem, we have come up with the idea of designing a 4-unit project-based required course for sophomore students. In this class, students are briefly introduced to several of the topics that will be covered in detail in their upcoming junior and senior years. At the same time, they design a complete system as the course project that involves applying this introductory knowledge of different branches of electrical engineering into an actual engineering project.

The course project is a music-following robot implemented using Texas Instruments Robotic System Learning Kit (TI RSLK) which locates the direction of music being played in the room and moves toward it until it reaches to the speakers playing the music. The important feature of this project is that it includes various components which cover a broad range of topics in electrical engineering curriculum and their interrelation. For example, students work with two (right and left) microphones as their sensors to detect audio signals, they work with analog op-amp amplifiers to amplify the sensed signals, they send the amplified signals to TI MSP432 microcontroller to convert them to digital signals and finally they process them in digital domain to control the direction of movement of the RSLK robot. For the microcontroller programming, students work with Code Composer Studio to write their codes and to assist them with the coding, templates are provided to them which they are required to complete based on their own algorithms. Some of the microcontrollers topics that students are exposed to include working with general-purpose input/outputs (GPIOs), analog-to-digital converters (ADCs), timers, periodic interrupts and Pulse-Width Modulation (PWM).

II. Introduction

Introducing projects-based courses early in the curriculum has been reported before. However, most of the reported works focus on specific fields within electrical and computer engineering. For example, the work in [1] proposes an interesting course in digital design and image processing to help students work with video systems while the course in [2] focuses more on software design for internet-of-things applications. Freshman or sophomore students usually have problems in finding their interests and they wonder which branch of electrical and computer engineering they should follow in their junior and senior years. To help students determine what they are interested in, this course is designed to provide students with a basic knowledge and hands-on experiences in different disciplines of electrical engineering and to teach them how engineering systems are designed and implemented. Unlike senior design project courses such as [3-7], the most challenging issue in developing a sophomore-level project-based course is designing a project which is not too difficult for students with basic technical knowledge while it is complicated enough to be consisted of multiple sub-systems from different fields. Other goals of developing such a course are to introduce students to circuit simulation, circuit prototyping, soldering and microcontroller programming.

In the past, the project of the course used to be an electronic system which would record vocalizations and it could locate the direction of a vocalization in a room using a servomotor. The servo motor could be controlled by a microcontroller together with LabVIEW. However, after the release of Texas Instruments Robotic System Learning Kit (TI RSLK), a major update was applied to the course in Spring 2018 to make the final project more rigorous and at the same time more exciting for students. The current final project is design of a robot (Figure 1) which is equipped with two microphones and can detect the location of sound and/or music being played from speakers and can move toward it.

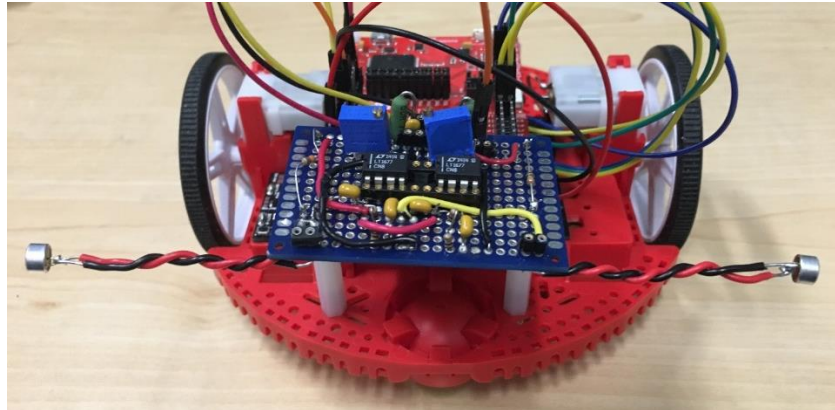

Figure 1: Music-following robot using TI RSLK kit

In the following parts of the paper, the course structure is discussed first and then the details of the laboratory experiments of the course are explained.

III. Course Structure

The course begins with a series of lectures on basics of electrical circuits accompanied by weekly laboratory experiments which allow students to apply their understanding from the lectures to build and test circuits in the laboratory. The laboratory experiments prepare students for performing electrical measurements using National Instruments MyDAQ which is a portable data acquisition device. The purpose of using MyDAQs instead of conventional lab equipments is to allow students to work on their circuits outside the lab hours. Students are provided with MyDAQ devices in the first day of the class and they can use them at home or in the lab throughout the quarter. Moreover, students are exposed to working with simulation tools such as LTSpice, MATLAB and Simulink to simulate electrical circuits and to design signal processing algorithms.

The course roadmap is shown in Table 1. As it can be observed from this roadmap, the laboratory experiments of the course cover a wide range of topics from analog circuits to microcontroller programming for digital systems. For programming MSP432 microcontroller, students use Code Composer Studio from Texas Instruments (TI) and they work with General Purpose Input/Outputs (GPIOs), SysTick timers and analog-to-digital converters (ADCs), periodic interrupts and pulse-width modulation (PWM). The final laboratories of this course cover control circuits for DC motors, PWM control and motor driving circuits. Finally, after learning necessary theoretical lectures, and performing several simulations and lab experiments, students design their own systems for the final project of the course.

Table 1. The roadmap of the course.

Week	Topic	Lab Topic
1-10	Participation, In-Class (5%)	
1	Course Overview Basics Concepts: Voltage, Current, Resistors	Lab #1: MATLAB Simulink
2	Capacitors and Inductors AC Circuits and Filters	Lab #2: myDAQ & DC Measurements
3	Operational Amplifiers Diodes & LEDs	Lab #3: RL and RC Circuits
4	Microphone Pre-amplifier	Lab #4: Operational Amplifiers
5	Audio Signals and Sampling, Analog-to-Digital Conversion, Digital Gates, Boolean Logic Microcontrollers: Architectures, ARM Cortex M, Memory Types (RAM, ROM), Data and address Busses, Memory Map, Registers, etc.	Lab #5: Microphone Pre-amplifier Soldering
6	MSP432: General Purpose I/O. MSP432: SysTick Timer & ADC	Lab #6: Sampling & Sound Recording
7	MSP432: ADC & Serial Communication (UART) Periodic Interrupts & Timers	Lab #7: DC Motor Control
8	MSP432: PWM DC Motors	Final Project: Part 1
9	Feedback Control Systems Filters & Comments on Final Project	Final Project (Cont'd)
10	Review: Final Exam	Final Project Check-offs

Figure 2 shows the block diagram of the system that is implemented as the final project. Students first construct an audio-sensing circuit with two microphones which detect audio signals coming from a speaker and convert the sound signals into electrical signals. Then, they will design filters and amplifiers to reduce noise and amplify the input signal which is subsequently sent to the analog-to-digital converter of the microcontroller. After, the data is in digital domain, the microcontroller controls the movement of RSLK by comparing the strength of signals picked up by the right and the left microphones.

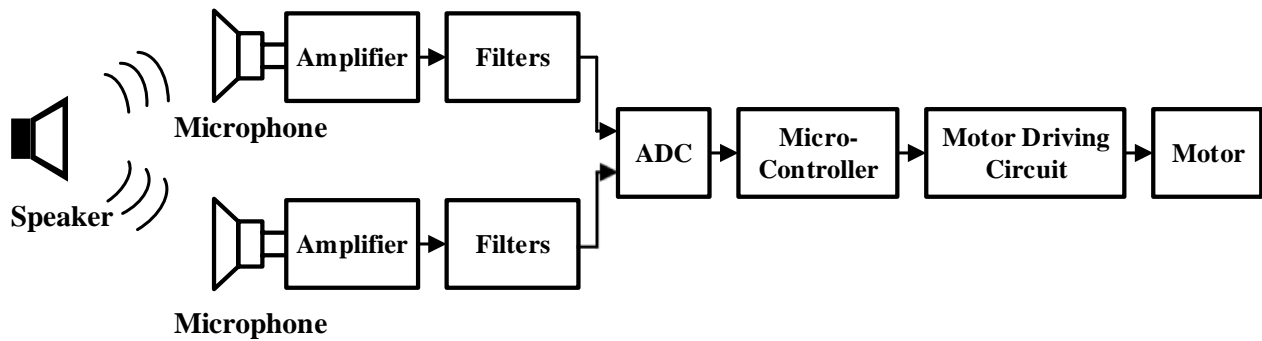

Figure 2: System diagram of the sound-following robot

IV. Laboratory Experiments

In this section, more detailed information about the laboratory experiments is provided.

1) Transducers, biasing circuits and DC blocking capacitor:

Electret microphones are used to detect and convert sound waves into electrical signals. An integrated amplifier is built in with the microphone and therefore students are required to design a bias circuit for it as shown in Figure 3. Furthermore, students perform measurements and compare the voltages before and after the coupling capacitor to understand how DC blocking capacitors work.

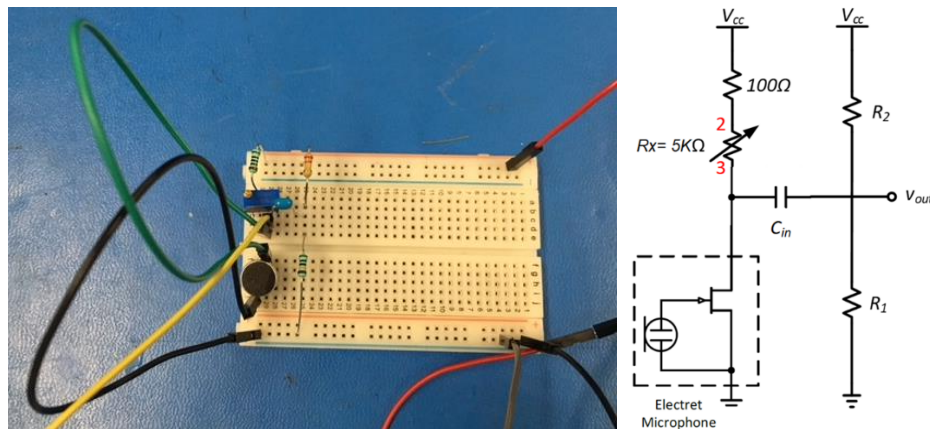

Figure 3: Microphone bias circuit on breadboard.

2) Filter and Amplifier:

After designing the biasing circuit for the microphone, students work on their analog circuit interface including filters and amplifier to build a bandpass active filter with the frequency bandwidth of 20Hz to 20KHz as shown in Figure 4. To help students understand the operation of the circuit, different debugging steps are used. For example, students are first asked to build the amplifier without C_1 and C_3 in Figure 4 to test the gain of the amplifier. Then, they obtain the Bode plot of the amplifier by performing a measurement on their amplifiers using MyDAQ when the capacitors are added back to the amplifier circuit. By inserting the capacitors to the circuit one by one, students will understand how each of the capacitors contributes to the low and high cutoff frequencies of the bandpass filter.

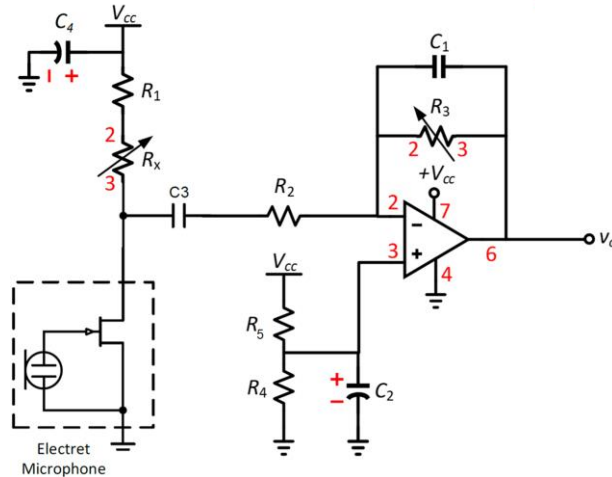

Figure 4: Filter and amplifier for the sound detecting system

Students first implement their circuits on their breadboards and then they replicate them onto prototype boards as shown in Figure 5. A soldering tutorial is given to students to teach them how to do soldering. The idea is to have students first build their circuits on breadboards which provide them with the option to change and modify their circuits if they make mistakes and once they have a working circuit which is ready to be mounted on RSLK, they transfer their designs onto a prototype board which has more physical stability.

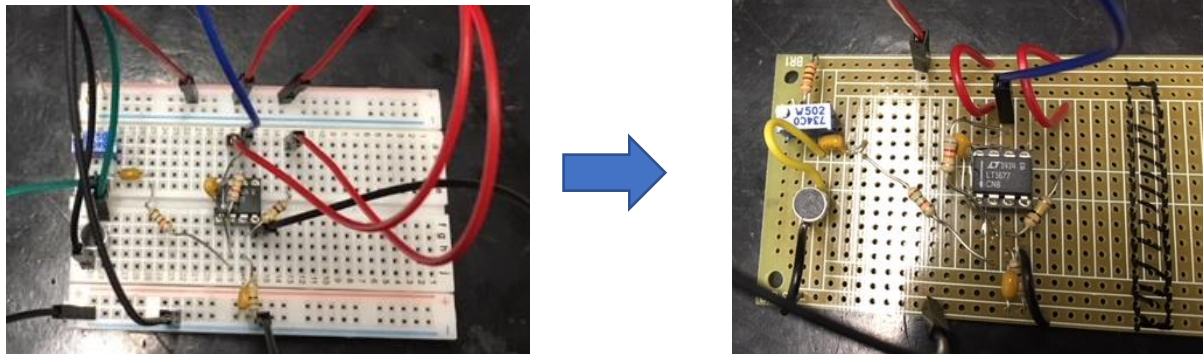

Figure 5: Sound detecting circuit on a breadboard and a prototype board

3) LTSpice and MATLAB Simulation:

To understand the operation of circuits and systems that they work on, students are instructed to work with two simulation tools: LTSpice and MATLAB/Simulink. For instance, students can simulate the audio amplifier circuit by modeling the microphone as a voltage-dependent current source as shown in Figure 6. By using MATLAB, students can perform a test control of their algorithms and they can process the data that they collect from their sensors. For example, in one of the experiments, the microcontroller is programmed to send the sensed data to a laptop through UART and students use MATLAB to process the data, plot the data and display the frequency spectrum of audio signals (Figure 7).

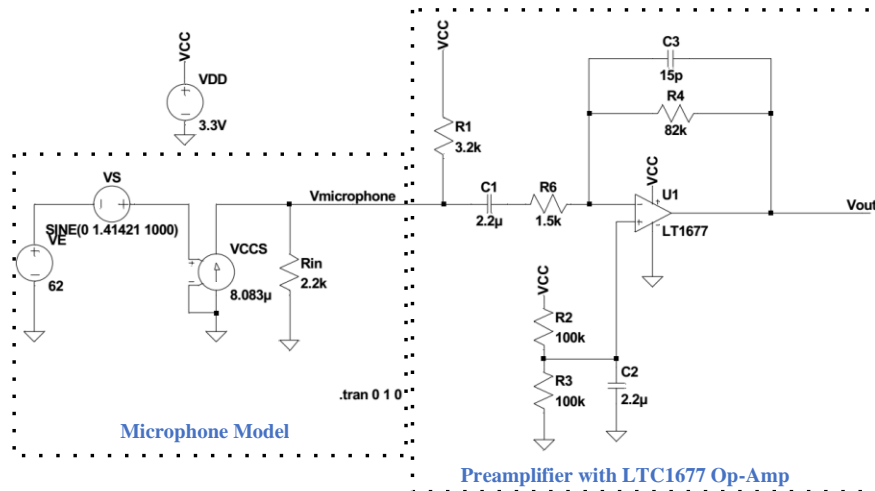

Figure 6: The schematic of the audio amplifier circuit in LTSpice

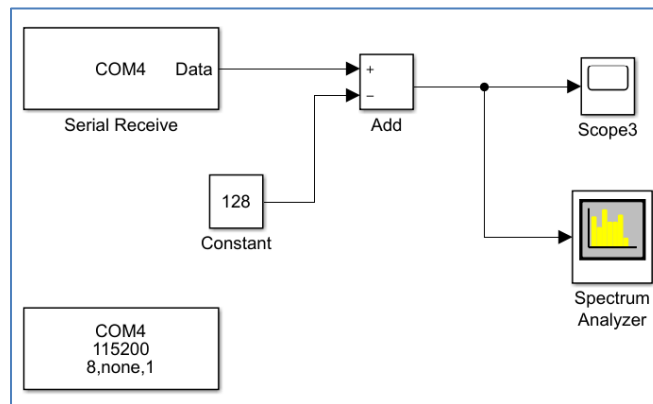

Figure 7: Using MATLAB and UART communication for plotting the frequency spectrum of audio signals

4) Code Composer Studio (CCS) and CCS Cloud:

As mentioned before, students program TI MSP432P401R LaunchPad that is included in the TI RSLK by writing C codes in Code Composer Studio (CCS). Unlike Arduino IDE, CCS allows student to debug their codes more easily, and student can access, create and change their coding libraries. While students are provided with all of the libraries that they need for the lab, they have to understand how to use those libraries to make their codes work. The programming experiments start with easy assignments and gradually become more challenging when students get familiar with the coding. For example, they may first work on toggling an LED and then reading sensor signals through ADC or controlling a motor by generating PWM signals. A challenge that was encountered was the existence of software bugs for Mac version of CCS and to solve that problem, CCS Cloud was adopted. A nice feature about CCS Cloud is that students do not need to install the CCS IDE on their laptops and can use the software remotely.

5) Analog-to-Digital Converter (ADC):

After amplifying the audio signal by using the amplifier, students learn how to sample the input signal through programming the analog-to-digital converter of the microcontroller. To convert the analog signal to a digital signal, students work with the internal ADC of TI MPS432. To practice working with ADCs,

students are instructed to compress the 16-bit data into 8-bit data or control an LED light intensity based on the change of the ADC input. Students are also taught why they need to use a sampling frequency two times larger than the audio signal frequency. For performing measurements on analog circuits (biasing circuit, filters, amplifiers), students use MyDAQ and NI ELVISmx while when working with the microcontroller, students are instructed to send the digital data from the microcontroller to a laptop through UART and to perform their signal processing analysis in MATLAB/Simulink.

6) PWM Control and DC Motor

The RSLK has a flexible chassis, two DC motors, batteries and driving circuits. Students first need to assemble all parts of the robots with the help of the teaching assistants and the provided instructions and then they begin learning to control the robot by programming the microcontroller to make robot go forward, turn left/right, or move backward. Controlling the motors of RSLK while sampling the audio inputs requires the microcontroller to work with multiple tasks at the same time. Therefore, to implement both audio sampling and PWM controlling simultaneously, students are taught to use and program timers and interrupts for microcontroller. For instance, in the main function, students generate PWM signals to make robots move forward while timers in the microcontroller are counting up. When the timers reach the sampling period, the microcontrollers will go to timer interrupt function to get the data sampling signals from ADCs.

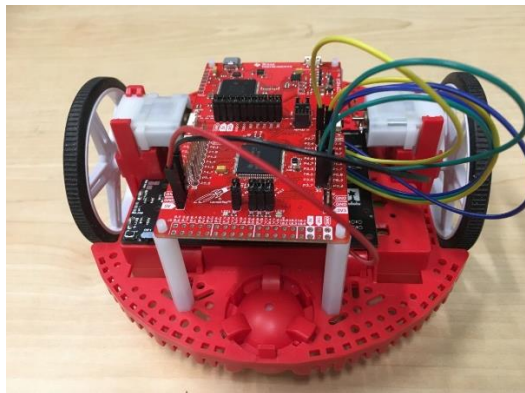

Figure 8: TI RSLK with TI MSP430 microcontroller, DC motor and driving board

7) Final Project

With all the knowledge and hands-on experiences that students have learnt from the previous labs until this point, they are eventually ready to work on their own project to build a music following robot. The final project allows student to think out-of-the-box by finding the best algorithm which results in the fastest localization of the speaker playing a music by the robot. During the final project evaluation, the TAs or instructor play one selected song with a speaker and students will demonstrate that their robot can move toward the speaker as quickly as possible. To find the speaker, the robots use left and right microphone channels and compares the strengths of the received signals.

One of the challenges is to determine the accurate location of the speaker. Therefore, students need to develop an appropriate algorithm to make the robot estimate the distance and direction of the speaker. For example, instead of comparing only RMS values of the audio signals from left and right microphones (which depends on the distance between the speaker and robots), students can use the relative RMS value which is equal to the ratio of the difference of the RMS values of the signals coming from the right and the left microphones to their average value to predict the best directions that the robots should move towards.

To make the final lab more appealing, the top three students with fastest robots which move to the speaker within the shortest time receive extra points.

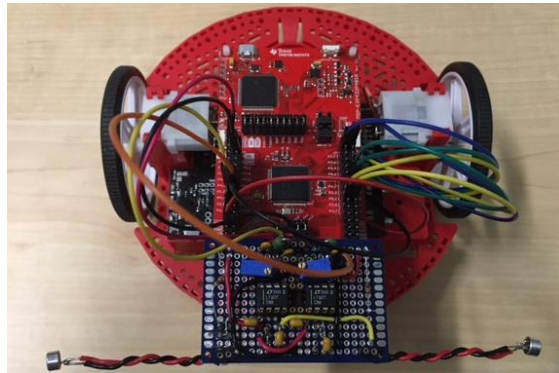

Figure 9: Completed music-following robot

Conclusion

This paper presents a ten-week course to teach system-level understanding to sophomore students in electrical and computer engineering. Throughout this course, students not only improve their basic knowledge in electrical and computer engineering and their hands-on skills but also are introduced to different fields of study that they may want to pursue in their junior and senior years. Based on the preliminary surveys and course evaluations, the course is successful in motivating students and to introduce them to different important topics in electrical and computer engineering. For future work, the plan is to obtain the IRB approval to collect assessment data about subjective experience of students in the class as well as their performance in in their future downstream junior and senior years.

Acknowledgments

This work is supported by Texas Instruments. The authors would like to thank Jason Rubadue at Texas Instruments for his support.

References

- [1] Chu, P. P. (2016, June), Integrating Computer Engineering Labs with a "Sound Theme" Paper presented at 2016 ASEE Annual Conference & Exposition, New Orleans, Louisiana.
- [2] Barendt, N., & Sridhar, N., & Loparo, K. A. (2018, June), A New Course for Teaching Internet of Things: A Practical, Hands-on, and Systems-level Approach Paper presented at 2018 ASEE Annual Conference & Exposition , Salt Lake City, Utah.
- [3] Zhang, L., & Badjo, J., & Dabipi, I. K., & Tan, X. (2017, June), Board # 53 : On the Design of Exoskeleton Suit: An Interdisciplinary Project Development Platform for Experiential Learning in Engineering Education Paper presented at 2017 ASEE Annual Conference & Exposition, Columbus, Ohio.
- [4] Danowitz, A., & Benson, B., & Edmonds, J. (2017, June), Board # 48 : Teaching Systems and Robotics in a Four-Week Summer Short Course Paper presented at 2017 ASEE Annual Conference & Exposition, Columbus, Ohio.

[5] Carlson, C., & Day, D. (2017, June), Transformation of an Introductory Computer Engineering Course Utilizing Microprocessors and a Focus on Hardware Limitations Paper presented at 2017 ASEE Annual Conference & Exposition, Columbus, Ohio.

[6] Watkins, M. A. (2018, June), Design and Implementation of a Health-monitoring Design Project in an Introductory Digital Design Course Paper presented at 2018 ASEE Annual Conference & Exposition , Salt Lake City, Utah.

[7] Rashtian, H., & Ouyang, J. (2017, June), A New Application-Oriented Electronic Circuits Course for non-Electrical Engineering Students Using Arduino and NI VirtualBench Paper presented at 2017 ASEE Annual Conference & Exposition, Columbus, Ohio.