

## **A Reconfigurable and Modular Hardware for Remote Learning of Analog Circuit Design**

### **Mr. Yixin Xiong, Penn State University**

Yixin Xiong is a senior student at the Pennsylvania State University, majoring in Electrical Engineering with a concentration in circuits and electronics. His interests in circuits were developed in a music processing circuit design project in a major course, and enhanced in later higher-level circuits design courses. He is planning to attend graduate school after graduation to study deeper in this field.

### **Stephen Porter, Penn State University**

Stephen is a recent graduate of Penn State interested in discrete circuit design. He currently works in the high-tech product design industry.

### **Swaroop Ghosh, Pennsylvania State University**

Swaroop Ghosh received the B.E. (Hons.) from IIT, Roorkee, India, the M.S. degree from the University of Cincinnati, Cincinnati, and the Ph.D. degree from Purdue University, West Lafayette. He is an assistant Professor at Penn State University. Earlier, he was with the faculty of University of South Florida. Prior to that, he was a Senior Research and Development Engineer in Advanced Design, Intel Corp. At Intel, his research was focused on low power and robust embedded memory design in scaled technologies. His research interests include low-power circuits, hardware security, quantum computing and digital testing for nanometer technologies.

Dr. Ghosh served as Associate Editor of the IEEE Transactions On Computer-Aided Design (2019-) and IEEE Transactions On Circuits and Systems I (2014-2015) and as Senior Editorial Board member of IEEE Journal of Emerging Topics on Circuits and Systems (JETCAS) (2016-2018). He served as Guest Editor of the IEEE JETCAS (2015-2016) and IEEE Transactions On VLSI Systems (2018-2019). He has also served in the technical program committees of ACM/IEEE conferences such as, DAC, ICCAD, CICC, DATE, ISLPED, GLSVLSI, Nanoarch and ISQED. He served as Program Chair of ISQED (2019) and DAC Ph.D. Forum (2016) and track (co)-Chair of CICC (2017-2019), ISLPED (2017-2018) and ISQED (2016-2017).

Dr. Ghosh is a recipient of Intel Technology and Manufacturing Group Excellence Award in 2009, Intel Divisional Award in 2011, Intel Departmental Awards in 2011 and 2012, USF Outstanding Research Achievement Award in 2015, College of Engineering Outstanding Research Achievement Award in 2015, DARPA Young Faculty Award (YFA) in 2015, ACM SIGDA Outstanding New Faculty Award in 2016, YFA Director's Fellowship in 2017, Monkowsky Career Development Award in 2018, Lutron Spira Teaching Excellence Award in 2018 and Dean's Certificate of Excellence in 2019. He is a Senior member of the IEEE and the National Academy of Inventors (NAI), and, Associate member of Sigma Xi. He serves as a Distinguished Speaker of the Association for Computing Machinery (ACM) for a 3 year term (2019-2022).

# A Reconfigurable and Modular Hardware for Remote Learning of Analog Circuit Design

Yixin Xiong, Stephen Porter, and Swaroop Ghosh

The Pennsylvania State University

Email: ykx5070@psu.edu, saporter97@gmail.com, szg212@psu.edu

## Abstract

Analog designs are complex compared to their digital counterpart. COVID-19 has precluded a large number of undergraduate students from entering the lab and gaining hands-on experience for theoretical concepts taught in online classes. This has affected the conceptual understanding of the topics and degraded student motivation. We developed a Do-It-Yourself (DIY) compose-able virtual hardware board (located in a lab remotely) to enable remote learning for courses such as analog circuit design. The board consists of remotely selectable hardware components such as transistors, logic gates (combinational and sequential), and passive (e.g., resistors and capacitors) components using multiplexers controlled through myDAQ (a commercially available hardware that interfaces with the board). These components can be composed on a breadboard to create a desired circuit (such as, common source amplifier with specified gain) remotely by sending commands to the myDAQ by a software interface for virtual experiments. The output of the board can be digitized and sent to the student's PC for visualization. The proposed setup can be time-shared with multiple students and can also be easily replicated. This framework is modular (i.e., other components like an extra breadboard with new designs can be added) and is also useful in the longer-term by allowing the students to personalize their learning. The effectiveness of the board has been assessed via a limited piloting on two Senior Undergraduate students who have been involved in this project.

## 1. Introduction

The existing research and curriculum alarmingly lack hands-on learning of analog and mixed signal and Radio Frequency (RF) Integrated Circuits (ICs). Analog designs e.g., amplifiers, Analog-to-Digital Converter (ADC), Digital-to-Analog Converter (DAC), filter and voltage regulators, and RF ICs are part of nearly all computing systems with applications ranging from healthcare, mobile, internet-of-things to supercomputers. The analog design market is worth more than \$45 Billion according to Semiconductor Industry Association (SIA) [1]. The challenge associated with analog designs is that they are very complex and involve careful choice of device dimensions, layouts, parasitic, amount of feedback and input amplitude/frequency ranges to maintain performance metrics (e.g., gain, bandwidth, linearity, phase/gain margins, signal-to-noise ratio and so on) and stability. The designs are also very sensitive to noise, dynamic and statistical variations and a small shift in operating point can cause oscillations and malfunction. For example, a minor alteration in R and C can shift the pole and zero location of a feedback amplifier making it oscillate.

There is a gap between the analog designs, their complex design space and existing didactic teaching style which affects the student learning negatively. A focused “hands on” curriculum to convey the practical analog designs to potentially bridge this gap. The proposed curriculum will resolve this issue through planned activities, assessments, and projects on the proposed test boards. By facilitating remote access to the test boards, pre-recorded lectures, well-documented activities, and flexibility to the students to run their chosen experiments on analog designs at their own convenience the proposed research will also address “Advance Personalized Learning” which is a NAE Grand Challenges in Engineering [2]. Existing undergraduate (UG) courses on analog designs introduce the concepts at theoretical level which do not provide the desired visibility to the students. Therefore, the students lack practical understanding and technical insights. With growing importance of analog design, it is utmost important to prepare a workforce equipped with analog design knowledge. Such comprehensive understanding could only be possible by a dedicated hands-on course where students can learn the key concepts by designing and editing the hardware. Unfortunately, such extensive and deep flexibilities are not provided in current analog design curriculum. Furthermore, conditions such as, cost, availability,

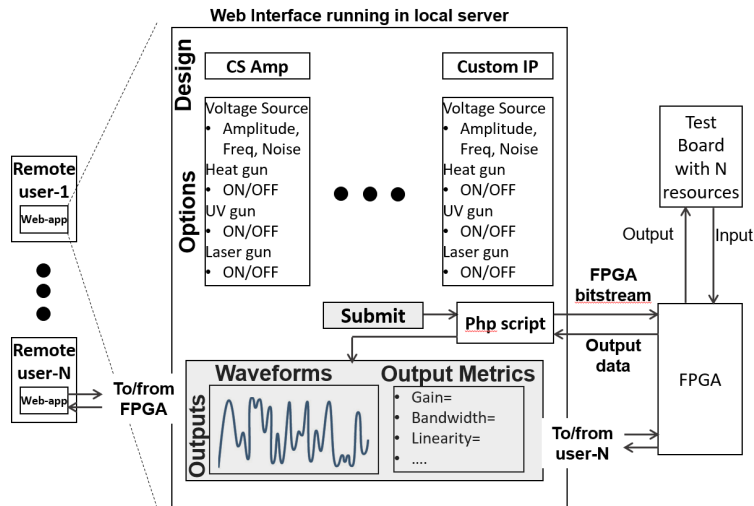

**Fig. 1 Overview of our approach.** The student will select the design for experimentation (or write a netlist) and enter the options. After submitting the request, a php script will compile the user selections to FPGA bitstream which in turn will apply the settings on the board using available resources. The sampled output from test board is collected by the FPGA and sent back. Multiple students will be able to execute experiments on the board simultaneously to run their test cases independently.

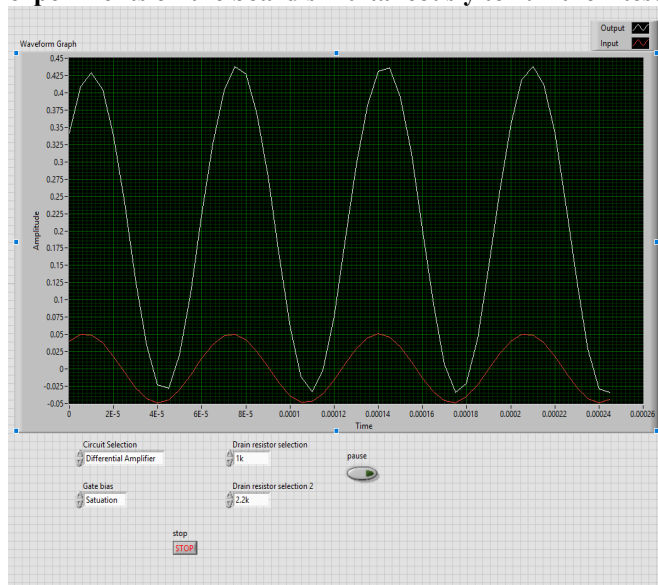

**Fig. 2 Graphical user interface.**

and pandemics e.g., COVID-19 preclude the students from accessing the hardware physically. In order to solve this issue, we propose a reconfigurable hardware board that can be accessed and controlled remotely.

**Fig. 1** shows the high-level vision of this work. The user end will have an application to obtain the user choices. The hardware end will have a FPGA and the hardware board. The FPGA will be programmed by the user application using a fixed template with some user driven variables to select the multiplexers in hardware board. Under ideal scenarios, the user application will be written in hypertext markup language (html) and cascading style sheet (css) to interface the user command/inputs with the hardware board. A hypertext preprocessor (php) script will be developed to process the user inputs and convert them in Verilog compiled bitstream to be fed to the FPGA at the hardware end which in turn, will apply the settings to the board to configure available resources and start the experiment. Precompiled and synthesized Verilog meta-functions will be used to map the user selections to corresponding FPGA bitstream directly. The sampled outputs from the hardware board will be collected by the FPGA and sent back to the user php script. The waveform and performance metrics will be displayed in user's output frame by the php script.

Due to challenges faced by FPGA, we use National Instruments (NI) myDAQ™ interface [3] with the analog hardware. LabVIEW has been used to send control signals from the user to NI myDAQ and read waveforms from the board. In addition, we present a detailed schematic and component usage, which can be used to reproduce this remote learning board easily.

The rest of the paper is organized as follows: Section 2 provides the details of the test board, its components, and experimental results; Section 3 describes our piloting and evaluation strategy; and Section 4 draws the conclusion.

## 2. Board Design

This section first explains the overview of the analog test board. This is followed by the details of the common source and differential amplifier designs and experimental results.

### 2.1 Overview

The design of the whole system consists of two parts--board and controller. In the controller design, LabVIEW has been chosen as programming language and myDAQ has been chosen as a cheap alternative to costly instruments. A user interface (shown in **Fig. 2**) has been designed by using this hardware and software to control the circuit and read the resulting output signal through a computer. The functionality of the board has been validated experimentally. In the board design, we created simple common-source and differential amplifier circuits. In order to help students to learn the effect of load and biasing points, two different loads were set up using different loading resistors. Various bias voltages are accomplished by using voltage dividers so that the MOSFETs can work in two different areas of operation. Each of the bias and load settings are user selectable. To switch between various circuit configurations, analog switches are utilized. In addition, the multiplexers are used to decode the digital control signal from the controller to actual signals that control the analog switches. The values of the resistors in the load are set to provide a proper gain and the resistor in the voltage dividers are fine-tuned using potentiometers at the set-up process and before the experiment to calibrate the working range of the amplifiers with respect to the tolerance of the transistor inside. The complete circuits are created first and the analog switches are added later. Due to the relatively low on-resistance ( $8\Omega$ )

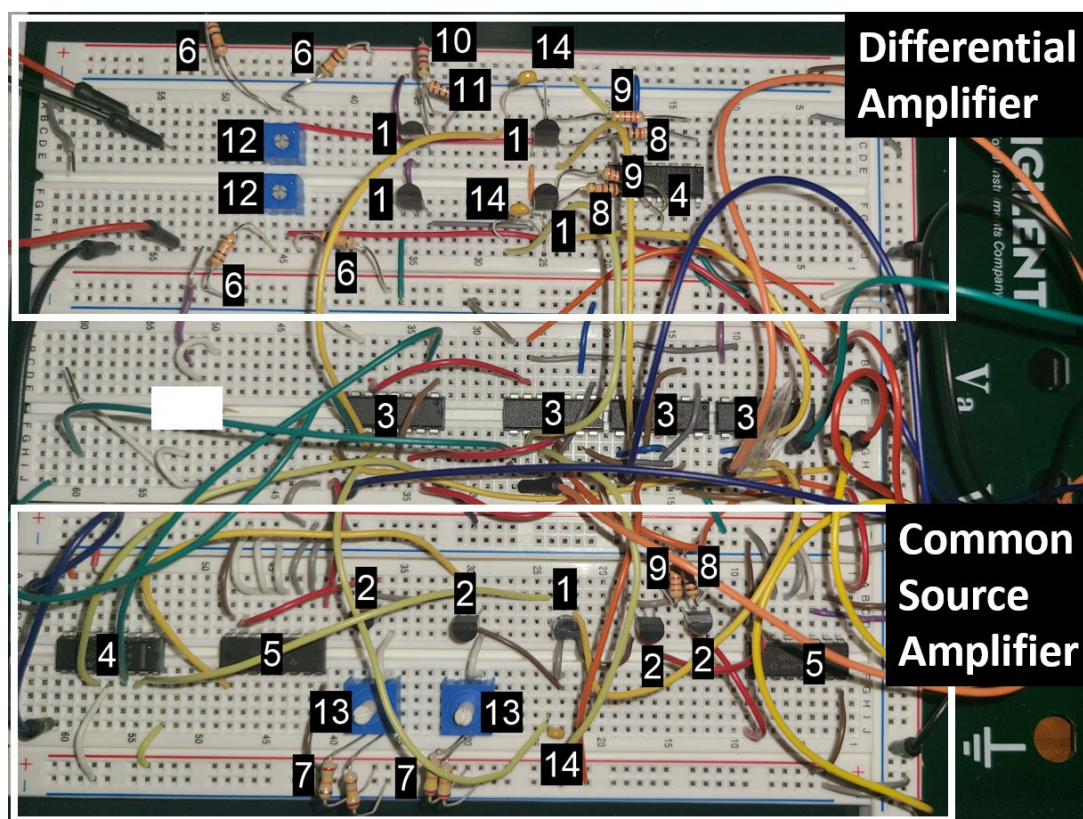

**Fig. 3** Physical layout of the board. Various components from Table-1 have also been labeled.

comparing to the tolerance of the smallest resistor (5% of 1kΩ gives 50Ω tolerance), the added analog switches have minimal effect on the pre-designed circuit.

## 2.2 Microcontroller Unit (MCU) Programming

We use myDAQ--a simple device as MCU to both control the circuit and read the result from the circuit. For the coding, we chose LabVIEW, a programming language with an embedded graphical user interface. Therefore, the completed program is able to provide a user-friendly interface for both controlling the circuit and reading the waveform.

## 2.3 Detailed Design Process

The designs have been assembled in a breadboard. The detailed design process is described below. The connections and the data & control signal flow is shown in Fig. 4.

2.3.1 Component List: **Table 1** shows the components used in this project along with the model numbers and quantities. These components are also labeled in Fig. 3.

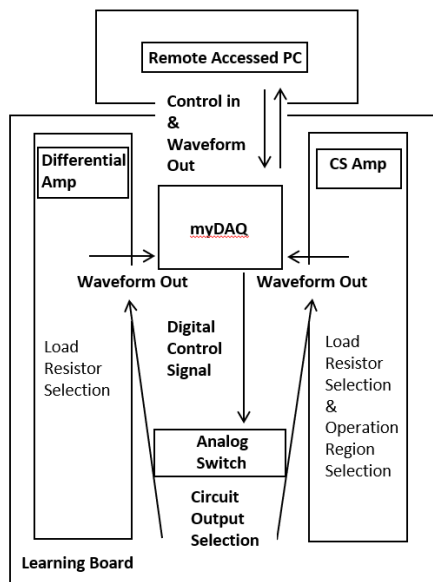

**Fig. 4** A High-level diagram of the connections and signal flow of the components. The myDAQ is the element that translates the control signal from PC to hardware elements and send the signal readout to the graphical user interface. The analog switch is used to select the proper waveform as output following the control signal from myDAQ.

**Table 1:** Detailed components of the board

Name	Model Number	Amount	Label
NMOS	2N7000	5	1
PMOS	VP2106	4	2
Analog Switch	MAX4614	4	3
Analog Switch	MAX4619	2	4
3:8 Decoder	SN74HC138	2	5
Resistor	10kΩ	4	6
Resistor	24kΩ	4	7
Resistor	1kΩ	3	8
Resistor	2.2kΩ	3	9
Resistor	2.7kΩ	1	10
Resistor	100Ω	1	11
Potentiometer	100kΩ	2	12
Potentiometer	10kΩ	2	13
Capacitor	100nF	3	14

2.3.2 *Common Source Amplifier*: **Fig. 5 (a)** shows the schematic of a conventional common source amplifier. The resistance load and the bias current can be tuned to obtain various gain values. **Fig. 5(b)** shows the proposed reconfigurable common source amplifier. This circuit is implemented in the 3rd block in the breadboard (from top to down) as shown in **Fig. 3**. The common source amplifier takes single ended input and amplifies the signal with respect to a common ground. The p-type MOSFETs are represented by mechanical switches shown on the schematic, the parallel MOSFETs are controlled by a decoder so that when one is ON the other is OFF. As shown in the schematic, the load can be switched between 1k and 2.2k by switch S1. Switch S2 is used to switch between saturation mode and triode mode. The two potentiometers R7 and R8 are fine-tuned before the experiment to create proper biases for transistor Q1 working under saturation and triode region, and to calibrate the current across the transistor Q1 with respect to its tolerance. The capacitor C1 is used to add a small signal with the DC bias from the potentiometer. The output is read from the drain of the n-type MOSFET.

2.3.3 *Differential Common Source Amplifier*: **Fig. 6(a)** shows the schematic of a conventional differential amplifier. The resistance loads can be tuned to obtain various gain values. **Fig. 6(b)** shows the proposed reconfigurable differential amplifier. This circuit is implemented in the 1st block in the breadboard (from top to down) as shown in **Fig. 3**. The differential amplifier has two inputs and two outputs, and the voltage levels are the relative voltage between those two terminals. A current mirror is set as a current sink. Also, similar to common source amplifier, the DC bias has been fine-tuned by the potentiometer in the voltage divider to make sure that both transistors working in the saturation region and having the same current flowing through under the tolerance of transistor Q3 and Q4. The bypass capacitors are also used to block the DC signal in the input while passing the AC signal. The analog switches are represented by the mechanical switches S1 and S2, which switches between different loads to achieve different voltage gain. The outputs are read from the drain of n-type MOSFETs Q3 and Q4.

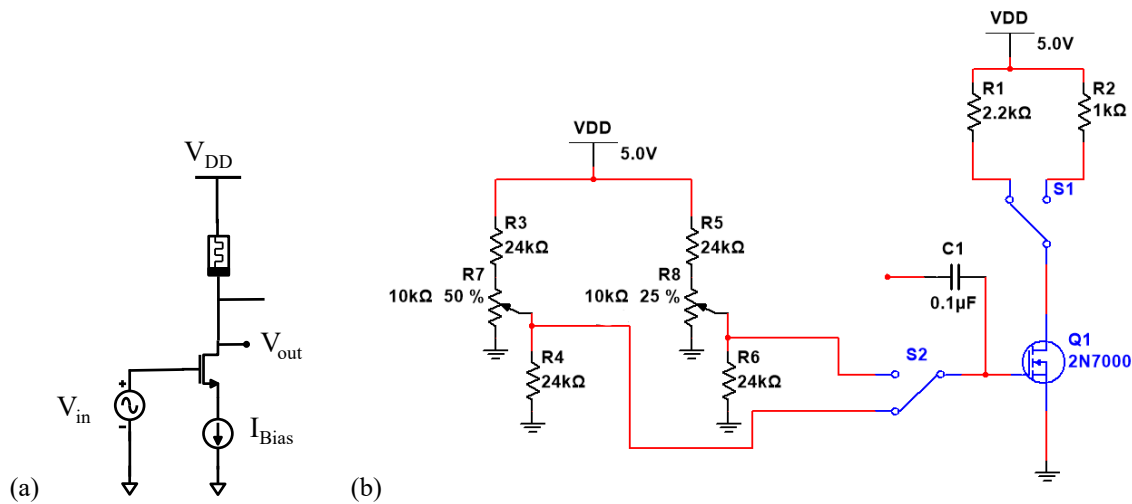

**Fig. 5** Schematic of, (a) common source amplifier; (b) proposed reconfigurable common source amplifier with tunable loads and current biasing implemented using potentiometers. The small signal input is applied through capacitor C1. The analog switches (S1 and S2) are also shown that the students will configure remotely.

## 2.4 Experimental Results

We have validated the common source and differential amplifiers for both saturation and triode regions of operation for various load and bias conditions. **Fig. 7** shows the input and output waveforms (yellow waveform is the input and green is the output). It can be noted that the peak-to-peak output (i.e., the gain of the amplifier) is increased by around a factor of two. The output starts to distort regardless of the load (1k or 2.2k) when modifying the amplifying transistor bias to the triode region. This is shown in **Fig. 8**. Therefore, the students can understand the effect of, (i) load resistance on the amplifier gain and, (ii) transistor biasing on output distortion via remote experimentations.

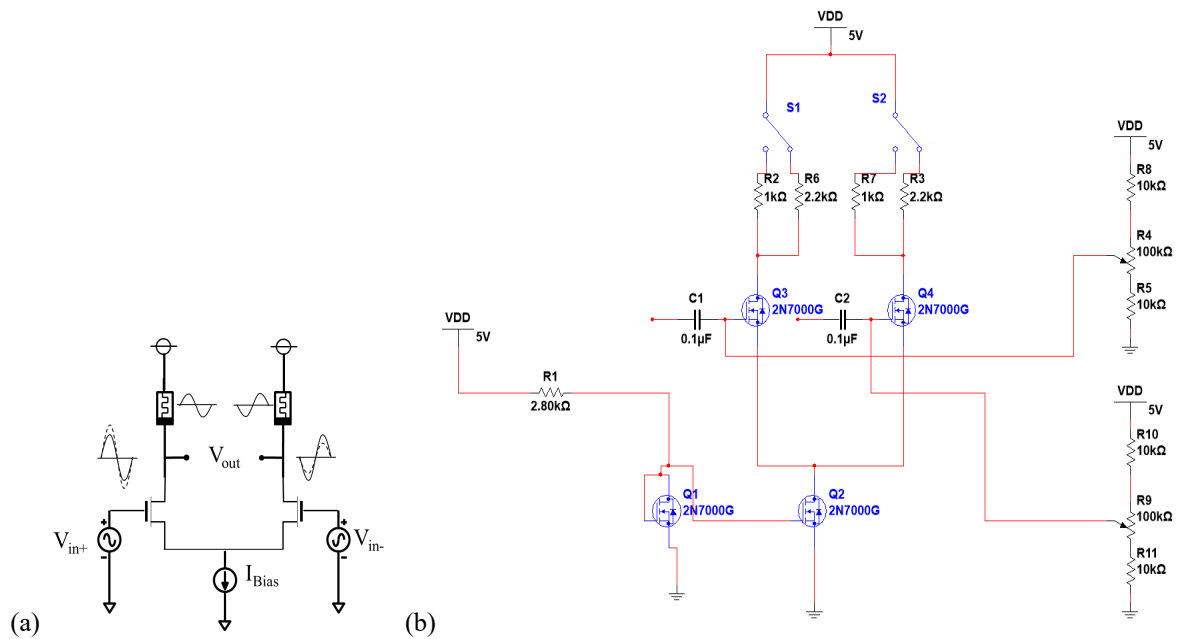

**Fig. 6** Schematic of, (a) differential amplifier; (b) proposed reconfigurable differential amplifier with tunable loads and current biasing. The small signal input is applied through capacitor C1 and C2. The analog switches (S1 and S2) are also shown that the students will configure remotely.

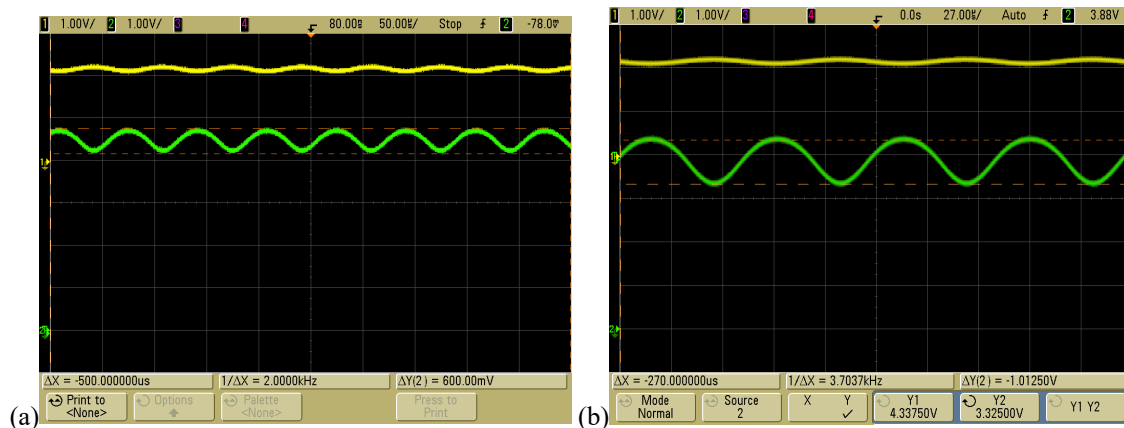

**Fig. 7** Common source amplifier working in saturation region with, (a)  $1\text{K}\Omega$  load resistor using switch S1 and, (b)  $2.2\text{K}\Omega$  load resistor using switch S2. The yellow waveform is small signal input whereas green waveform is the amplifier output.

We also repeated the experimentation on differential amplifier. The oscilloscope waveforms (blue is the input and green is the output) in **Fig. 9** indicate the correct functionality of the circuit. The input is fixed  $15\text{kHz}$   $1\text{mVpp}$ , but the input tuning function can also be added to the program in the future. By switching the load from  $1\text{K}$  to  $2.2\text{K}$ , the gain increases by around a factor of two.

### 2.5 Other Experiments on the Board

Following extra experiments could be conducted for the CS and differential amplifier designs on the board:

- Gain vs bandwidth: The frequency of small signal input can be swept from low to high value to study the impact on gain. From the obtained results, the student can plot gain vs bandwidth to understand the trade-off.
- Distortion/non-linearity: The amplitude of the small signal input voltage could be swept to understand the input range for which the output is linear. The student can plot output distortion vs input voltage amplitude.

### 2.6 Future Extension of the Board

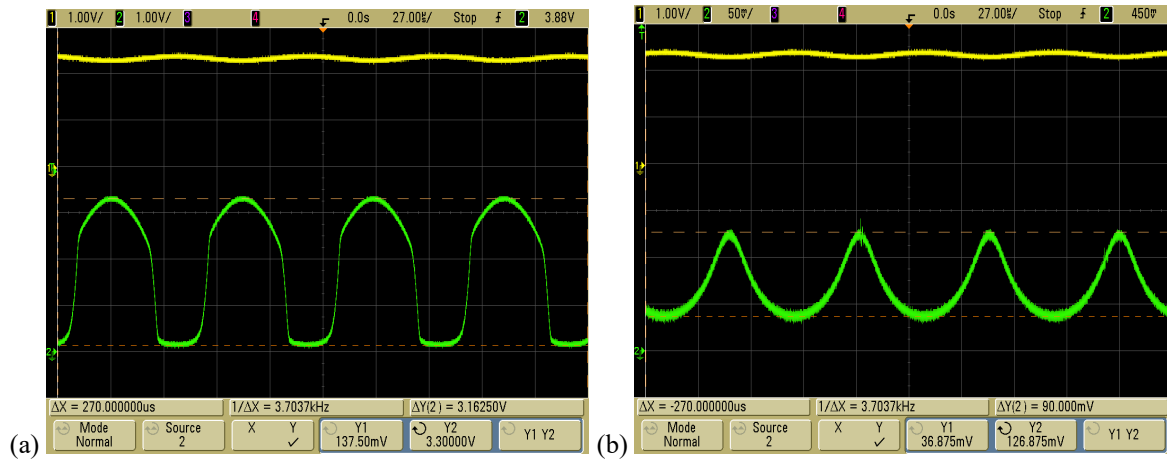

**Fig. 8** Common source amplifier working in linear region with, (a) 1K $\Omega$  load resistor using switch S1 and, (b) 2.2K $\Omega$  load resistor using switch S2. The yellow waveform is small signal input whereas green waveform is the amplifier output.

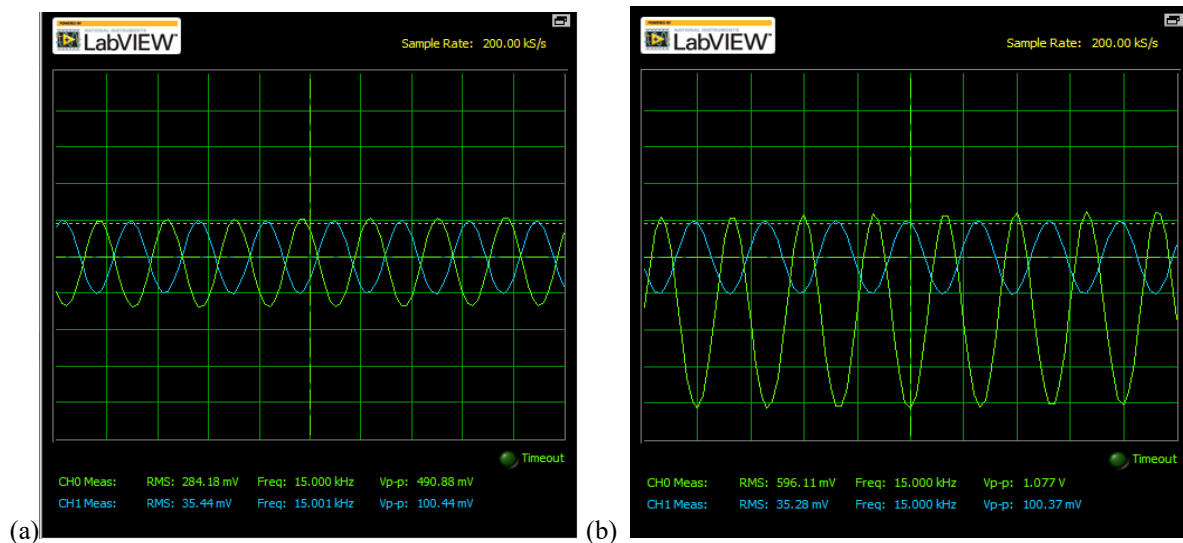

**Fig. 9** Differential amplifier working in saturation region with, (a) 1K $\Omega$  load resistor using switch S1 and, (b) 2.2K $\Omega$  load resistor using switch S2. Blue is the input and green is the output waveform.

Besides the existing circuits on the board, the users can also design their own analog circuits to meet the needs of different courses. This can be done by adding new templates in the board (similar to common source and differential amplifiers). Due to the use of analog switches, customized circuits can be controlled and read by simply connecting one extra switching channel to the analog switch chip for each new connection port. Some example designs are described below:

- Cascoded amplifiers: Common source amplifier (and also differential amplifier) design can be cascoded by stacking the amplifier transistor and the current source. The stacking transistor sizes and options (two vs three stacked transistors) could be selectable using multiplexers.
- Current mirror design: Passive resistance and PMOS/NMOS transistors can be configured to design a reference current source which can be mirrored to design source and sink current mirrors.

### 2.7 Limitations of the Board

- Limited choices of passive and active components: The proposed board offers only limited number of passive resistances that can be chosen by the user. The sizing choices are also limited. The design



choices can be expanded by adding more selectable components using multiplexers at the cost of extra complexity and parasitic capacitance loading that can affect the design performance.

- Prior tuning: Pre-tuning of the biasing potentiometers is done during lab setup and they are fixed from that point on. Therefore, run-time tuning of biasing is not supported.
- Limitations on the number of experiments: Currently, the board can support study of gain, bandwidth and linearity. Any other aspect of the study is not supported (although can be expanded).
- Limitations on the number of designs: Currently, the board can only support limited number of designs. However, the number of designs can be expanded at the cost extra complexity.

### 2.8 Application of the Board

The potential applications of the board are, (i) remote access to hardware board by students under pandemics, (ii) enabling students to run the experiments at their own convenience; (iii) sharing the same hardware resource with multiple students in time multiplexed manner; (iv) remote offering of hands-on course on analog circuit design.

## 3. Educational Impact

### 3.1 Context

The primary purpose of the board is to convey the importance of various aspects of analog design to the students via hands-on experiments to support their lecture-based learning. The board is also intended to enable interested students in creating their own design and running their chosen experiments. This in turn, would nurture student’s curiosity in deciding future courses and career choices. In this paper, we have been able to conduct a limited survey to assess the above impact.

### 3.2 Details of Survey and Results

This test board has been developed by two Senior undergraduate students who have been surveyed before and after the test board activity to quantify the effectiveness of the board in shaping their future career, interests and understanding on various aspects of analog circuit design. Both students had taken Electronics-II coursework prior to joining this project which had exposed them to the basics of analog design. The survey questions (in the scale of 5) have been divided into 3 segments namely, (i) importance of various aspects of analog design in their career; (ii) their interest in analog design; and (iii) impact of the board in their understanding of analog design. We took the average score of the students’ responses as shown in **Table 2**.

**Table 2:** Summary of the survey on the experience of students involving in this project.

<b>Rate how important the following topics are to your future career:</b>			
Understanding of analog design	3.5		
Circuit and system design methodologies	5		
Practical application of analog design	4.5		
<b>Rate how interested you are in the following topics:</b>			
Amplifier circuit design	4		
Analog to digital converter and other analog building blocks	4.5		
State-of-the-art analog circuit design methodologies	3		
Quality metrics of analog design	2		
Evaluating various analog designs by simulation or experiment	5		
<b>Rate the following questions before and after this project:</b>			
	<i>Before</i>	<i>After</i>	<i>% Impr.</i>
Appropriately assess the relevance of my knowledge and skills to a project	4	4.5	12.5%
Clearly identify the type of knowledge and skills I bring to a project	4	5	20%
Think of ways other members have influenced a project in a way that represents their academic disciplines	4	5	<b>25%</b>
Discuss the contributions other disciplines have made to a project	3	5	<b>66.67%</b>
Accurately assess the extent to which my mastery of these knowledge and skills are adequate for this project	4	4	0%

Clearly identify the type of knowledge and skills possessed by teammates from other disciplines	4	5	<b>25%</b>
Accurately recognize goals that reflect the disciplinary backgrounds of other team members	3	3	0%
Talk about a project design using other discipline language	3.5	5	<b>42.86%</b>
<b>Average</b>			<b>24%</b>

From survey, it is apparent that both students have been interested in analog circuit design and a career in the same area. The pre- and post-survey indicated 24% on average improvement in various aspect of their skills that have been impacted by the project. They also found that the board tested their knowledge and skills of the theoretical knowledge gained from related courses. Future implementation of the board in classroom will be followed by more detailed survey and focus group meetings to assess its impact and obtain feedback to enhance the board.

#### **4. Conclusion**

We present a reconfigurable hardware board which compensates the difficulties of accessing actual hardware due to several reasons like COVID-19. This board can be controlled and read remotely and can be reproduced at ease with the component list that has been presented. Besides, this board is also highly customizable i.e., new modules can be added to this board based on the user needs with some minor changes to the board and the code. We have also evaluated the educational impact of this project by holding a survey to students involved in the design and assembly of this board, showing their improvement in understanding analog design during this project. In future, the board will be piloted with larger group of students in existing curriculum on analog circuit design. Compared to traditional laboratory experience where students need to access the physical stock room and laboratory room to get access to the physical parts and equipment to learn practical analog circuit design experience, the proposed method provides a cost-effective (remote access by a simple PC) and safe (no physical contact) alternative without compromising the important concepts and experiments in the curriculum. In addition, compared to the regular education in the laboratory, the proposed method also reduces the risk of injury due to improper operation of the experiment by the students via isolating the set-up and operation process to different people and different locations.

#### **Acknowledgement**

The work is supported in parts by National Science Foundation (NSF) (CNS-1722557, CCF-1718474, OIA-2040667, DGE-1723687 and DGE-1821766).

#### **References**

- [1] <http://www.eenewseurope.com/news/semiconductor-market-breakdown-and-2016-forecasts-0>
- [2] <http://www.engineeringchallenges.org/9127.aspx>
- [3] <https://education.ni.com/teach/resources/99>