

AGRICULTURAL IMPROVEMENTS THROUGH MECHATRONICS

Brian Linhares
brian.linhares@vaughn.edu

Sharifa Happy
sharifa.happy@vaughn.edu

Hossein Rahemi, Ph.D, advisor
hossein.rahemi@vaughn.edu

Vaughn College of Aeronautics and Technology, Flushing, NY, USA

Abstract: The development of agriculture and the machinery behind it was invented with basic cultivation skills within a green environment. We have seen how mechatronics has influenced the evolution of our agriculture, and how it is becoming the primary element of our future cultivating habits. Using mechatronics, our contemporary technology will be fused with our native elements of basic agriculture in the usage of “green,” less harmful components within the machinery that we use in our farms. Our prime example would be our concept of a “green” robot that is powered by the methods of using solar energy and an engine driven accessory gearbox. In addition, sensors such as ultrasound, and infrared are some of the vital components utilized by our concept of this fusion of Mechatronic engineering and agricultural development. Taking on a grasp of time, accuracy, and efficiency, tasks can be completed at a proficient rate compared to basic cultivating customs. The unique structure of this robot emphasizes on our journey back to a “green” ecology without removing the role of the farmer.

Keywords: Evolution, Mechatronics, Agriculture, Efficiency

In the balance of humanity, many see mechatronics as an obsolete field of “rocket science,” but few are aware that the printer is an innovation of mechatronics. The history of mechatronics began in 1969 with Tetsura Mori, an employee at Yaskawa Electric Corporation [1]. The term mechatronics is derived from the two general fields of mechanical and electrical engineering, and are bridged by computer science. Mechatronics engineering has already been applied in various components of technology that can be found in the present world. Included in these applications, but not limited to for mechatronics engineering, are the interactive systems on aircrafts, software systems in the field of design engineering, and in the technological aspect of the practice of medicine. Combining these applications and the many more that contribute to the development of our technological world, mechatronics has become a part of our evolution of agriculture.

From the history of advancements in technology, we can retrace back at the evolution of our world that we had created for ourselves (Figure 1). During the Industrial Revolution, we had all praised the use of steamships and factories without any consideration to how harmful they can become to our planet. Using mechatronics engineering, and combining fields that are not only related to science and technology, but also the biological territory surrounding us, we can evolve by working backwards. After having invented agriculture and machinery [2], devolution becomes the key to evolution based on the principles of using mechatronics to bring an industrialized world back to its origin of a healthy “green” ecology. To bring back a “green” ecosystem, scientists and engineers need to comprehend the importance of using technology that is less harmless to the environment.

Our natural tendency towards change journeys us through a cycle that envisions us to bring our knowledge and the tools of technology to keep designing our future of agriculture. We commenced agriculture with basic handmade cultivating tools, and then further advanced with

power machinery with a vision of efficiency, but were blind to the harm that was created. With the influence of mechatronics in agriculture, our ecology is gradually returning to its “green” state by diffusing it with technology that is not harmful but beneficial.

In the very beginning of agriculture, farmers utilized power from oxen and horses, and would leave the remaining work for manual labor. As a prime example, “two-hundred to three-hundred labor hours were required to produce five acres of wheat with a walking plow, a brush harrow, and a hand broadcast of seed, sickle, and flail” [3]. Time being an essential to agriculture was harder to grasp due to the extensive amount that was consumed by manual labor. In addition, the inefficient ways of cultivating opened doors for humans to be subjected to diseases and animal attacks.

Technology playing the role of the feeding hand to agriculture in this present era, elements of mechatronics, such as sensors, plays a vital role in our farms of fertilizing, seeding, cropping, cleaning, and monitoring our vegetation. In detail, we can see sensors in use of detecting color, alcohol levels for ripeness, ambient light levels, moisture levels and hazardous levels of chemicals including pesticides. We have also seen different mechanisms, such as robotic arms that cultivate the roots of plants and rotating mechanisms to seed, collect, and clean produce, and to revitalize the soil [4].

Taking into consideration a robot representing the engineering of mechatronics in the collection of crops, we can illustrate the various benefits that the components of the robot, such as sensors and moving mechanisms, power sources, and the composition of green elements can benefit a field of crops (Figure 2). With the use of laser sensors, we will accurately measure the height of the crops by scanning the crops in an angled projection. This then allows for the robot to self adjust its height to the height of the crop.

The ultrasound sensor will be detecting if there is something in front before mechanisms are activated. Controls will be using GPS guidance systems. Pullers, blades, and a conveyor belt will be the rotating systems, grabbing, cutting, and extracting the crops inside the robot. The soil sensor will be a panel collecting and analyzing the soil components, which is going to be followed by the collecting mechanism that will be holding the soil for analyzing moisture contents and more such as vitamins, minerals, and pesticide levels.

Cameras will be the robot’s and the controller’s eyes out in the field by feeding visual imagery back to the control center. In addition, the imagery of cameras will be attached with a symmetry indicator, allowing the robot to be in the middle of two parallel objects. The power system will consist of a two-cylinder engine attached to a generator, solar panels, and a back-up battery. The drive train wheels will include four big wheels in the front and rear. The conveyor belt will be classified as an accessory section item and will be attached to a specific area in the back for the convenience of a quick disconnect wire from the system.

The robot will also utilize gears to reduce the load on the motors. By attaching a gear with a greater surface area to the motor, and a gear of smaller surface area to the blade, we can increase the speed, and reduce energy consumption. The solar panels can help decrease power consumption by distributing energy among different mechanisms throughout the robot, and also

can help by reducing emissions through the reduction of output from the engine. Cost-efficient parts, such as PVC, steel blades, PVC pullers, and aluminum alloy chassis can be utilized. The pullers use a pulley system to adjust the height of the stalk pullers through the use of laser sensors. The arms can be made out of aluminum alloy and the outside body will be consisting of high tensile stress cloth, which is durable for the outside environment and holding the crops in a waterproof compartment. The disks are steel blades and the pullers will be made of PVC.

The challenge in utilizing an autonomous robot composed of mechanical and electrical features is to maintain its ecologically benefits. Not only is the strength of the robot taken into account, but also its beneficial attributes to the environment. Unlike wooden structures, which require approximately thirty to fifty years in order to grow back to their complete size, bamboo has an incredible growth rate that can reach up to almost four feet per day. As the fastest growing known plant on Earth, bamboo generates more oxygen, takes in more carbon dioxide, and requires less space for the plant to grow [5].

In obtaining power for the concept robot, a motor driven engine would introduce simplicity and cost-efficiency without removing productivity (Figure 3). Such engines can be a light weight model and less expensive than conventional combustion engines. The engine can be retrofitted for flex fuel, and thus reduces pollution output. A flex fuel engine uses special seals to allow the engine to work with various types of fuel including gasoline, diesel, and ethanol. An engine that would allow the use of different types of fuels and even their mixture would be more cost efficient for the farmer, which would allow for the choice of the cheapest fuel depending on the market.

In addition to concerns dealing with the strength and efficiency of the robot, certain geographical conditions must also be taken into consideration, such as steep slopes, muddy and rocky terrain, and weather conditions. Earth being a highly agriculturally diverse planet makes it difficult for the same robot to perform the functions it was made for in one terrain as in another. Nonetheless, mechatronics has already been put into application to overcome these challenges using robots like the RHex or BigDog. As innovations of Boston Dynamics, these animal-like robots can go over rocks, mud, sand, farmland, up steep slopes and stairs as well [6]. Using the model of the RHex on future concept agricultural robots, the robot would be more durable in various geographical locations and harsh environments. The structure of the robot allows it to move freely and easily, and its enclosed circuitry would make it waterproof to prevent any damage due to humidity and precipitation.

To introduce the simplicity of the world of mechatronics to farmers, the farmer will be given a supplied software and step-by step visual aids for the use of their own computer as a control station. In an included kit of parts will be a handbook and several interchangeable parts. The maintenance and installation process of both the software and the robot, and specification of all parts will be included in the kit, further stressing on simplicity.

With the above mentioned components of an agricultural robot of such kind that carries the technology that has been influencing this evolution of agriculture, we can prospect that it will drive our agriculture to this envisioned state of a “green” ecology. Furthermore, this drive will include the great elements of time effectiveness, accuracy, and efficiency.

The little-known field of mechatronics has slowly and progressively served as the bridge to bringing evolution to a new agriculture within its native elements of being green. This broad field of engineering opens new innovative ways of cultivating that allows farmers to enhance productivity without losing a grasp of time, accuracy, and productivity. Furthermore our concept of a “green” robot serves the purpose of helping and improving our evolution in our agriculture. In addition, we can say that a new door will be opened to the concept idea of farmers cultivating their own technology to become the architects of their own agriculture.

References:

- [1] Todd Rohde, Yaskawa. Yaskawa Electric America, Inc. 2009.
<<http://www.yaskawa.com/site/products.nsf/staticPagesNewWindow/mechatronics.html>>
- [2] Phelan, Benjamin. *How We Evolve. Seed Magazine.* 2008.
<http://seedmagazine.com/news/2008/10/how_we_evolve_1.php>.
- [3] Bellis, Mary. *History of American Agriculture.* 2009.
<<http://inventors.about.com/library/inventors/blfarm1.htm>>.
- [4] Bar-On, David. Hessel, Lior. *Self Contained Fully Automated Robotic Crop Production Facility.* 2002.
<<http://www.google.com/patents?hl=en&lr=&vid=USPATAPP10083343&id=04eCAAAAEBAJ%20%20%20%20%20%20&oi=fnd&dq=robotic+arms+that+cultivate+the+roots+of+plants+and+rotating+mechanisms+to+seed>>.
- [5] *Useful Plant: Bamboo: What's Bamboo?* <<http://www.mcyczm.com/sdp/430038/4/cp-2411880.html>>.
- [6] *RHex Devours Rough Terrain.* Boston Dynamics, 2009. <http://www.bostondynamics.com/robot_rhex.html>.

Tables and Figures:

Evolution of Agriculture and Technology

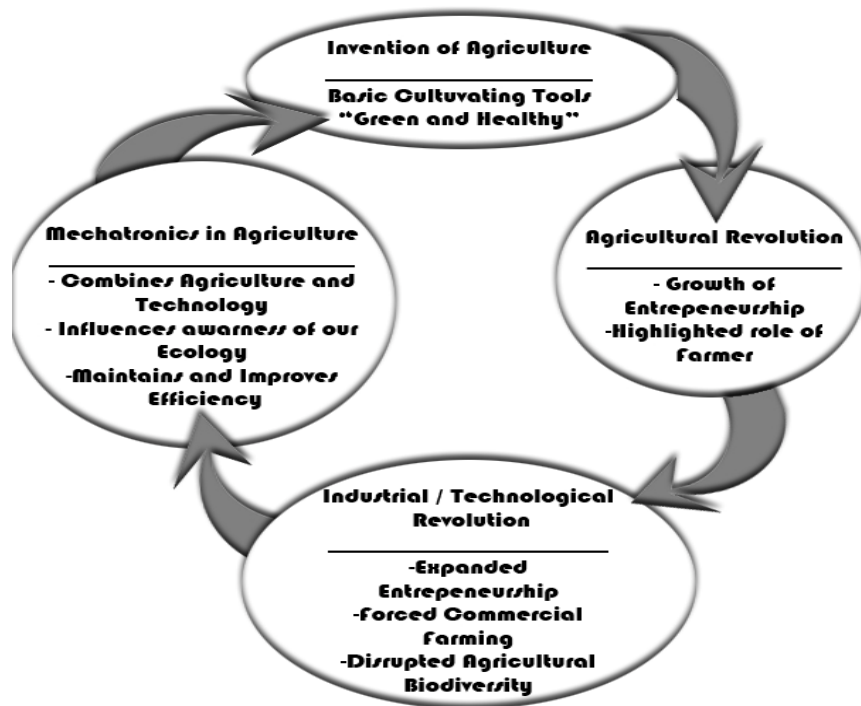

Figure 1: Evolution of Agriculture and Technology

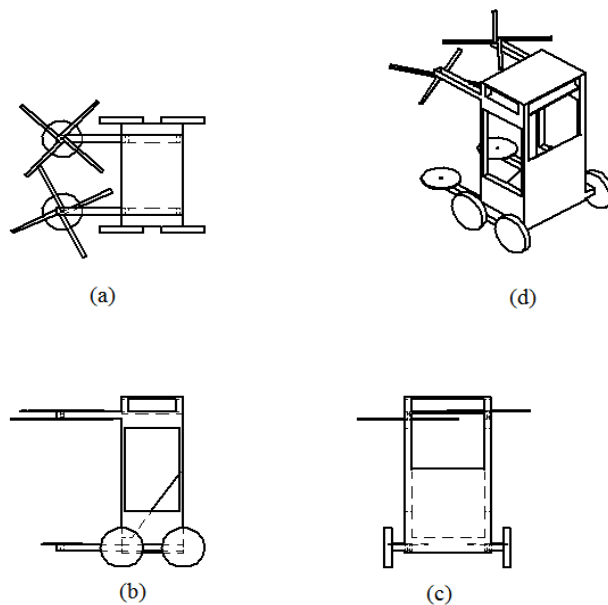

Figure 2: Orthographical views of concept robot (a) top view (b) right side view (c) front side view (d) complete view

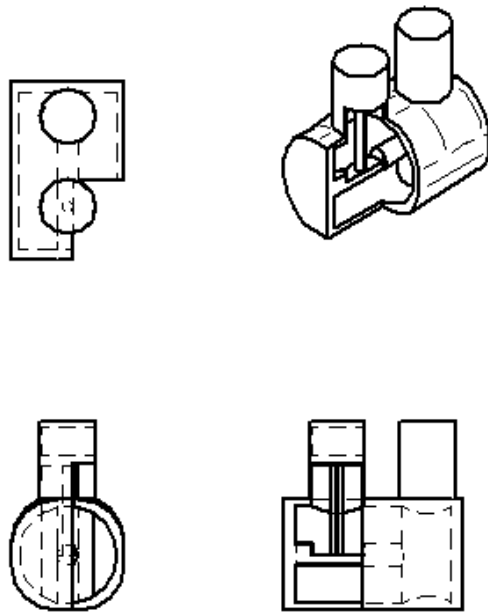

Figure 3: Orthographical view of motor driven engine