AC 2011-2038: AN ACTIVE LEARNING ENVIRONMENT FOR ENRICHING MATHEMATICAL, CONCEPTUAL, AND PROBLEM-SOLVING COMPETENCIES

Morris M. Girgis, Central State University

Morris Girgis is a professor at Central State University. He teaches undergraduate courses in manufacturing engineering. He received his Ph.D. in mechanical engineering from Hannover University, Germany. His current research in engineering education focuses on developing and implementing new educational tools and approaches to enhance teaching, learning, and assessment at the course and curriculum levels.

An Active Learning Environment for Enriching Mathematical, Conceptual and Problem-Solving Competencies

Abstract

Class projects involving problem-solving case studies are an effective way to develop and implement an active learning environment. A term class project was initiated as part of a Strength of Materials course. The project included the creation of a laboratory setup and session, lecture sessions, tests, problem-solving case studies, presentations, and reports. Active learning projects that engage students in structured course activities benefit students more than traditional lecture-based approach because students learn to construct their own version of knowledge and skills. The project was designed to provide a scaffolding mechanism to accommodate academic diversity within students by choosing the appropriate problem level that matched individual students' skills. The premise of this project was that the domain conceptual knowledge as well as mathematical manipulation skills would be improved by working on project-based problem-solving tasks. This research attempts to explore a new pedagogical approach and gain experience in implementing this active learning project. The project was assessed through pre- and post-tests that were given to evaluate the effectiveness of the learning approach. Questionnaires and interviews provided positive feedback from students who were actively engaged in the project. Although quantitative results are not fully available, several valuable lessons were learned. Follow-up research will investigate the issue of transferability of problem-solving competencies, together with other cognitive skills, across other domains of the engineering curriculum.

I. Introduction

Many engineering professors teach courses through deductive, or lecture-based, instruction. One drawback of this approach is that students become passive recipients of knowledge, rather than actively learning. Generally, engineering students have some difficulties with understanding concepts, applying mathematics and science, or solving problems. Even though professors do their best to explain difficult problems and the underlying conceptual knowledge, students may not advance in problem-solving, and oftentimes struggle with conceptual understanding. Traditional instruction falls short in providing students with the tools and skills needed to utilize the lecture knowledge and information in systematic problem-solving activities. It is evident that engineering instructors need additional innovative educational tools and strategies to enable students to advance in their conceptual and procedural knowledge and skills.

The scope of this paper is the development of an active learning approach involving problem-solving case studies. This paper focuses on the development of a set of engineering mechanics problems, and investigates their suitability for theoretical and experimental studies in an undergraduate course. The work is further extended to an integrated teaching approach involving lectures, testing, laboratory projects, and case studies.

In this paper, a comprehensive project for developing mathematical, conceptual, and problem-solving competencies has been developed. Two engineering mechanics problems consisting of springs, pulleys and/or a beam will be presented. One problem was chosen for implementation in

a Strength of Materials course project. The features of the spring-pulley-beam system will be discussed and specific domain concepts will be presented. A conceptual analysis was performed to develop sub-problems of the main project problem to enable scaffolding on problem solving during the project. Three appendices include the project handout, the solution equations of the problem and the post-test of the project. Finally, project findings and conclusions will be reported.

II. Literature Review on Active Learning

In the literature for educational research, some review publications such as Prince¹ and Prince & Felder² examined active learning. Relevant terms are used to describe different instructional methods of active learning and efforts were made to precisely characterize them and provide universally accepted definitions. Different styles of active learning include collaborative learning, cooperative learning, problem-based learning, project-based learning, case-based learning, discovery learning, and just-in-time teaching. Regardless of the chosen name for the teaching and learning activity, they all fall under the umbrella of active learning and inductive teaching and learning.

As opposed to traditional lecture-based instruction, these methods actively engage students in the educational process. These instructional methods invite students to become engaged, and therefore responsible for their own learning. Additionally, these methods can be characterized as constructivist methods², in which students construct their own versions of knowledge rather than simply receiving versions presented by their teachers. The methods almost always involve students discussing questions and solving problems in class by active learning, and much of the work both in and out of class is done by students in groups (collaborative or cooperative learning). Previous work indicates there is strong agreement that active learning through problem-based learning, case studies, and project-based learning, is more effective than the lecture-based deductive approach. For example, Smith, Sheppard, Johnson, and Johnson³ studied pedagogies of engagement as related to class-based practices. They define Problem Based Learning (PBL) as learning that results from the process of working toward the understanding or resolution of a problem. The problem is encountered first in the learning process. Barrows⁴ cites six main features of PBL: learning is student-centered; learning occurs in small student groups; teachers are facilitators or guides; problems are the organizing focus and stimulus for learning; problems are the vehicle for the development of clinical problem-solving skills; and new information is acquired through self-directed learning.

While these inductive instructional methods lead to positive educational gains, confusion exists in interpreting their names and terms. For example, problem-based learning usually refers to ill-structured real-world problems. This may be confused with open-ended in-class academic problems. The same difficulty applies to case studies that commonly utilize real-life situations and cases. The author uses the term “active learning project” instead of using PBL to avoid such confusion with the established literature terminology. However, the term “case study” was also used as an alternative name for the project learning activity (see Appendix A). The term “case study” is justified, because the activity involves the systematic study of the case covering a group of engineering mechanics problems.

One of the challenges instructors face within university settings is the academic diversity found in any group of students. Taraban, et al.⁵ identify critical differences between experts and novices in terms of conceptual knowledge and procedural skill by examining how individuals approach and solve discrete problems. It is less clear how students can develop from novices to experts through engagement with the learning resources in their training programs. In dealing with the academic diversity issue, this research presents a scaffolding learning approach that enables the student's gradual growth in learning the problem-solving process. In a recently published work⁶, a problem-solving inventory with three cognitive levels was developed to provide an instructional tool to enable such gradual growth in problem-solving skills.

Mills and Treagust⁷ discuss the pedagogy of problem-based and project-based learning among active learning approaches. They report that the use of project-based learning as a major part of the curriculum is new to engineering; while the use of "assignment projects" or "project assisted learning" is long-standing but poorly evaluated. In our case, the project-based approach to enrich problem-solving is new since the students are directed toward solving a problem or collection of problems that was otherwise assigned in a homework assignment.

Dym et al.⁸ discuss that PBL is best explained by the example of the Denmark's Aalborg University model, which was initially founded on "problem-oriented, project-organized education." Aalborg University offered engineering as multidisciplinary education, and divided it into two main themes: i) design-oriented project-organized education dealing with "know how," or the practical problems of constructing and designing on the basis of a synthesis of knowledge from many disciplines; ii) problem-oriented project-organized education dealing with "know why," or the solution of theoretical problems through the use of any relevant knowledge regardless of which discipline the knowledge is derived.^{9,10} The research reported in this paper attempts to implement problem-oriented project-organized education through solving academic problems in a specific domain within a structured project. It is hoped that the gained knowledge and skills will be retained and transferred to other domains throughout the curriculum.

III. Research Approach

A. Research Questions

This research explored the effects of active learning instruction on students' conceptual understanding, mathematical manipulation ability, and their skills of utilizing the engineering concepts and mathematics to solve problem scenarios. Specifically, our research attempted to answer two questions. The first question asked how effective the scaffolding approach is for teaching problem-solving while simultaneously addressing academic diversity. The second question focused on how this approach could best be implemented in project-based instruction.

B. Project Tasks

Table 1 explains the problem-solving related tasks, gained knowledge or skill, and the appropriate engineering taxonomic units or taxa. These taxa⁶ are identified as follows:

- I. Pre-knowledge Conceptual Experiences
- II. Basic Conceptual Knowledge

- III. Applied Conceptual knowledge
- IV. Procedural Knowledge
- V. Advanced Knowledge & Analytical Skills
- VI. Project-Based Knowledge
- VII. Professional Engineering Knowledge and Practices

Problem-Solving Task	Gained Knowledge or Skill	Taxonomic Unit(s) (Taxa)
<ul style="list-style-type: none"> • Reading and understanding problem statement • Identifying relevant concepts 	<ul style="list-style-type: none"> • Knowledge and understanding of basic concepts 	I, II & III
<ul style="list-style-type: none"> • Selecting engineering and mathematical symbols for system variables and coordinates 	<ul style="list-style-type: none"> • Applying basic mathematical and domain knowledge 	I & II
<ul style="list-style-type: none"> • Applying concepts and generating mathematical relations • Ordering and numbering equations as well as identifying independent and redundant equations 	<ul style="list-style-type: none"> • Applying conceptual and mathematical knowledge 	I, II & III
<ul style="list-style-type: none"> • Planning the process and outline for solving the problem • Solving for targeted variables 	<ul style="list-style-type: none"> • Applying conceptual knowledge • Problem-solving knowledge • Advanced knowledge and analytical skills 	III, IV & V
<ul style="list-style-type: none"> • Designing , manufacturing and assembling the physical model 	<ul style="list-style-type: none"> • Junior engineering major level • Project-based knowledge and project management skills 	V
<ul style="list-style-type: none"> • Conducting laboratory experiment 	<ul style="list-style-type: none"> • Hands-on laboratory experiences 	I & III
<ul style="list-style-type: none"> • Preparing and studying for a post-test 	<ul style="list-style-type: none"> • Solving multi-concept engineering problems 	III & IV
<ul style="list-style-type: none"> • Preparing presentation and report 	<ul style="list-style-type: none"> • Documenting & creating presentations & reports 	VI

Table 1. Project tasks, relevant knowledge, and taxonomic units

C. Conceptual Analysis and Problem Sub-structuring

Conceptual analysis is a method that studies a complex problem and determines its basic concepts. By reducing the structure or mechanism and eliminating some of its components, the number of concepts is reduced. Thus, the level of problem-solving complexity decreases. The advantage of this approach is the flexibility of choosing the level of problem difficulty that suits

the individual student's cognitive level. Therefore it is considered a powerful scaffolding tool for dealing with the academic diversity within the same group of students.

Problem Statement Required are the beam tip or bar displacement and the system spring stiffness located at load location.				
Concept/ Confusing Concept/ Skill	Taxonomy Level: [I]	Taxonomy Level: [II]	Taxonomy Level: [II]	Taxonomy Level: [III]
1. Hooke's law	✓	✓	✓	✓
2. Rigid bar – deflection is governed by geometry	✓	✓	—	✓
3. Beam static equilibrium	✓	✓	—	✓
4. Free-body diagram for the beam	✓	✓	✓	✓
5. Pulley concept	—	—	✓	✓
6. Free-body diagram for the pulley	—	—	✓	✓
7. Hidden concept: cord moves with pulley rotation	—	—	✓	✓
8. Confusing concept: springs k_1 & k_2 appear to be in parallel	—	✓	—	✓
9. Confusing concept: spring deflection confuses with end displacement	—	—	✓	✓
10. Skill: algebraic manipulation skill	—	✓	✓	✓
Number of relevant concepts	4	6	7	10

Table 2. Scaffolding Approach with Different Taxonomy Levels [I], [II] & [III]

D. Strategy for Problem-Solving

In this project, a comprehensive strategy to problem-solving was implemented to guide students working on the project. The steps are described in Table 3.

Project Step	Description	Objectives
1. Pre-test and Questionnaire	The students are given a pre-test to assess their initial level before the project. A questionnaire was given immediately after the pre-test to receive students' feedback and reflection on the pre-test and initial knowledge and skills.	Assessing student initial knowledge and problem-solving skills.
2. Review and Lecture Session	Explain the concepts needed for problem-solving. The lecture is based on the pre-test results and students' feedback.	Preparing students and keeping them motivated
3. Laboratory Session	Assemble and measure one-spring-beam under loading to experimentally determine system behavior and compare results with estimated analytical values.	Engaging students in hands-on activity
4. Preparatory Problems	Students work on simple problems similar to problems of Table 4, ref. ⁶ . This strategy has proven very effective in gradually engaging the student in learning the concepts and enforcing the problem-solving skills.	Scaffolding and gradual knowledge growth
5. Review and Lecture session	Explain the concepts needed for problem-solving. The lecture provides critical concepts and problem-solving hints to prepare the students for the upcoming quiz and post-test and encourage students to work on the project tasks.	Maintaining momentum
6. Take Home Quiz	A two questions quiz at an intermediate level of difficulty to challenge students and push them to review concepts and advance in problem-solving.	Learning opportunity and maintaining project momentum
7. Solving the Challenging Problem	Students are required to work on the analysis and derivation of system equations describing the assigned spring-pulley problem. Students are encouraged to seek help from the instructor as needed.	Long-term engaging in an active learning of problem-solving
8. Post-test	Assessment of the conceptual understanding and problem-solving skills. The test is a hybrid style of multi-choice and write-up questions.	Assessing learning outcomes
9. Oral Presentation and Final Report	At the end of the project, students present their findings to their peers and submit a written final report.	Assessing learning outcomes
10. Post-project Questionnaire	Get feedback and comments from the students on benefits and pitfalls of the project.	Assessing learning outcomes

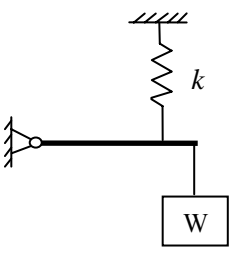
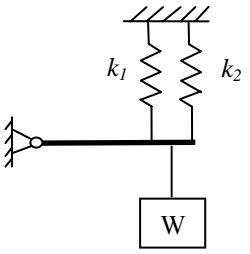
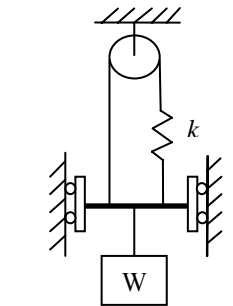
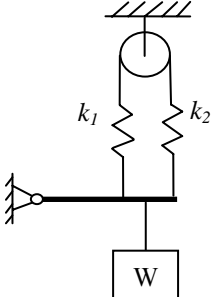
Table 3. Active Learning Project Outline

IV. Problem-Solving Case Studies

A. Description of Case Studies

Two different case studies consisting of springs, pulleys and/or a beam were considered for this study. In team projects, students were assigned one case study and were required to derive the governing equations of the mechanical systems and solve them. Derivation of mathematical equations was conducted for the assigned problem involving physical parameters with appropriate assumptions and constraints. Students completed a parametric study for the problem by varying the parameters and graphical results were plotted. Laboratory experimental modules were designed and constructed to enable changing or adjusting the model dimensional parameters. The modules were made available to students to assist in conducting the activity.

The first problem-solving system consists of one fixed pulley, two springs with different stiffness values, and a pivoted lightweight beam suspended by the springs and supported by a hinge at the other end of the pulley (Figure 1a). The second system (Figure 1b) consists of two pulleys and two springs with different stiffness values. One pulley is fixed, while another lightweight pulley moves freely up and down. The weight W is guided to maintain the vertical movement of the system. The pulley assembly system offers a mechanical advantage of “two.” The first system was selected for the problem-solving project (see Appendix A). The second system was used in class problems and in the post-test (see Appendix C).

Both systems involve numerous concepts and flexible mechanisms that possess both dynamic and animating features within the system. Deriving mathematical relations using known and unknown system variables strengthens students’ mathematical skills as well as their problem-solving skills. Although the algebraic skills required are simple, the process of deriving the case study equations greatly enhances the conceptual and procedural knowledge and in turn enables students to understand the nature of these systems and how they work.

The governing equations describing these systems are derived as function of a set of given parameters. Several assumptions and decisions or choices are required in order to advance to the final solution. The final system equations can be entered in an Excel program to determine the required system values under given conditions in tabular and graphical forms. The results are then analyzed to determine the range of useful parameters that can be used to generate reasonable practical laboratory models.

B. Features of the Spring-Pulley Systems

A mechanical system consisting of springs, pulleys and bars or beams can be used as a visualization tool for students in many engineering courses. It is appropriate for both introductory courses as well as more advanced physics, statics, and mechanics courses. The following are special features for spring-pulley systems:

- The system can be varied to cover both simple and difficult problem-solving levels. There is no limit for the level of problem difficulty. By adding more springs and pulleys, a composite system can include a high number of variables and equations, which increases the complexity of the system. For example, a system configuration similar to Figure 1b with two pulleys and two springs can have up to ten different configurations by changing the position of each

spring to any of the locations [1] to [5]. Using three springs will generate six different configurations, and so on.

- Visual demonstration can be very effective in explaining concepts and revealing hidden relationships among the system components. This “pre-knowledge” was considered the first taxonomic unit of the engineering taxonomy⁶. This taxon can also include laboratory demonstrations and simple experiments to demonstrate basic concepts.

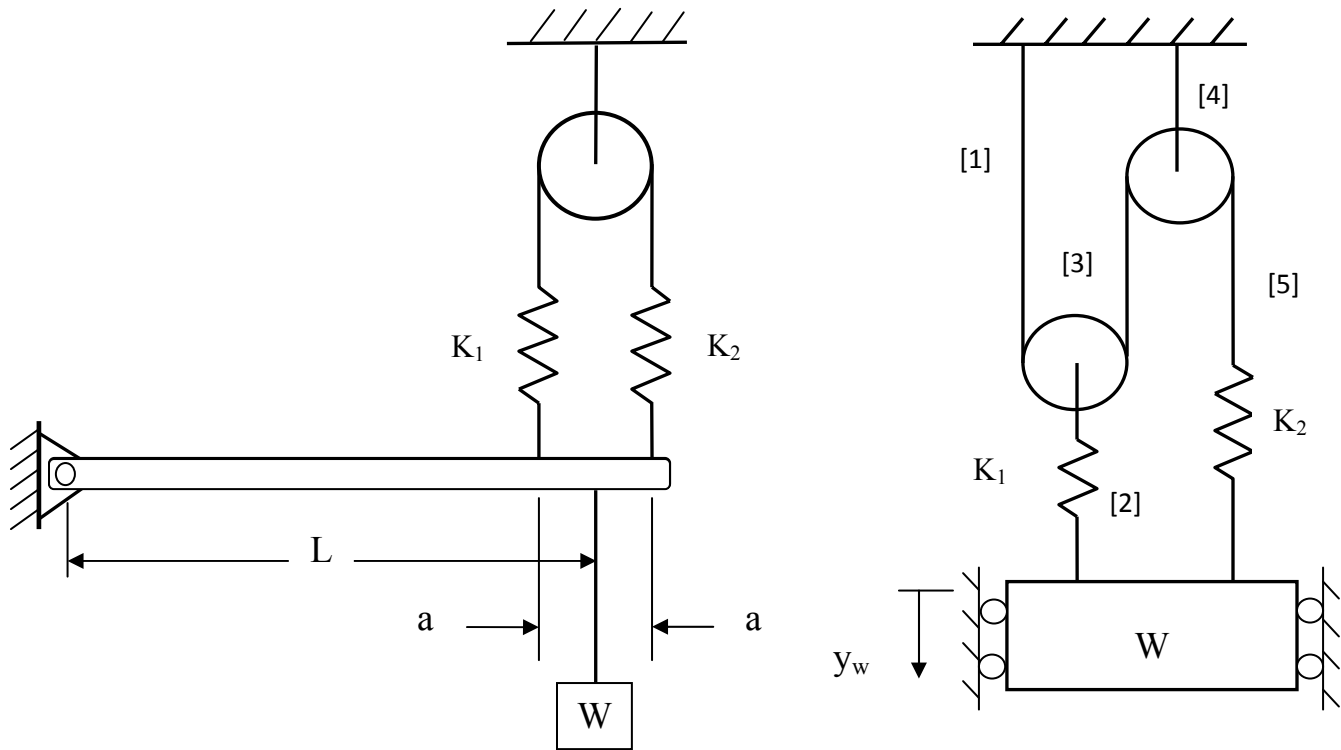

Figure 1 a) Case Study with Spring-Pulley Pivoted Beam Configuration

b) Case Study with Spring-Pulley Configuration

- Spring-pulley systems are excellent candidates for classroom demonstration at this pre-knowledge level.
- Spring-pulley systems require applications of concepts, including, but not limited to free-body diagrams, static analysis, Hooke’s law, algebraic and trigonometric concepts, and pulley movement concepts.
- The system can easily be assembled and built with low-cost components, and then used as a demonstration tool during lecture session.
- Many elastic metallic components and structures can be modeled as springs. Therefore, many machine design problems can be simplified to spring problems.

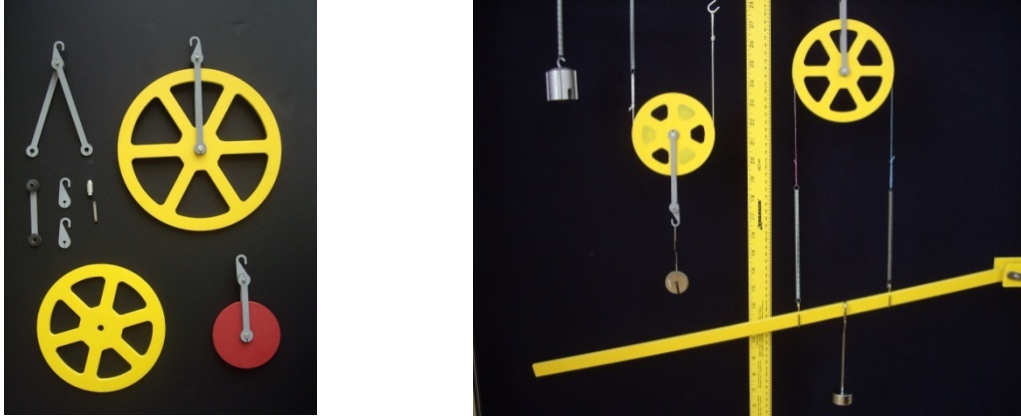

Figure 2. Manufactured pulley components and assembled configurations

C. Concepts and Assumptions

The following are the frequently used sets of key concepts and assumptions needed for solving the spring-pulley-beam problem. These were explained in lectures and other project sessions as needed.

Statics Concepts

- free-body diagram
- force equilibrium
- moment equilibrium

Spring Concepts

- Hooke's law
- spring deflection as the relative displacement of its nodes

Pulley Concepts

- frictionless pulley concept
- cord movement around pulleys
- fixed and movable pulley concepts

Rigid Beam Concepts

- triangular similarity involving spring node displacements

Assumptions Used During Problem-Solving

- elastic spring behavior (Hooke's law)

- weightless pulley
- frictionless pulley
- weightless beam
- rigid straight beam

V. Results from Students' Questionnaires

Comments and observations were made by participating students through questionnaires at the conclusion of the project. Lessons learned as well as challenges faced by students are reported below.

A. Lessons Learned

“I had the opportunity to reinforce previously learned engineering concepts and topics, such as: algebra, statics, Hooke’s law, free-body diagram, and geometric analysis.”

“I learned how pivotal time management is, especially to meet due dates.”

“Ability to efficiently diagnose problems using free-body diagrams”

“Application of concepts learned to solve engineering problems”

“Addressing complex situations by reducing them to simple sub-problems”

“The key to solving an engineering problem is in the understanding of the fundamental concepts required. So, when I struggled with the problem, I went back to review relevant concepts, then I tried again.”

“With the instructor’s guidance and encouragement, I was able to walk through the project steps and tasks.”

“The step-wise treatment of problem solving improved my skills in organizing the problem-solving steps, manipulating the variables and navigating through the equations of the problem. This was otherwise a frustrating task.”

“The project helped me perform better on the quiz and the final test.”

B. Challenges Faced

“Time, deriving system equations, recognizing what needed to be done and setting the details and ultimate goals of the project”

“The main challenge was the understanding and identifying the concepts. By working out the simple problems first, I was able to build up the conceptual understanding necessary for deriving the equations for the rigid bar displacement in the case study scenario.”

“My personal difficulty is the knowledge of breaking down the problem to its components and steps.”

“I have difficulty organizing the mathematical equations during solving the case study scenario, even though I solved the simpler problems within a reasonable time.”

VI. Concluding Remarks

This research effort has shown that the presented active learning environment can effectively help engineering students acquire conceptual, mathematical, and procedural skills. It also provides students with the needed awareness for problem-solving competencies throughout the curriculum. In particular, the project made the students aware that if they are to face difficulties in solving an engineering problem, there is generally a way to break it down to its sub-problems with less problem-solving steps. After gaining knowledge and confidence, students can then return to solving the complex problem.

Students commented that this project was beneficial in developing problem-solving as well as mathematical formulation and manipulation skills. The variety of problems offered the students an opportunity to gain deeper understanding of the domain's concepts by applying them repeatedly during the problem-solving process.

The manufactured laboratory model served as both demonstration and as a motivational tool helping students learn and reinforce the concepts throughout the project.

The issues students perceived to be negative about the project-based learning were the high time demands of the project and problems with team members who did not put their time and effort. However, students who recognized the benefits gained from the project were able to perform with a positive attitude.

As the first phase of developing and implementing this project-based approach, our efforts should be regarded in encouraging additional follow-up research. The overall impression of the effort indicates that the presented approach is timely and effective, especially for small classes or underrepresented groups. In general, it provides a practical problem-solving teaching strategy at academic levels where students are not prepared with enough conceptual knowledge and initial problem-solving skills, and are in need of scaffolding guided by the instructor to assure working on the appropriate problem level.

The scaffolding strategy for solving the problems with gradually increasing difficulty has proven to be very effective, because students gained confidence after solving problems in graduating difficulty. Additionally, introducing new concepts at a slower pace worked well for weaker students as they needed gradual learning to achieve progress in the project.

Future research should focus on investigating whether these procedural skills gained in the engineering mechanics domain can become transferable to other engineering domains, and how this transferability could be measured and assessed.

Acknowledgements

The author would like to thank Dr. Frank Schiraldi, Dean of Center for Academic Success, CSU for the valuable discussions and interactions during the development of this research. Thanks are due to Professor Tamra Ragland, Department of Professional Education, CSU for her constructive views and comments on the paper. Also, many thanks are extended to all my students who contributed to the success of this work through their hard work, suggestions and comments.

References

1. Prince, Michael, "Does Active Learning Work? A Review of the Research," *Journal of Engineering Education*, Vol. 93, No. 3, pp. 223-231, July 2004
2. Prince, Michael J., and Felder, Richard M., "Inductive Teaching and Learning Methods: Definitions, Comparisons, and Research Bases," *Journal of Engineering Education*, Vol. 95, No. 2, pp. 123-138, 2006
3. Smith, Karl A., Sheppard, Sheri D., Johnson, David W., and Johnson, Roger T., "Pedagogies of Engagement: Classroom-Based Practices," *Journal of Engineering Education*, Vol. 94, No. 1, pp. 87-101, January 2005
4. Barrows, H.S., "Problem-Based Learning in Medicine and Beyond: A Brief Overview," in Wilkerson, L. and Gijsselaers, W.H., eds., *New Directions for Teaching and Learning*, No. 68, 1996, pp. 3-11, San Francisco, Cal.: Jossey-Bass Publishers
5. Taraban, Roman, Anderson, Edward E., DeFinis, Alli, Brown, Ashlee G., Weigold, Arne, and, Sharma, M.P., "First Steps in Understanding Engineering Students' Growth of Conceptual and Procedural Knowledge in an Interactive Learning Context," *Journal of Engineering Education*, Vol. 96, No. 1, pp. 57-68, 2007
6. Girgis, Morris, "A New Engineering Taxonomy for Assessing Conceptual and Problem-solving Competencies," ASEE Annual Conference, AC 2010-1793, June 2010
7. Mills, J.E., and Treagust, D.F., "Engineering Education—Is Problem-Based or Project-Based Learning the Answer?" *Australian Journal of Engineering Education*, http://www.aace.com.au/journal/2003/mills_treagust03.pdf.
8. Dym, C., Agogino, A., Eris, O., Frey, D., and Leifer, L., "Engineering Design Thinking, Teaching, and learning," *Journal of Engineering Education*, Vol. 94, No. 1, 2005, pp. 103-120.
9. Kjersdam, F., and Enemark, S., "*The Aalborg Experiment: Project Innovation in University Education*," Aalborg, Denmark: Aalborg University Press, 1994. (Also available at auaw2.aua.auc.dk/fak-tekn/aalborg/engelsk.)
10. Luxhol, J.T., and Hansen, P.H.K., "Engineering Curriculum Reform at Aalborg," *Journal of Engineering Education*, Vol. 85, No. 3, 1996, pp. 83-84.

Appendix A – Case Study Project Handout

MFE 3530 – Strength of Materials

Fall 2010

Case Study Project

Project Objectives

The objectives of this project are

1. Work on the case study as a multi-task engineering project in a team work environment
2. Strengthen students mathematical skills needed for solving engineering problems
3. Enhance creativity and engineering knowledge in designing and manufacturing the system prototype
4. Improve communication skills and team work experience while working to solve the case study mystery, building the prototype, preparing the oral presentation and the final report

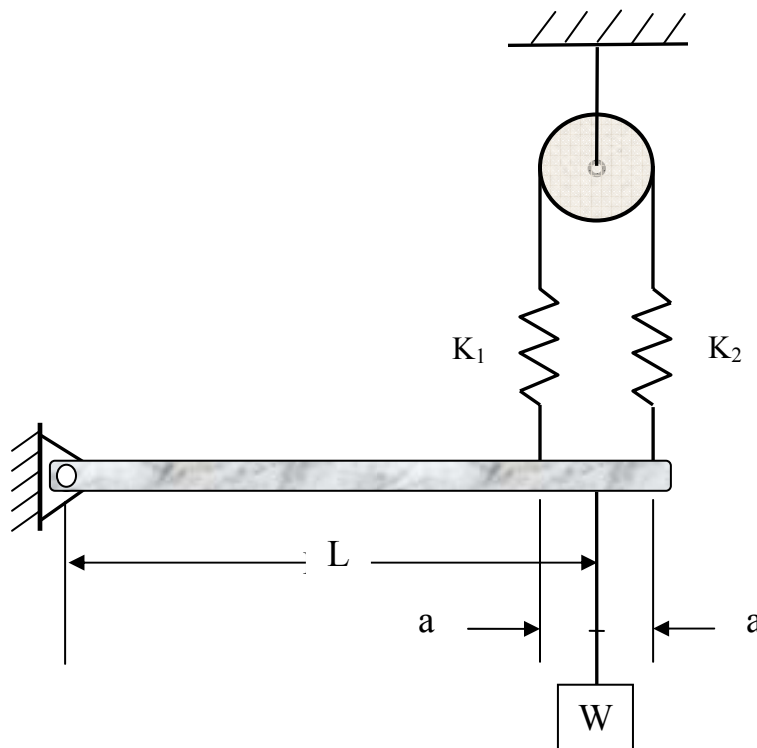

Spring-Pulley-Beam System

Problem Statement

Given is the pulley-spring system with the physical system parameters:

- Spring stiffness values K_1 & K_2
- Beam dimensions L & a
- Weight W

Upon release of the weight W , the horizontal beam will deflect and settles in static equilibrium. Derive the mathematical expressions for the beam tip displacement as a function of W , K_1 , K_2 , a & L . Derive an expression for the deflections of each spring δ_1 & δ_2 .

Draw free body diagrams as needed for force analysis.

After deriving the system equations, assume certain values of the beam dimensions, the weight and the spring stiffness. To simplify the case, assume that $K_1 = K_2$.

Case Study Approach

1. Prepare materials to build a prototype of the mechanical system with flexibility to enable quick change of the system dimensions
2. Draw the appropriate engineering drawings to manufacture the prototype according to specifications
3. Derive the system equations by choosing appropriate free-body diagrams, applying static analysis, Hooke's law, etc.
4. Keep a record of your work in a notebook or a folder with dates
5. Organize the tasks of the project and distribute them among the team members

Please, consult the instructor for help on any issue or difficulty

Deliverables

1. Power Point oral presentation
2. A formal final report to include all derived equations, assumptions and parameters, final numerical tables and plotted charts
3. Functioning laboratory model

Appendix B– Derivation of Equations for the Spring-Pulley-Beam System

The following describes the mathematical derivation for one of the possible solutions for the assigned project problem. This exercise enriches problem-solving skills, while it reinforces student’s conceptual understanding as well as mathematical manipulation ability.

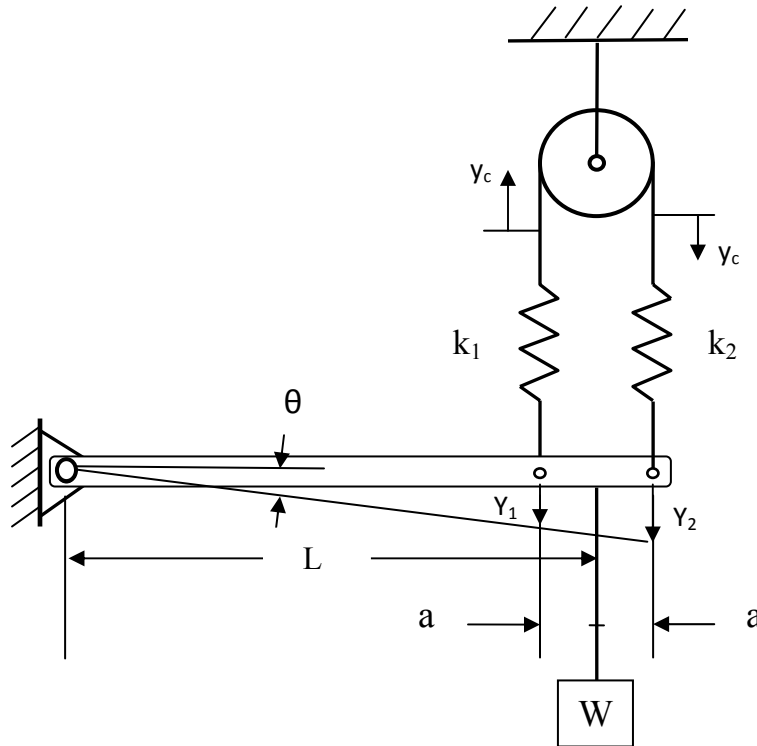

Problem Constants and Parameters

System constants are: W , k_1 , k_2 , L & a

System parameters are: y_c , y_1 , y_2 , δ_1 , δ_2 and θ

y_c is the cord displacement around the pulley,

δ_1 & δ_2 are the spring deflections for springs k_1 & k_2

System Mathematical Equations

$$\text{Triangular similarity for } y_1 \text{ \& } y_2: \quad y_1 / (L-a) = y_2 / (L + a) \quad (1)$$

$$\text{Spring deflections } \delta_1 \text{ \& } \delta_2: \quad \delta_1 = y_1 + y_c \quad (2)$$

$$\delta_2 = y_2 - y_c \quad (3)$$

Frictionless pulley / Hooke's law: $F_1 = F_2 \rightarrow k_1 \cdot \delta_1 = k_2 \cdot \delta_2$ (4)

Sub. (2) & (3) into (4) $\rightarrow k_1 (y_1 + y_c) = k_2 (y_2 - y_c)$ (5)

Static moment balance $\Sigma M_o = 0$ $F_1 (L - a) + F_2 (L + a) = W \cdot L$ (6)

Since $F_1 = F_2$, therefore, $F_1 = F_2 = W/2$ (7)

Using (4), (5) & (6) becomes $k_1 (y_1 + y_c) (L - a) + k_2 (y_2 - y_c) (L + a) = W \cdot L$ (6a)

Rewrite (1) $y_2 = y_1 (L + a) / (L - a)$ (1a)

(5) & (1a) $\rightarrow y_c = [k_2 \frac{(L+a)}{(L-a)} - k_1] \cdot y_1 / (k_1 + k_2)$ (8)

Introducing $\gamma = \frac{(L+a)}{(L-a)}$, (1a) becomes $y_2 = \gamma y_1$, and (8) becomes

$$y_c = [\gamma k_2 - k_1] \cdot y_1 / (k_1 + k_2) \quad (8a)$$

Expressions for y_1 y_2 are:

$$y_1 = \frac{(k_1 + k_2)}{(\gamma k_2 - k_1)} y_c \quad (9)$$

$$y_2 = \frac{\gamma(k_1 + k_2)}{(\gamma k_2 - k_1)} y_c \quad (10)$$

From (2) & (9): $\delta_1 = \frac{k_2 (1 + \gamma)}{(\gamma k_2 - k_1)} y_c$ (11)

From (3) & (10): $\delta_2 = \frac{k_1 (1 + \gamma)}{(\gamma k_2 - k_1)} y_c$ (12)

Since $F_1 = k_1 \delta_1 = W/2$, then $y_c = \frac{W(k_2 \gamma - k_1)}{2k_1 k_2 (\gamma + 1)}$ (13)

Substitute for y_c in (9) & (10) $y_1 = \frac{W(k_1 + k_2)}{2k_1 k_2 (\gamma + 1)}$ (14)

$$y_2 = \frac{\gamma W(k_1 + k_2)}{2k_1 k_2 (\gamma + 1)} \quad (15)$$

Angle of tilt $\theta = y_2 / (L + a)$ $\theta = \frac{W(k_1 + k_2)}{4k_1 k_2 \cdot L}$ (16)

Assuming values for W , k_1 , k_2 , a , and changing values for γ , one can calculate and plot the values for y_c , y_1 , y_2 , δ_1 , δ_2 and θ .

Appendix C - Post-test of Spring-Pulley Mechanics Concepts & Problem-Solving Competencies

Student Name _____

The questions are multi-choice. The right choice should be accompanied by an explanation answer. The multi-choice is weighed 50% of the score. The other 50% will be reserved to evaluate the explanation answer according to the following scoring system:

Conceptual & Problem-solving Competencies	Weight (%)	Q1	Q2	Q3	Q4	Q5
1. Identify problem key concepts through wording, formulae, laws, etc.	10					
2. Provide relevant concepts equations with units, symbols, etc.	10					
3. Apply concepts toward problem-solving	30					
4. Show a plan or an approach toward reaching a solution	30					
5. Arrive at final results and answers	20					
Total Score →						

1) In system # 1, the displacement of the bar, y_b , is

- $y_b = W/k$
- $y_b = W/2k$
- $y_b = W/4k$
- $y_b = 2W/k$

Show the steps of your work.

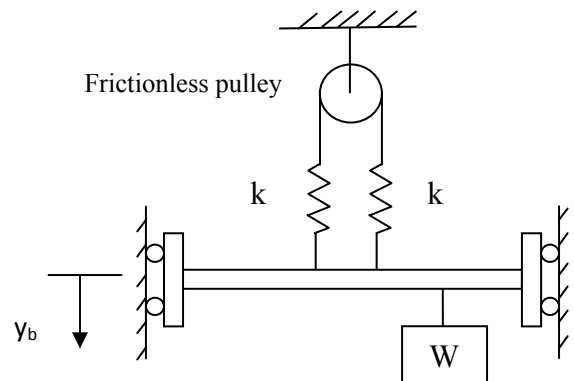

2) Upon release of the weight W in system # 2, the weight displacement y_w is

- $y_w = W/k$
- $y_w = 2W/k$
- $y_w = W/2k$
- $y_w = W/4k$

Show your work.

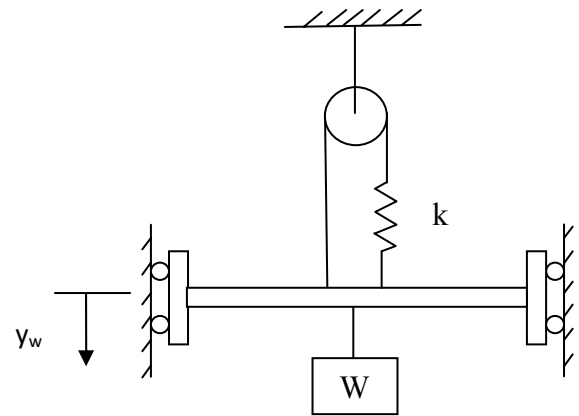

System # 2

3) The displacement of the weight, y_w , in system # 3 is

- $y_w = W/3k$
- $y_w = W/9k$
- $y_w = 2W/3k$
- $y_w = 3W/8k$
- $y_w = W/4k$

Show your work.

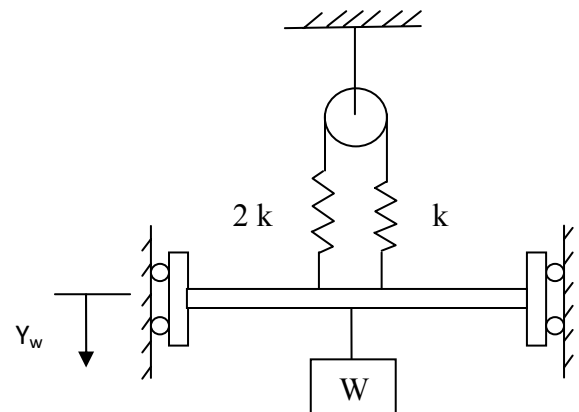

System # 3

4) In system # 4, the deflection of the spring (δ) is related to the weight displacement y_w :

- $\delta = 3y_w/2$
- $\delta = y_w/2$
- $\delta = y_w/4$
- $\delta = y_w$

Show your work.

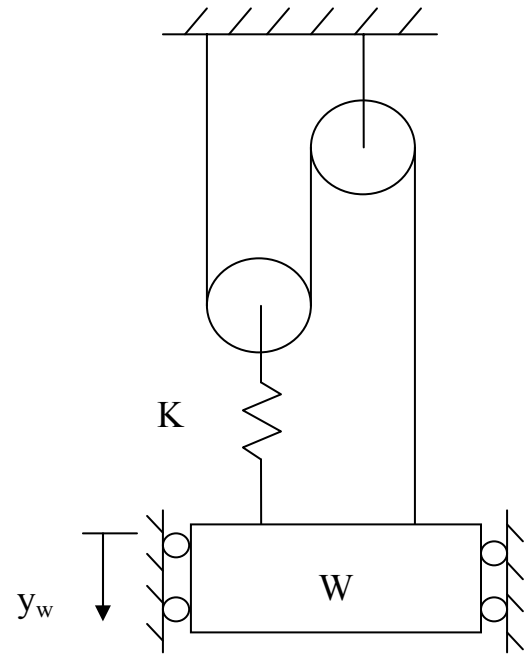

System # 4

5) The weight displacement y_w in system # 4 is

- $y_w = W/k$
- $y_w = W/3k$
- $y_w = 2W/9k$
- $y_w = 4W/9k$

Show your work.