

## **An Electrical Engineering Module for Women in Engineering**

**Sonia M. Bartolomei-Suárez  
Sandra Cruz Pol**

**College of Engineering  
University of Puerto Rico  
Mayagüez Campus**

### **Abstract**

The University of Puerto Rico Mayagüez (UPRM) hosts a summer camp called EXITE! (Exploring Interest in Technology and Engineering). This camp is designed to introduce girls from middle schools from the western area of Puerto Rico to the engineering and technological fields. The main objective of the camp is to motivate girls entering the 7<sup>th</sup> and 8<sup>th</sup> grades, early in their life, to select and pursue careers in engineering or computer sciences. The students participate on workshops applying scientific and engineering concepts, as well as on hands-on experiments in a laboratory environment.

One of the most popular workshops in EXITE! is the construction of an electronic doorbell for the girls' bedrooms. Girls at this age begin to ask for respect from their parents when they want to go into their rooms, and most of girls see the doorbell as the mean to manage this need. This motivates the participants to be interested in the workshop.

The construction of the electronic doorbell introduces the participants the basics concepts of electricity, circuits, types of materials and basic electrical equipment required to form a circuit like resistors, transistors, switches and diodes. During the workshop, the students learned to analyze and interpret simple electric circuits; also they learned to build an electric circuit. It is expected that the workshop will encourage young women to consider electrical engineering as career.

**Index Terms** – K - 12 programs, summer camps, team activities

### **Introduction**

EXITE! (Exploring Interest in Technology and Engineering) is a summer camp designed to introduce girls from middle schools to the engineering and technological fields. The main objective of the camp is to motivate girls early in their life to select and pursue careers in engineering or computer sciences. This is accomplished by exposing them to the engineering and computer sciences through a series of enhancing, unique and interactive activities.

This camp is sponsored by IBM Corporation, the Chancellor's Office and the College of Engineering at UPRM, and is held during a week in July. The camp is for a total of 20

Proceedings of the 2003 American Society for Engineering Education Annual Conference  
& Exposition Copyright © 2003, American Society for Engineering Education

students, all girls from elementary and middle schools of western area of Puerto Rico. The camp runs from 8:00 am to 5:30 pm. Most of the activities are held in the Industrial Engineering Building. The budget for the camp is around \$10,000.00.

During the week, the students participate in workshops applying scientific and engineering concepts and practices in laboratory environments. The workshops are designed to expose participants to engineering and computer sciences, and to provide participants better understanding about the concepts of working in teams, making hard engineering decisions, ethical behavior, and problem solving.

During these workshops activities, the students have the opportunity to share experiences with different professors, laboratory technicians, young professional engineers and scientists, and undergraduate and graduate students.

This paper presents an electrical engineering workshop that consists of the construction of an electronic doorbell for the girls' bedrooms. Girls at this age begin to ask for respect from their parents when they want to go into their rooms, and most of girls see the doorbell as the mean to manage this need. This motivates the participants to be interested in the workshop.

The goals of this workshop are:

- Introduce the students to the basics concepts of electricity, circuits, types of materials and basic electrical equipment required to form a circuit like resistors, transistors, switches and diodes.
- Teach students to analyze and interpret simple electric circuits.
- Teach students to build an electric circuit.
- Show the relationship between engineering and everyday products.
- Have each student leave with a product that they made, thus encouraging them to share their experience with their family.

### **Workshop overview**

The workshop can be completed in two hours. The materials required to build an electronic doorbell cost less than \$10 and can be easily obtained from an electronic store or over the internet. They are:

- resistors
- transistors
- buzzer
- light emitting diode
- switch
- breadboard
- wires

Two or three undergraduate students help the participants during the workshop and a faculty member teaches the basic concepts of electricity, and the role of engineers and

scientists in developing electronic components and products. During the workshop each participant has a workstation and the girls receive a handout that helps them through the workshop. Figure 1 shows a faculty member working with the students and Figure 2 shows a doorbell constructed by the participants. Next section presents the handout that the students receive during the workshop. This handout is written in Spanish but it was translated to English to be included in this paper.



Figure 1. Dr. Cruz Pol teaching the electronic basic concepts.

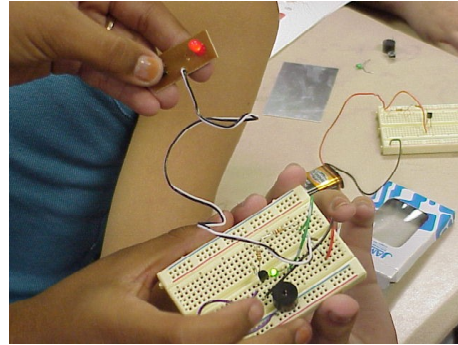

Figure 2. A doorbell constructed by a participant.

---

**Handout for the students (english version)**



**Electronic Doorbell**

Prepared by: Dr. Sandra Cruz Pol  
 Electrical and Computer Engineering Department  
 University of Puerto Rico Mayagüez Campus

**¿What is the electricity?**

It is the movement of small particles called electrons. Everything in the world is composed by microscopic particles called atoms. Inside the atoms there are these smaller particles called electrons. Thousands of millions of electrons are moved to create current.

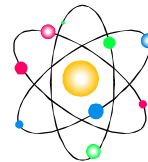

Figure 1. An atom.

### Electric Circuit.



The electricity has to travel inside a completed circuit, from the battery (V) to the element under electrical operation, as a light bulb or television.

This element is represented in the circuit with letter R, and means resistance. I refers to the current.

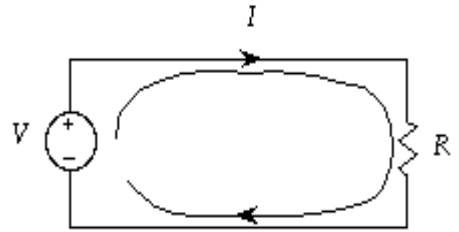

Figure 2. Simple Circuit .

### Conductor and Insulator Materials

The electricity flows easier by metal materials (copper, gold); such materials are called good conductors. In conductor materials, some electrons are so weakly attached to their atoms that they are essentially free to move about the whole volume of the material. Materials as the plastic, the rubber, and the ceramics conduce very few. These materials are known as insulators and they are used to cover the conductors as the copper wire that will be used to avoid receive current when is touched.

### Resistors

These components reduce or resist the electrons path. From there comes its name. This helps to control the amount of electricity traveling in the circuit. Without them some elements of the circuit will burn out. They are measure in ohms [W]. You will use two resistors with 220k $\Omega$  and 10k $\Omega$  values.

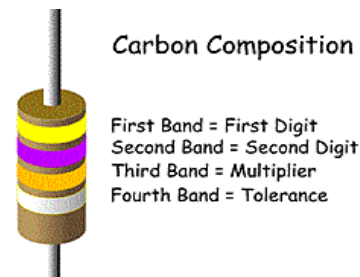

Figure 3. Resistor.

The resistors are made inside with carbon, a poor conductor. The value of a resistor depends in the carbon concentration inside. The resistors show color bands to identify their values. The values code is as shown in Table 1.

Table 1. Values codes for resistors.

Black	0	Green	5
Brown	1	Blue	6
Red	2	Violet	7
Orange	3	Gray	8
Yellow	4	White	9

The first two bands in a resistor refer to the first two numbers of the value of the resistor and the third band says how many zeros follow. For example: yellow-violet-orange = 4 7 y 3(three zeros) = 47000 = 47 kilo ohms.

The last band says how exact is the number, gold=  $\pm 5\%$  tolerance. This means that if a given value is  $100\Omega$ , it could be between  $95\Omega$  y  $105\Omega$ .

### Transistor

The transistor is made with materials known as semi-conductors. This material permits make small transistors, which permit build portable radios, computers, etc. The transistor has three feet. The middle foot is known as the Base. The other two feet are known as the Collector and the Emitter. (You will use a transistor type 2N2222).

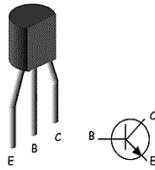

Figure 4. Transistor.

The transistor works as an electric valve, this means, it will let the current travels depending on the voltage in the middle foot (Base). When there is enough voltage in the Base, the current flows from the Collector to the Emitter.

### Buzzer

The metal and plastic disc is the buzzer. It produces a noise when the electricity travels trough the metal due to the tension and compression of it, building a sound wave in the air.

### Light Emitting Diode (LED)

The light emitting diodes (LED) are elements that look like small light bulbs but in reality are semiconductors that shine when an electric current flows in specific direction through them. In your doorbell circuit is it used to show the visitors that

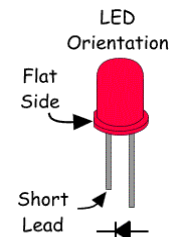

Figure 5. LED.

his/hers visit is being announced when arrived the room.  
The LEDs are used in a lot of electronic equipment including radios, video games, and calculators, among others.

### Switch

The switch open or connect the circuit to complete the circuit and allow the flow of electricity through the whole circuit.

### Breadboard

A breadboard will be used to connect the elements or components of the doorbell. It consists of a series of holes in where the elements are inserted. Some holes are connected internally to form nodes. Follow the diagram and you could paste the doorbell to your bedroom's door to know when you have visitors. ☺

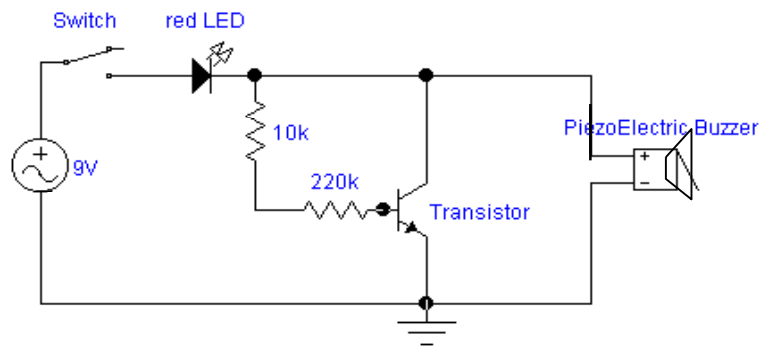

Figure 6. The Doorbell Electric Circuit.

Interested in finding out more about electricity and voltage?

[www.ece.uprm.edu/~pol](http://www.ece.uprm.edu/~pol)

[www.reprise.com/host/electricity/voltage\\_notes.asp](http://www.reprise.com/host/electricity/voltage_notes.asp)

## Conclusions

The results obtained for this workshop are shown in Table 1. These results show that the workshop was a success.

Table 1. Results of the participant's evaluations.

Activity		Adequacy of Topic		Instructor Effectiveness		Usefulness	
Number	Description	Average	Std. Dev.	Average	Std. Dev.	Average	Std. Dev.
9	Constructing a Doorbell	0.94	0.236	3.89	0.471	3.94	0.236

Looking at Table 1, it is concluded that the workshop on constructing a doorbell was one of the most popular. In scale from zero to one hundred, the adequacy of the topic was evaluated with a 94 % and the usefulness of it was evaluated with a 98.5 % (3.94/4.00).

Interviewing the participants after the workshop they said that through this workshop they realized that building electronic product was not difficult. They had a lot of fun constructing the doorbell and making it worked.

Through this workshop the objectives of:

- introduce participants to the basics concepts of electricity,
- teach participants to analyze and interpret simple electric circuits,
- teach participants to build an electric circuit,
- show them the relationship between engineering and everyday products, and
- have each of them leave with a product that they made, thus encouraging them to share their experience with their family

were fulfilled.

## References

Colombo, Luann, Buzz Off!, Paperback, October 2000.

## Biographical Information

### Sonia M. Bartolomei-Suárez

Sonia M. Bartolomei-Suárez is Associate Professor of the Industrial Engineering Department and Director of EXITE! Camp at UPRM. She obtained her PhD in Industrial Engineering from The Pennsylvania State University. Dr. Bartolomei-Suárez is an active consultant to manufacturing facilities in Puerto Rico, and specializes in facility planning and simulation. At UPRM, she works with the pre-college programs to introduce engineering to junior and high school students.

*Proceedings of the 2003 American Society for Engineering Education Annual Conference & Exposition Copyright © 2003, American Society for Engineering Education*

**Sandra Cruz-Pol**

Sandra Cruz-Pol is Associate Professor of the Electrical Engineering Department at UPRM. She obtained her Ph.D. in Electrical Engineering from the Pennsylvania State University. Her research interests are in the area of microwave remote sensing, specifically in the Microwave Atmospheric Absorption near the 22 GHz water vapor resonance line, and studies of the microwave sea surface brightness temperature seen from space over calm ocean. Dr. Cruz-Pol is currently working in various projects sponsored by NSF, NASA, IBM and IAP within the microwave remote sensing area including an Engineering Research Center (ERC) for Subsurface Sensing and Image Systems in collaboration with Northeastern University.