

An Exercise in High-School Engagement: Making a Demo Jammer for a Military Applications Course

Prof. Gene L. Harding, Purdue Polytechnic Institute

GENE L. HARDING is an associate professor of Electrical and Computer Engineering Technology at Purdue University, where he has taught since 2003. He has three years of industrial experience with Agilent Technologies, 28 years of combined active and reserve service in the United States Air Force, holds an MSEE from Rose-Hulman Institute of Technology, and is a licensed professional engineer.

Mr. Frank Joseph Rossi Jr., Trinity School at Greenlawn

A current high school junior, Frank Rossi attends Trinity School at Greenlawn, where he pursues a classical education. Outside of the classroom, Frank is also an avid athlete, taking part in both track and soccer. He resides in South Bend, Indiana.

Mr. Michael R. Holtz, Purdue Polytechnic Institute

MICHAEL R. HOLTZ is a Lab Technician at Purdue Polytechnic in South Bend Indiana where he has worked since 2008. He has over 22 years of working experience in the field of Electronic Technology with a strong background in Mechanical Technology as well. He also holds two Bachelor of Science degrees in Electronic Technology from Indiana State University and General Studies in Science and Math from Indiana University.

An Exercise in High-School Engagement: Making a Demo Jammer for a Military Applications Course

Abstract

One of the authors teaches an Electrical Engineering Technology course in Military RF Electronic Applications. In the lab portion of the course, students construct a mock radio controlled improvised explosive device (RCIED) using the radio from an old garage door opener, then spend the rest of the semester designing, building, testing, and demonstrating a jammer that uses radio frequency energy to defeat the mock RCIED. (It should be noted that it uses a beeper or buzzer in place of explosives.) The other authors are the site technician (and PCB layout guru) and a local high school student who was interested in learning more about both electronics and military applications.

The ultimate goal of the Jammer Project is to create a functional set of equipment that includes both a mock RCIED and jammer. They are planned to be used for demo purposes at high school recruiting activities.

This paper covers the first two phases of the Jammer Project: creating a mock RCIED and the circuit to control the jammer. It begins with a short description of the course in which the lab is taught, how the link to high school students came about, plus some background information on military applications and what the military terms “electronic warfare”. Then it describes the design and construction of both devices, followed by the student’s thoughts on his experience with the project. The last two sections describe parts of the project that are yet to come, the radio frequency amplifier and antenna, along with some lessons learned.

Background

The course that led to this project is Military RF Electronic Applications. It consists of an introduction to antennas and radio frequency (RF) wave propagation, an overview of military and civilian systems that use wireless communication techniques with a particular focus on radar, and a study of some techniques for emitter location and identification [1]. The basis of the course is what the military calls electronic warfare (EW), which can be defined as “the art and science of preserving the use of the electromagnetic spectrum for friendly use while denying its use to the enemy.” [2]

In the lab portion of the course, students first design and construct a mock radio-controlled improvised explosive device (RCIED), using a beeper or buzzer in place of explosives. Each team analyzes and dismantles an old garage door opener, then uses the radio receiver as the basis for their mock RCIED. They spend the rest of the semester designing, building, and testing what the military calls a jammer, which is a device that emits RF energy of the right type to prevent the mock RCIED from functioning. Along the way the students construct and study antennas, characterize RF propagation and propagation loss, do benchtop testing in the lab, and do “open range” testing in a large open parking lot adjacent to a nearby river.

The final lab in the course consists of a set of open-range tests in which the students quantify each jammer's effectiveness against each of the mock RCIEDs.

The professor who teaches this course also does periodic visits to local high schools to speak to students about engineering and technology careers. At some point, he got the idea to use a mock RCIED and jammer as a fun demo for the high school students to hopefully spark interest in technical careers and aid in recruiting. His original plan was to use a mock RCIED and jammer built by his students, but the next time the course was offered there were no jammers created that were effective enough to use for demonstration purposes. His daughter was attending a local high school that worked to get their students involved in research activities with local universities, so he offered to do the Jammer Project with some of their students as a summer project.

The goal of the Jammer Project was to create a mock RCIED and jammer that could be used for demo purposes. The basic project was the same: create a mock RCIED from an old garage door opener, and design and build a jammer to render it ineffective. The differences were twofold: first, there was a lot more oversight and guidance since the students, although very sharp, were still in high school; second, there were no labs to do things like study RF propagation. Any associated topics were explained verbally, sometimes with "chalk talks" on the whiteboard and/or equipment demos in the lab.

The mock RCIED has two primary components. The first is the mock RCIED itself, which contains the radio extracted from the garage door opener, plus the battery power supply and buzzer added by the student. The second part is the handheld remote, which can be used as-is with no modifications. A block diagram of the RCIED system is shown in Figure 1.

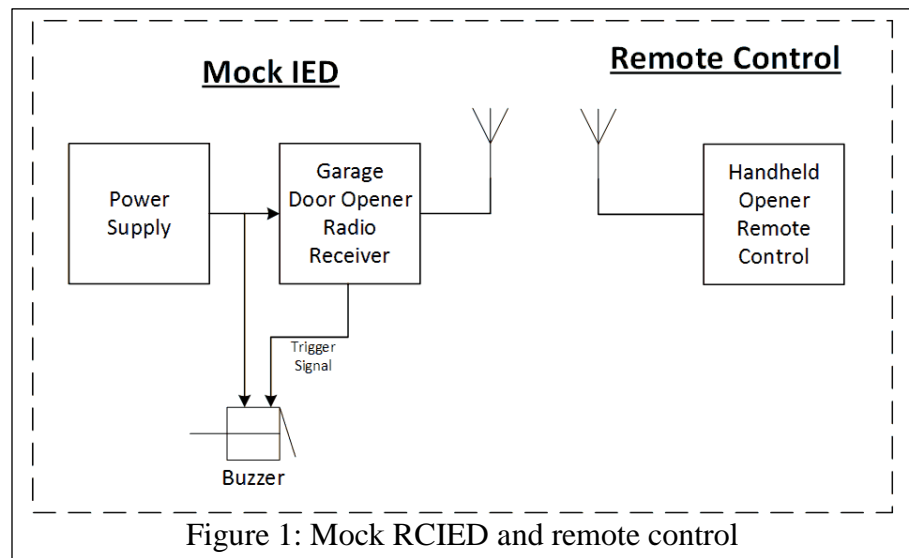

The jammer is comprised of a controller, which modifies jamming output in response to user controls; an RF amplifier that generates the signals for transmission; an antenna to radiate the signals; and a power supply. A block diagram of the jammer is shown in Figure 2.

The next two sections provide a detailed description of the mock RCIED and jammer controller, followed by the student's perspective of the experience, a brief description of the project portions yet to be completed, and the professor's comments on lessons learned so far.

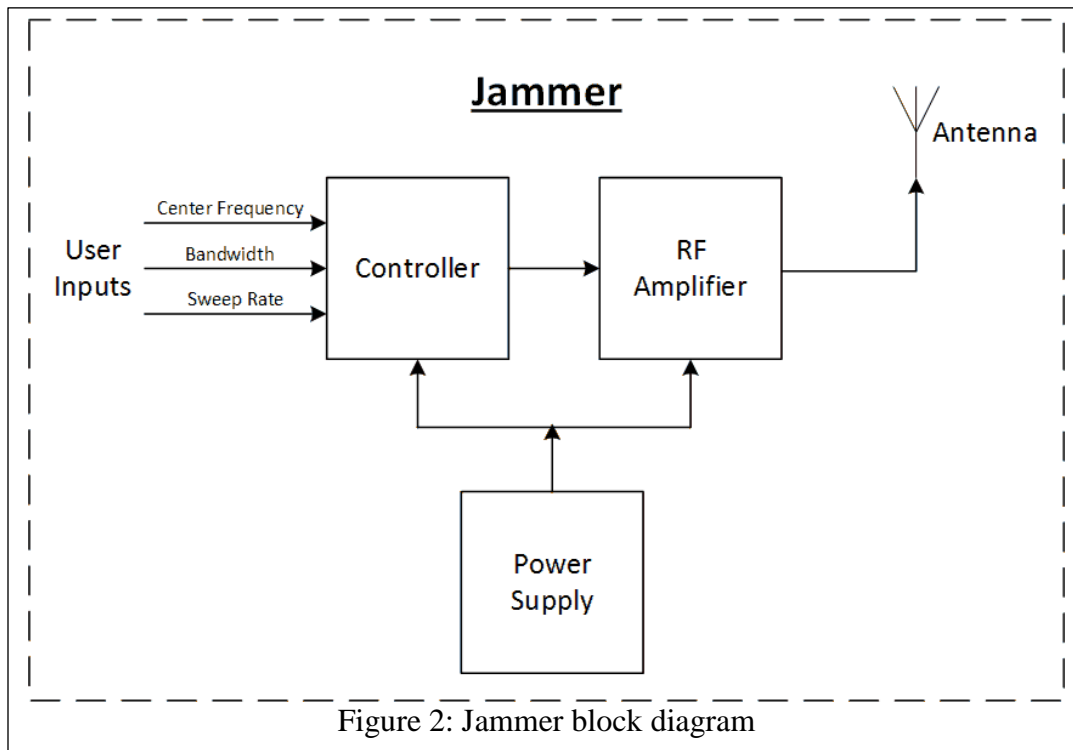

Project Part 1: Mock RCIED

The first part of the Project is similar to an activity the military calls foreign materiel exploitation (FME), which can be defined as the analysis of an unfamiliar adversary system to determine how it works, usually for the purpose of revealing any weaknesses that can be exploited in combat. In this case, the first lab involves analysis of an old garage door opener to locate its radio and determine what will be needed to extract it from the opener for independent operation. Students must trace through the power supply circuit to find a suitable point for injecting DC (battery) power, normally somewhere after the rectifier circuitry. They also must determine their opener’s power draw, frequency of operation, and an acceptable output to be used as a trigger to operate the beeper or buzzer.

The garage door opener used to create the mock RCIED is shown in Figure 3. Since the goal of Lab 1 is to emulate an FME, no effort was made to track down manufacturer information on the opener. A close-up of the printed circuit board (PCB) containing the radio circuitry is shown in Figure 4. This board uses a traditional linear power supply to convert AC line power to a DC voltage suitable for the electronics. Recognizable features include the transformer, rectifier diodes, and filter capacitor visible at the lower right of Figure 4. The filtered output is often a handy place to tap into the circuit

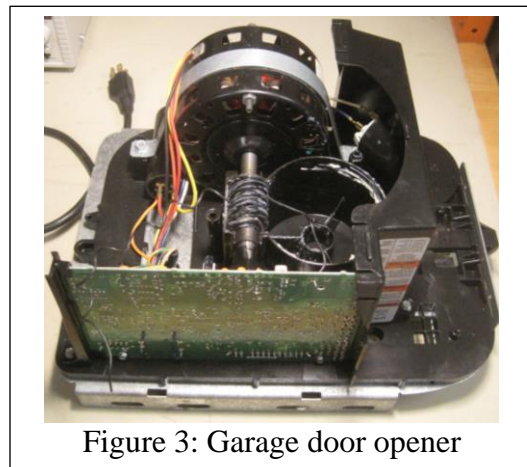

with battery power because it takes advantage of the voltage regulator circuitry already present on the PCB.

This board's radio and control circuits run off of 12 V and 5 V. Normal dropout voltage for a voltage regulator is 2 V, so a battery supply of 14 V or higher should work. The student working on the mock RCIED design found a series-18650 3.7-V battery by Dulex at a good price, so a four-pack of those batteries makes up the DC supply. The battery pack and its connection to the PCB are shown in Figure 5.

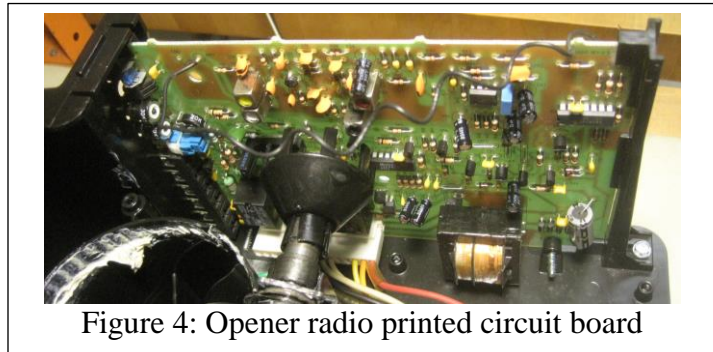

The power switch is a waterproof lighted rocker switch made by CW Industries [3]. As shown in Figure 6, the switch is mounted in the lid of the case, which is from Bud Industries [4].

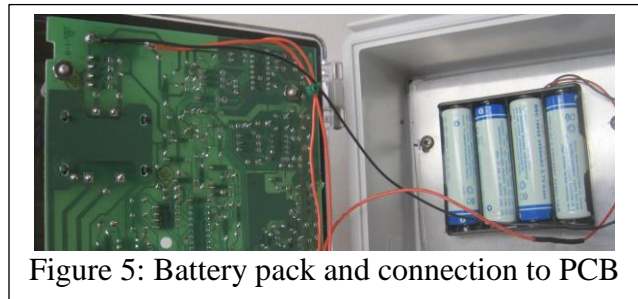

The operating frequencies of the remote control transmitter, as measured by an Agilent model N9340B spectrum analyzer [5], are 315 and 390 MHz.

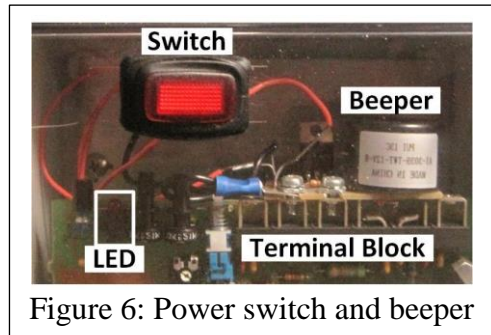

The last part of the design was the beeper circuit. The beeper, from PUI Audio, is rated for a minimum of 100 dB_{spl} [6]. Its loudness is important because it is enclosed in a sealed plastic box, so it must be loud enough to be heard clearly through the enclosure. There was an LED already on the opener PCB that had a 5-V signal suitable for a trigger. The trigger was routed to an IRF3709 MOSFET switch, which provides power to drive the beeper, as shown in Figure 7. The opener PCB also had a convenient terminal block on one end, which was adjacent to the trigger LED and provided a solid physical mount for the beeper circuit PCB.

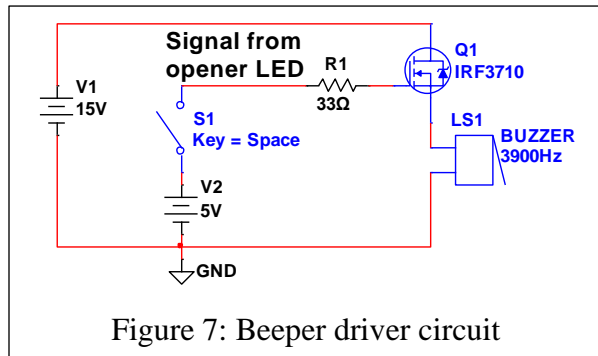

The final mock RCIED is illustrated in Figure 8.

Project Part 2: Jammer Controller

Before describing the controller design, it is important to understand the requirement it must meet. The garage door frequency band extends from 300-400 MHz [7], so without a priori knowledge of a specific garage door opener, the jammer must cover the entire frequency band. (In the course offerings so far, Professor Harding has seen opener remotes with frequencies as low as 303 MHz and as high as 390 MHz.) The approach of this design is to sweep the transmitter frequency from just below 300 MHz to just above 400 MHz, continuously repeating to prevent successful transmission of signals in the opener band.

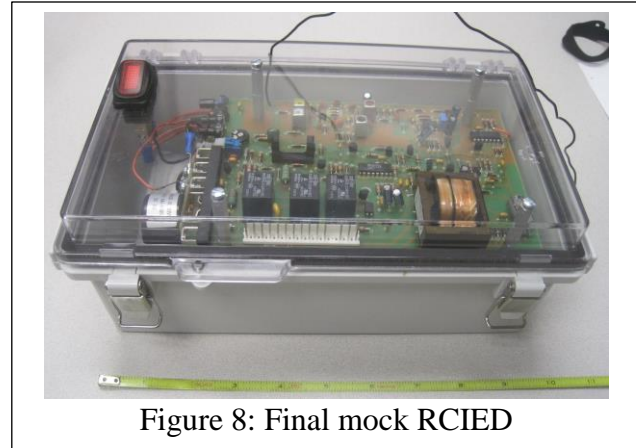

Figure 8: Final mock RCIED

A voltage controlled oscillator (VCO) creates the frequencies to be amplified for RF transmission. The VCO chosen for this jammer is the Crystek model CVCO55CW-0250-0450, which can generate frequencies from 250-450 MHz [8]. The tuning curve shown in the datasheet indicates that a voltage sweep from about 1.5-3.4 V should generate frequencies to cover the 300-400 MHz band. A sawtooth waveform, as shown in Figure 9, works well to drive the VCO. The repeating linear rise of the sawtooth ensures the same dwell time for all in-band frequencies.

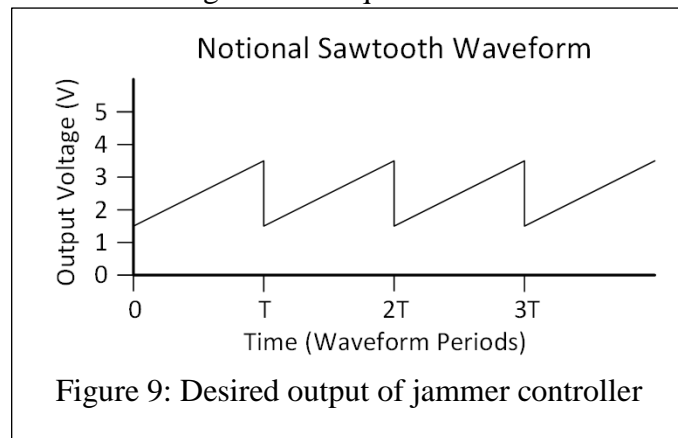

Figure 9: Desired output of jammer controller

The controller circuit uses three op amps to implement a sawtooth waveform with variable sweep rate, voltage span, and center frequency. The op amps are configured as a modified integrator, a comparator, and an inverting summer [9].

These op amps are U9A, U9B, and U9C, respectively, in the Multisim [10] schematic shown in Figure 10.

Several modifications were made to the standard circuitry to enable variable control. A classical integrator provides a triangle wave output when fed with a rectangular wave from a comparator, so the input was modified to have two separate branches. The “normal” branch routes through potentiometer R82 and fixed resistor R83 to charge capacitor C9, creating the ramp portion of the sawtooth wave. The branch through diode D6 and fixed resistor R81 allows the capacitor to discharge much more rapidly in the other direction, which forms the (almost) vertical portion of the sawtooth. A third branch was also added to enable extremely slow sweeps. This branch, containing the 50-M Ω resistor R91, is activated when the switch is opened. The 2-M Ω potentiometer, R82, provides a wide range of sweep rates, from a low of 225 Hz to a high of 9 kHz (as measured in lab tests). The 50-M Ω branch provides for a minimum sweep rate of 9 Hz.

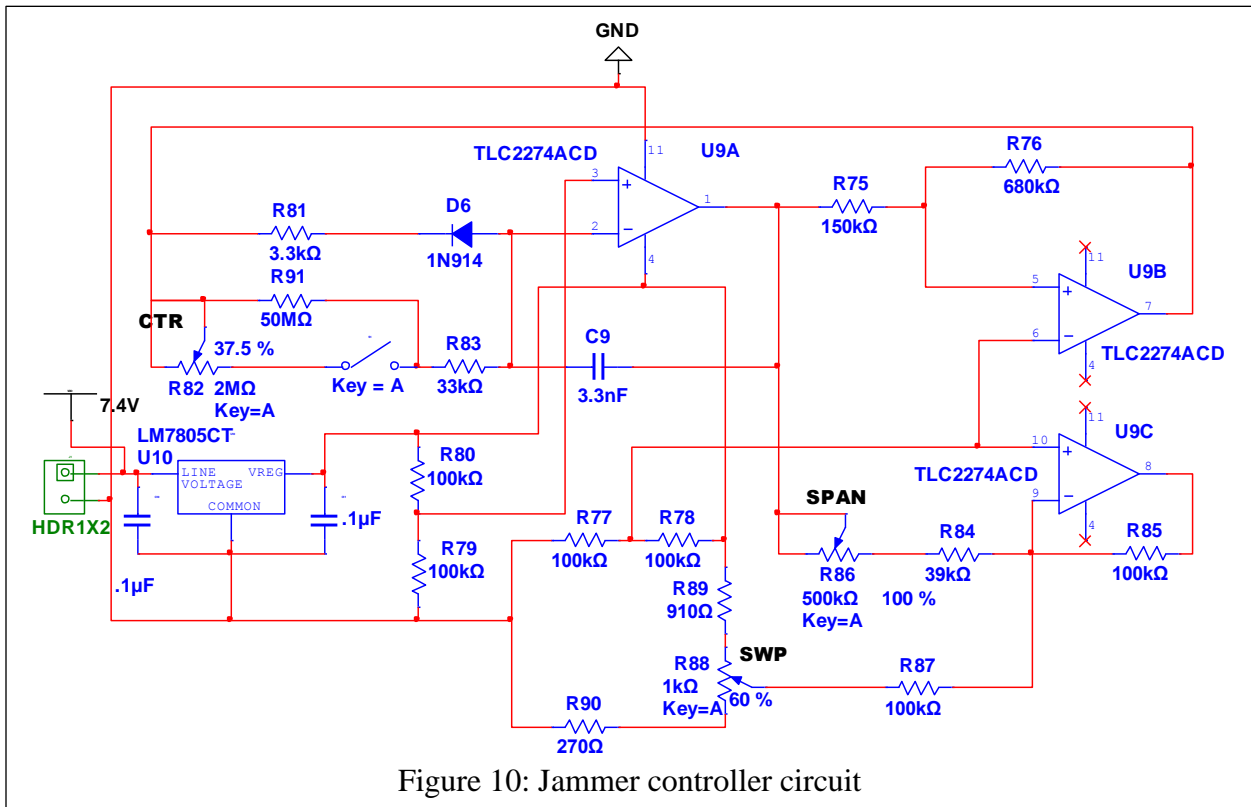

Figure 10: Jammer controller circuit

A second potentiometer, R86 (500 kΩ), provides a variable-gain input to the inverting summer. This permits an adjustable peak-to-peak voltage for the sawtooth, which changes the frequency bandwidth of the VCO output. As measured in lab, the sawtooth voltage span ranges from 320 mV_{pp} to 4.68 V_{pp}, which should provide frequency band coverage as narrow as 16 MHz or as wide as 230 MHz [8]. This variability easily allows coverage of the 100-MHz band from 300-400 MHz for garage opener remotes, but also allows for focusing energy in a much smaller band for experimentation.

The third potentiometer, R88 (1 kΩ), in conjunction with fixed resistors R89 and R90, provides a variable voltage input to the inverting summer via input resistor R87. Lab tests showed this combination provided for DC offsets of 1.79 – 3.99 V, which translates to a center frequency range from about 310 – 435 MHz [8]. Since the target center frequency is 350 MHz, the circuit should perform quite well. The circuit performance testing is summarized in Table 1.

Table 1: Measured controller performance

Performance Parameter	Controller Output	Expected VCO Output
Sweep rate min w/50-MΩ resistor	9 Hz	9-Hz sweep
Sweep rate min w/2-MΩ pot	225 Hz	225-Hz sweep
Sweep rate max w/2-MΩ pot	9 kHz	9-kHz sweep
Jamming bandwidth, min	320 V _{pp}	16 MHz
Jamming bandwidth, max	4.68 V _{pp}	230 MHz
Center frequency, min	1.79 V _{dc}	310 MHz
Center frequency, max	3.99 V _{dc}	435 MHz

The student author, Frank Rossi, Jr., constructed the initial circuit on a prototyping board, shown in Figure 11. Figure 12 shows him doing bench tests with an oscilloscope and DC power supply.

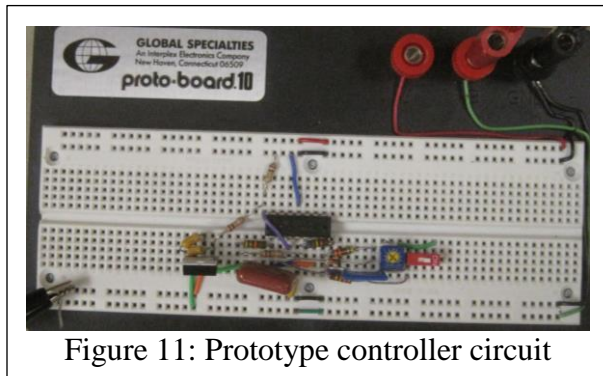

Figure 11: Prototype controller circuit

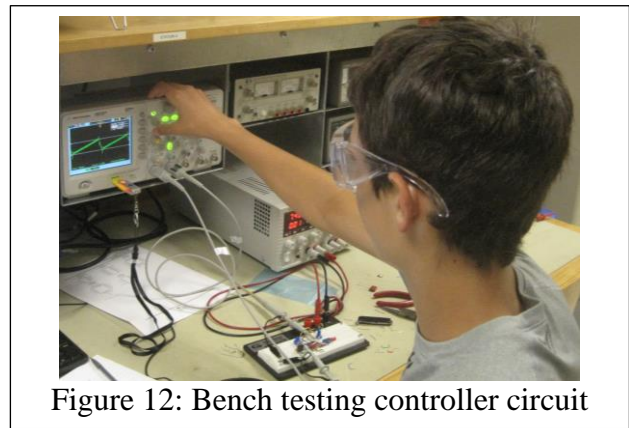

Figure 12: Bench testing controller circuit

He also did the initial PCB layout using Ultiboard [11], shown in Figure 13, and soldered the first board.

Our technician, Michael Holtz, made a few minor tweaks to the layout and soldered the board that was tested for this paper. It is shown in Figure 14. The following section describes the experience of designing and building the Jammer Controller from the perspective of our high school student.

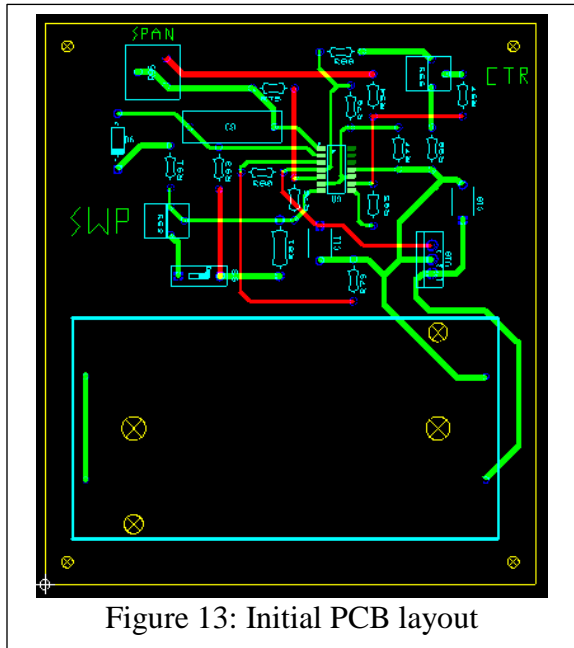

Figure 13: Initial PCB layout

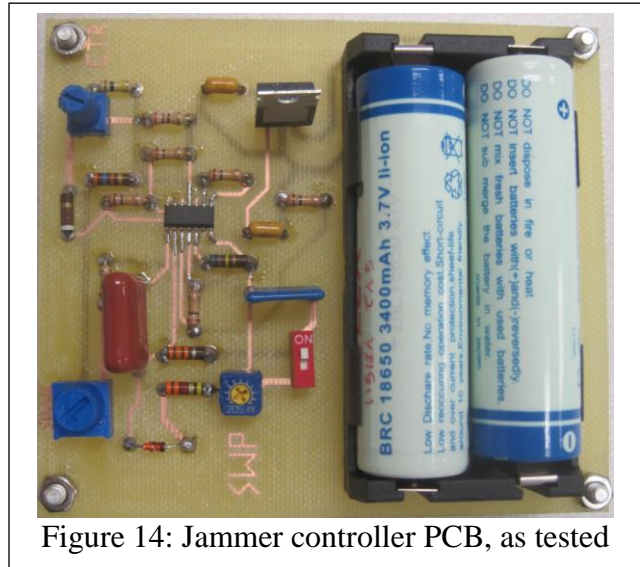

Figure 14: Jammer controller PCB, as tested

Student Experience:

As one of the students working on this jammer project, I had a few expectations coming into it. First, I expected to learn some basics of electrical engineering. I had never had taken anything resembling a formal course on the topic, and what I did know came from science kits and kids' books I had been exposed to as a child. On the one hand circuits seemed simple. Connect a light

bulb to a battery with wires and the bulb lights up. I knew that more complicated circuits existed, such as the ones in radios, but they were completely foreign to me. In this project I wanted to learn how these more complicated circuits worked.

I learned a lot from this project. First, I learned that research takes time. Although we worked diligently during the times we met, other time commitments sometimes made it difficult to schedule meetings. Weeks could go by without progress, and unfortunately we were unable to finish in the time we had planned. I also learned the importance of checking and saving our work after each and every step. Because of this, when a problem cropped up we were quickly able to isolate it and then solve it, something that could have been a lot more difficult without this. I also learned a great deal about electrical engineering. I learned Ohm's law. I learned what resistors, potentiometers, and capacitors were. I learned how to create and print circuits with a computer, how to test them with oscilloscope and spectrum analyzer, and how to solder the parts together. These were all new to me before, but I learned them over the course of the project.

I greatly enjoyed this whole project, but my favorite part was the hands on aspect, when I got to build real circuits with physical pieces, instead of on the computer. I especially liked soldering the final board together, even though it was sometimes a bit frustrating. I only had a few disappointments. Sometimes, on some of the more complicated pieces of the circuit, I didn't really understand how they worked. I followed instructions and got the desired result, but I didn't quite understand why. Were I to do this project again, I would try to change this. I would ask more questions to learn what exactly was going on and why a certain part of the circuit did what it did, instead of just letting it be. I would also try to establish a regular meeting time twice a week. Even if we were not able to meet every single one of those times, it would provide more structure that I think would have forced me to make time for the project and let us finish sooner.

Follow-on Parts of Jammer Project:

The RF amplifier and antenna stages, depicted in Figure 2, have yet to be designed. The current plan is to use a variable-gain amplifier to enable control of transmission power. The higher frequencies of RF sections entail challenges not encountered in circuits like the controller. PCB layout and impedance matching are critical to maximize power transmission. Because its output is RF, the VCO will be part of the RF amplifier. Components will use surface mount technology (SMT) instead of the through-hole technology (THT) used for the controller. Even prototype circuits, to be effective, must be implemented with printed circuit boards.

Multiple antennas are to be constructed and compared. Baseline performance will be established with a simple quarter-wave monopole. Alternative designs planned for testing include normal mode helix, biconical, discone, and patch antennas [2,12]. A patch antenna would be ideal, if it could match or best other designs, because it could be incorporated onto the same PCB with the amplifier components.

Lessons Learned

The biggest lesson learned by Professor Harding was to not try to do too much too fast. Working with all four of the students at the same time proved to be unwise. Although all very sharp, they were also all high school students with no electronics background, which meant each needed a lot of guidance and supervision. As such, Professor Harding and Mr. Holtz found it difficult, often impossible, to give sufficient help to all four students.

The mock IED was the easiest part of the project. It went quickly, finished in a few weeks. The controller was much more complex, and took substantially longer to design and build. Nevertheless, it was still relatively straightforward, the student involved was very engaged, and the design and proto-board circuit were achieved just a few weeks after the mock IED was finished.

The RF amp and antenna design, however, require more sophistication, and Professor Harding has less experience in those areas. Moreover, the antenna testing required a piece of equipment called a vector network analyzer [13], which he had never used before. In “time-sharing” among the four students, he was often not able to provide sufficient help to the students working the RF amp and antenna designs, and both became discouraged.

In retrospect, it would have been wise to work with only one or two students at a time after the initial two meetings. Given some of the other commitments of the professor and technician, it was unrealistic to plan for project completion in one summer. A better plan would have been to focus on the mock RCIED and controller the first summer, then the RF amp and maybe antenna the next summer.

Conclusion

Overall, indications are that the Jammer Project was a good idea, although implementation would have been better if done in stages. Sharp high school students clearly can be mentored through a fairly advanced project, but need very substantial oversight. As such one should take care to ensure individuals performing the supervision have sufficient time to invest. In this particular project, it would have been wise to move more slowly, working with one or two students at a time so none of them became overwhelmed and discouraged.

Although the entire project is not complete, in the fall of 2016 Professor Harding took the mock RCIED with him on a local high school visit to talk about engineering and technology careers. It was a fun “show and tell” and the students enjoyed it, but it was not complete without a jammer. As it turned out, however, one team of students in the fall 2016 iteration of his EW course produced a jammer that was quite effective. In January he took both the RCIED and the student-built jammer to a presentation for grade school students. It was a huge hit with the kids. Explained in the right terms, even grade school students can understand what the jammer does, and they really enjoyed “pushing the buttons”. Our plan is to finish the project and use it for recruiting purposes as originally planned, although it is not clear at this point whether we will engage another high school student or finish the project ourselves.

-
- [1] Harding, G. L. (2014). An Undergraduate Course in Military RF Electronic Applications, aka Electronic Warfare. *2014 ASEE Annual Conference Proceedings*, American Society for Engineering Education (p. 14).
- [2] Adamy, D. (2001). *EW101: A First Course in Electronic Warfare*. Norwood, MA, USA: Artech House, Inc.
- [3] (2011). *Rocker Switch Datasheet*. Southampton, PA: CW Industries
- [4] (2015). *PTQ-11050-C Enclosure*. Bud Industries.
- [5] Agilent Technologies. (2009, July) *Agilent 9340B Handheld Spectrum Analyzer User's Guide*. Chengdu, China: Agilent Technologies.
- [6] (2008). *AI-3039-TWT-12V-R Indicator Datasheet*. PUI Audio.
- [7] *Garage door opener*. (2017, February 5). Retrieved from Wikipedia:
https://en.wikipedia.org/wiki/Garage_door_opener#Remote_control.
- [8] Crystek Microwave. (2013, February 11). *Voltage Controlled Oscillator-VCO CVCO55CW-0250-0450*. Fort Myers, FL, USA.
- [9] Herrick, R. J. (2003). *DC/AC Circuits and Electronics: Principles & Applications*. Clifton Park, NY: Delmar Learning.
- [10] National Instruments. (2017, February 5). *NI Multisim*. Retrieved from <http://www.ni.com/multisim/>.
- [11] National Instruments. (2017, February 5). *Ultiboard*. Retrieved from <http://www.ni.com/ultiboard/>.
- [12] Volakis, J. L. (2007). *Antenna Engineering Handbook, Fourth Edition*. New York: McGraw-Hill.
- [13] Keysight Technologies. (2015, June 1). *Keysight Fieldfox Analyzers User's Guide*. Keysight Technologies.