

AN INTRODUCTORY POWER ELECTRONICS COURSE LABORATORY

**Donald S. Zinger
Northern Illinois University**

Abstract

Introductory power electronic courses often do not have a laboratory component included with them. Student learning, however, tends to be enhanced by including a laboratory. A set of laboratory experiments that are closely tied to the introductory course is developed. Necessary modifications to the lecture components are discussed. Surveys have shown that the students have found the laboratory useful in their understanding of the course material.

Introduction

Conversion of power using electronics switching circuits has become widely accepted. Using power switches electrical energy can be converted efficiently using compact packages. Because of the increased acceptance of power electronic circuits, courses in power electronics have been added to the curriculum of many schools ¹.

Typically introductory power electronics courses are offered without a laboratory experience. Power electronic laboratories are often offered as an independent course. Such a course structure is implied with the power electronics curriculum suggested as a result of an NSF workshop on power electronics ¹. The majority of engineering students, however, are active, visual, and sensing learners ^{2,3}. A laboratory experience that would allow students to visualize the concepts of the course as well as see practical applications of the theory would be beneficial to such students. Laboratories included in the main course, as opposed to an auxiliary laboratory course, have the advantage of reinforcing the main concepts as they are presented.

This paper discusses a series of laboratory exercises that are included in an introductory power electronics course. The laboratory developed consists of various steps in the design of a power electronic converter. Each of the steps includes some of the basic concepts described in lecture. To facilitate the laboratory it is necessary to coordinate the lectures with the experiment which may require changing the order in which the material is presented.

Laboratory Experiments

The laboratories included in the course were developed to allow the student to work through various stages of designing a dc to dc buck converter. A general schematic of the overall circuit is shown in fig. 1. The current laboratories consist of an introduction to switching converter concepts, a gate drive circuit design, choice of values for the major components in the converter, inductor design, control circuit design, and completing the final circuit. These experiments were

chosen to allow the student to build up to a complete circuit and still stay coordinated with the lecture portion of the course. This will allow the students to have a completely operational circuit at the end of the course without being overwhelmed in the middle of the course.

The first experiment consists of investigating a simple switched circuit. It is designed to help students understand the basic principles of these circuits such as duty cycle and average circuit values. It also allows the student to become oriented with the laboratory equipment. In this experiment students set up a predesigned low power switching circuit. It is designed to run at a relatively low frequency so that switching time would not be important. A large inductor is used so that the current is essentially constant and the circuit behavior becomes nearly ideal. This allows the student to see results that appear very much like the ideal conditions discussed in text books.

The next experiment consists of investigating the drive circuits used to switch the main power transistor. The major topology for the circuit is given to the student but the student is required to calculate values for the major components. The current laboratory uses optically coupled circuits to isolate the power transistor from the control system. Circuits with and without a totem pole stage are investigated to observe the improvement in switching speed obtained by that stage.

The third assignment is actually not a laboratory experiment but a circuit design and simulation. In this assignment the students are to find values for the major power components as well as gains required in the control circuit. Components to be specified are the power filter inductor and capacitor. These are designed based on current and voltage ripple requirements. Also, a gain for a simple proportional controller is chosen for a given output voltage error requirement based on a linearized model of the circuit. The linearized model is given to the students with a reference as to how it is derived.

When the proper component values and gains were found, students are required to simulate the circuit to verify their results. This allows the students to follow an accepted procedure of verifying a design before actually constructing the circuit and will make the students more confident in their abilities. It will also reduce subsequent laboratory times since it should not be necessary to change the design in the laboratory. Currently PSPICE is used to do the

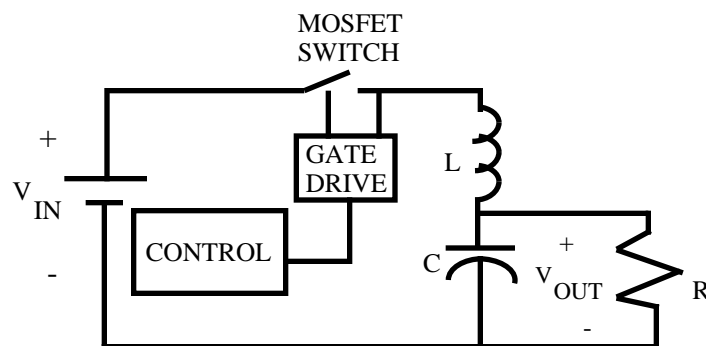

Fig. 1. General block diagram of circuit used in laboratories.

simulations, but other similar circuit simulator packages would be acceptable.

The fourth assignment in the laboratory is to construct an inductor of the value found in the previous assignment. Students are given a standard magnetic core along with data sheets on that core. The students are required to calculate the required number of turns needed to achieve the proper inductance. In their calculations they must account for the saturation effect caused by the large dc offset. The students are then required to verify their design by taking measurements in the laboratory and calculating the inductance. This gives the students the opportunity to see some the special requirements required for power components as well as addition experience in laboratory measurement procedures.

In the fifth laboratory, students work with a commercially available pulse width modulator (PWM) integrated circuit that will be used as the main control unit. The students are given the data sheets of the integrated circuit and investigate the various features of that circuit. For example, the students are required to find components necessary for a given start-up delay and a given current limit. Also the proportion gain determined in the third assignment is implemented using the PWM integrated circuit. The students are, therefore, required to determine the additional components needed to implement this gain.

The sixth and last part of the circuit consists of the final assembly of all the various parts of the circuit previously designed. The gate drive circuit is interfaced with the controller circuit and used to switch the main power MOSFET. The filter components designed previous are placed in the output circuit. The circuit is checked to verify that it operates according to the design specification.

Through the various semesters this course has been offered there have been a number of changes and improvements. For example one semester the students were to try to use a pulse transformer instead of the an opto coupler to isolate the drive circuit from the control. The pulse transformer was tried to guarantee that the output would be off unless actively turned on. Problems such as saturation and just making sure the windings had the correct polarity made the practical implementation of this circuit difficult. Therefore the opto coupler was reinstated.

Another change in the laboratories in the past few years was in the gate drive experiment. This was originally an experiment to investigate the switching characteristics of a MOSFET. It was found, however, that students had difficulty understanding the gate drive circuit when they built the final circuit. Therefore, the second experiment was changed to emphasize an understanding of the gate drives rather than the MOSFET.

Lecture Structure

In order for the students not to go into the laboratory blind, it is good to introduce the main concepts they will encounter in the lab before the students attempt it. The layout of most introductory texts on power electronics does not well suite the structure of the laboratory. Typical texts follow the basic outline suggested by the 1996 NSF Workshop on Developing Power Electronics Curriculum ¹. Typically dc-to-dc converter of the type constructed in the laboratory are placed in the middle of the text behind introductory material and rectifiers. Also

switches are often considered to be ideal and therefore the specific requirements needed to switch the devices are often placed in supplemental material toward the end of the text. This, however, does not fit the need to have a good working gate drive early in the course so as to properly switch the main power device effectively.

A high level outline of the lectures used in this course is shown in Table I. For this course the switching devices and their driving circuits are placed fairly early in the course material. Thus the lecture material will be covering the gate drives as students are investigating them in the laboratory. DC-to-DC converters are also covered earlier than in a typical power electronics course. This gives students knowledge of the basic circuit topology required in their design before they encounter it in the laboratory. After the materials required in the laboratory have been discussed in the lecture, other major topics in power electronics are covered.

Besides rearranging major topics in the lecture, other adjustments are required. Often problems that occur in the laboratory are of brought up as discussion topics in the lecture. This is important to help keep the lectures tied to the laboratory. Also minor topics that do not fit in the major categories might need to be explained in the lecture. For example the major lecture plan does not have a place for magnetic design. Therefore, to prepare the students for the inductor design laboratory, a special lecture on inductor design needs to be placed in with the dc-to-dc converters.

Laboratory Equipment

The inclusion of the laboratory did not add major expenses to the delivery of the course. Standard equipment such as oscilloscopes, signal generators, and power supplies that are found in most electrical engineering laboratories can be used for most of the experiments.

The main power supply for the converter might require some higher power capabilities than a standard laboratory bench supply. The goal in the laboratory was to have a power converter with as large of output power capacity that could be obtained in the laboratory. Thus the initial design required a supply capable of 15 V and 2.5 A. Since the laboratory had only one such supply, students were required to share the supply. To reduce the inconvenience caused by sharing the supply the power requirements were reduced to allow the standard 15 V 1 A supplies to be used.

Additional useful equipment would be isolated voltage probes and current probes. Although

Table I. Lecture outline used in course.

- I. Introduction and Basic Concepts
- II. Switching Devices and Gate Drives
- III. DC-to-DC Converters
- IV. Rectifiers
- V. Inverters

ungrounded voltages could be observed by using two probes and a differential setting on an oscilloscope, using isolated voltage probes would reduce the common mode noise and would allow more signals to be observed. Similarly currents could be measured by taking voltages across resistors, but it would be less intrusive to use a current probe.

Costs of isolated voltage probes are relatively inexpensive. Current probes with the frequency bandwidth required for the laboratory are somewhat more expensive. Relatively cheap current sensors can be substituted, however, with the loss of some convenience.

Additional costs would come from the circuit components used. These would include the power MOSFET, the controller circuit, the inductor core and a few miscellaneous components. The total cost of these components is less than \$20 per group and should not be a major burden on the laboratory budget.

Student Feedback

Students have responded well to the laboratory experience. As illustrated in fig. 2, a student survey has shown that the students believed that the laboratory projects helped in their understanding of the course material. None of the students said they did not learn anything from the laboratory while 90% of the students found a better than average contribution to the learning.

In another question in the same survey the students also displayed approval for the laboratory. Since this course was only a three credit hour course, a lecture period was removed in order to account for the laboratory time. They were, therefore, asked in the survey if they would prefer additional lecture time over the laboratory. The responses given in fig. 3 show that the students did not think that the additional lecture time would be an improvement over the laboratory.

Conclusion

From this experience it is seen that it is possible to operate a laboratory in conjunction with an introductory power electronics course. Some modifications are required with the standard lecture material in order for it to have a good fit between the laboratories and the lectures. Typically the cost of equipment is not a drawback in developing the laboratory since much of the equipment is standard in other labs. Students generally appreciate the laboratory and find it a useful learning experience.

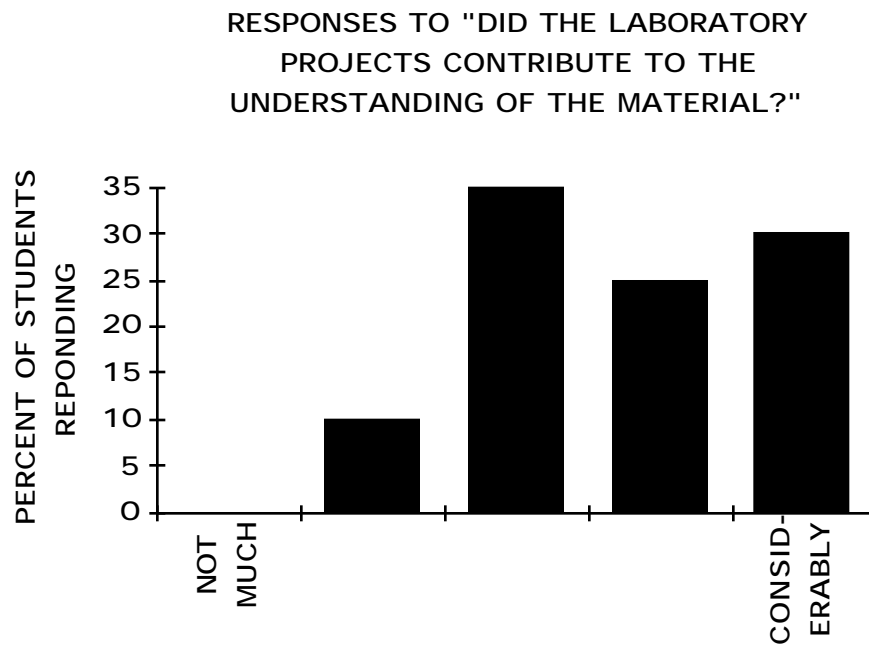

Fig. 2. Responses to survey question on laboratory contribution to material learned.

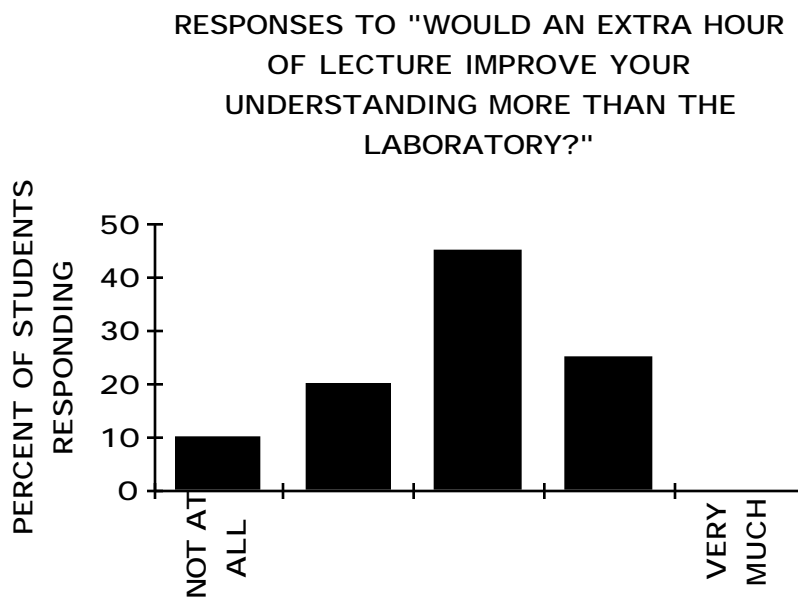

Fig. 3. Responses to survey question on whether it would have been better not to sacrifice an hour per week of lecture time for the laboratory.

References

1. Issa Batarseh. "NSF Workshop on Developing Power Electronics Curriculum: Final Report," April 1996.
2. R. M. Felder, " Learning and Teaching Styles in Engineering Education," *Engineering Education* Vol. 78 No. 7 April 1988, pp. 674-681
3. S. M. Kresta, "Hands-on Demonstrations: An Alternative to Full Scale Lab Experiments," *Journal of Engineering Education*, Vol. 87, No. 1, January 1998, pp. 7-9.

DONALD S. ZINGER

Donald S. Zinger is an assistant professor at Northern Illinois University where he has been since 1993. There he teaches courses and does research in the areas of power electronics, electric machines, and control. Dr. Zinger received his Ph. D and masters degrees from the University of Wisconsin, Madison in 1988 and 1983 respectively. He received his BS degree in 1977 from Illinois Institute of Technology.