

## **An Upper-level Undergraduate Course in Renewable Energy with Power Electronics and Simulink**

**Dr. Harry O Aintablian, University of Washington**

Harry Aintablian is an Associate Teaching Professor of Electrical Engineering at The University of Washington at Bothell. He received his Ph.D. in Electrical and Computer Engineering from Ohio University. His research interests include power electronics and renewable energy systems. He worked for several years in aerospace power electronics/power systems at Jet Propulsion Laboratory and at Boeing Space Systems.

# An Upper-level Undergraduate Course in Renewable Energy with Power Electronics and Simulink

## Abstract

To meet the demand for skilled professionals in renewable energy in the Puget Sound region, an upper-level undergraduate course was developed. The course is primarily focused on renewable energy sources with added emphasis on the electrical aspects and the power electronics associated with such technologies. Simulink and SimPowerSystems based simulation exercises are integrated in the course to enhance student motivation and to provide students with marketable skills. The paper describes the contents of the course, associated power electronics topics, sample Simulink exercises and the teaching methods used. The effectiveness of the course is assessed through student feedback. The elective course in renewable energy was offered in winter 2021 and spring 2022 at The University of Washington at Bothell.

## Introduction

According to the US Energy Information Administration (EIA) annual energy outlook [1], the share of renewables in US electric energy generation more than doubles from 2021 to 2050 (Figure 1). Moreover, solar energy generation accounts for almost three-quarters of the increase for renewable energy (Figure 1). The growth in wind energy generation is curtailed after the phase out of the production tax credit for wind energy is 2024 [1]. Furthermore, battery storage compliments solar energy generation and helps reduce nonrenewable generation to meet peak electric power demand [1].

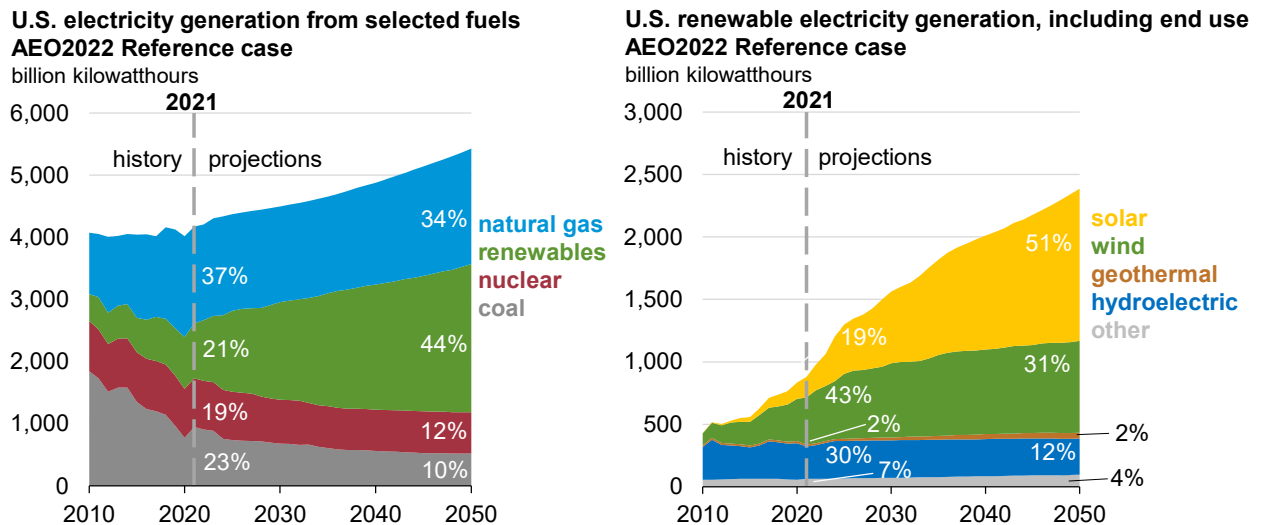

Figure 1: US Energy Generation Projections

According to the US Department of Energy (DOE) 2022 Energy and Employment Report [2], the US had approximately 858,000 renewable energy jobs in 2021. This included approximately 334,000 in solar energy, 120,000 in wind energy and 65,000 in hydroelectric energy generation.

Cost reductions and environmental considerations are the driving factors in the growth of renewable energy. The increase in demand for renewable energy generation over the next few decades, will require additional workforce. According to the DOE 2022 Energy and Employment Report [2], investments and installations of renewable energy could create over 1 million jobs in the US by 2035.

The rapid growth in renewable energy generation requires skilled professionals. This course was developed to offer students foundational skills in renewable energy systems. The course is primarily focused on renewable energy sources with added emphasis on the electrical aspects and the power electronics associated with such technologies. This course does not address power system-level topics such as grid integration and economics of renewable energy sources. The course instruction is enhanced by Simulink model simulations to provide students with a graphical environment for simulating and analyzing renewable energy systems. This course can serve as guide to other instructors interested in initiating a course in renewable energy.

In this paper the contents and teaching methods of a course in renewable energy technologies are presented. Example Simulink assignments are described. Reflections on the student experience are presented and lessons learned are highlighted.

## **Course Content**

Table 1 outlines the topics covered in the course. During week 1 of the course (two lectures) an overview of traditional and renewable power generation is presented. The latest statistical data and future projections for renewable energy generation and consumption are presented from the US EIA [1]. During the second lecture period three-phase circuits and the topic of power factor are reviewed. Even though students have been exposed to three-phase circuits during their second circuits course, a review would help them to succeed in a more advanced course.

The second segment of the course introduces students to the basics of photovoltaic cells and the electrical properties of solar modules and arrays. Students gain familiarization with current versus voltage characteristics of solar cells, modules and arrays. Using the electrical model of a solar module students can assess power losses, shading effects and mitigations for shaded and degraded modules. In conjunction with the topic of Maximum Power Point Tracker (MPPT) students are presented with the power electronics associated with solar power including dc-dc converters and dc-ac inverters. Students appreciate the importance of power electronics for optimizing the power received from a solar array by studying the three commonly used MPPT algorithms. Finally, students learn how to design solar arrays for grid-connected systems as well as off-grid systems with battery storage. Students are introduced to the chemistry and elements of lead acid batteries. Subsequent coverage is focused on the properties, sizing and charge control electronics of lithium-based batteries.

Table 1: Course Topics

<b>Week</b>	<b>Topic</b>
<b>I. Introduction and review</b>	
1	Introduction to renewable energy technologies Review of electric power
<b>II. Photovoltaic Energy System</b>	
2	Electrical properties of solar cells
3	Electrical properties of photovoltaic systems
4	Control of photovoltaic systems: Maximum Power Point Tracking; dc-dc converter control.
5	Off-grid solar arrays with energy storage
<b>III. Wind Energy System</b>	
6	Wind turbine technologies
7	Wind turbine characteristics
8	Wind generator technologies and control
<b>IV. Other Renewable Energy Sources</b>	
9	Other renewable sources: concentrating solar arrays, ocean energy, hydroelectric power generation
10	Other renewable sources: concentrating solar arrays, ocean energy, hydroelectric power generation

The third segment of the course provides students with a detailed analysis of wind power systems. First, students are introduced to aerodynamic principles of wind turbines, wind turbine rotors and the maximum power that can be extracted from the wind. Emphasis is placed on the most common horizontal-axis upwind turbine technology. The last portion of this segment is focused on the electrical generators in the context of wind power systems. Since students do not have sufficient background in electrical machines, synchronous and induction machines are introduced with their physical descriptions, principles of operation and terminal attributes such as torque-speed characteristics. In regards to the power electronics associated with wind turbines, fixed-speed and variable speed wind system configurations are described. Emphasis is placed on the power converters used for variable-speed synchronous generators with dc link conversion and the doubly-fed induction generator with multiphase rotor windings.

In the fourth segment of the course, students are introduced to concentrating solar power (CSP) systems. Concentrating solar systems differ from photovoltaic solar panels in that they use

mirrors to concentrate the radiation of the sun to heat thermal fluid. The resulting thermal energy is used to generate pressurized steam to drive a turbine/electric generator to produce alternating current (AC). The properties of the four major types of CSPs (parabolic trough, solar tower, Fresnel reflector, dish Stirling) are described. In addition, students are introduced to thermal energy storage and are presented with example installations.

Washington state is the largest hydroelectric power producer in the US [1]. Washington's Grand Coulee Dam is the largest hydroelectric power plant in the country with a capacity of 6.8 Gigawatts [3]. Hydroelectric power accounts for about 66% of Washington's electricity generation [1]. Renewable sources other than hydroelectric power, led by wind power, account for about 10% of electricity generation in Washington state. Thus, it is imperative that the course include focus on hydroelectric energy.

Hydroelectric energy harvests the power of water in motion to turn the blades of a turbine to generate electricity. The three classes of hydroelectric power are described, namely run-of-the-river, traditional hydroelectric (dam based) and pumped-storage systems. The forms of energy associated with water (potential, pressure, and kinetic) as well as the three major types of turbines (impulse, reaction, and waterwheel) are discussed. Students are introduced to pumped-storage hydroelectric power where water is pumped from a lower to upper reservoir when electricity demand is low, and water is released through a turbine to generate electricity when electricity demand is high.

Washington and Oregon hold vast ocean energy resources. Thus, it is important for students in the Northwest to learn about the energy that can be harvested from the ocean which could be key to the development of future sustainable energy resources in the region. Ocean energy technologies are not yet widely adopted. Development of this energy is costly and challenging. Some of the challenges include building the infrastructure and the transmission of electric power.

Ocean waves are periodic with varying frequency and amplitude. A variety of wave energy conversion (WEC) technologies can be used to harvest the energy of ocean waves. Students learn about four types of WEC technologies: point absorbers, attenuators, overtopping devices and oscillatory water column terminators. Point absorbers extract energy from the rise and fall of waves with a floating buoy. The flexing of attenuators by waves yields mechanical power from a hydraulic motor which is converted to electric power by a generator. In overtopping devices, ocean water fills a reservoir which is drained through a hydroelectric turbine similar to a hydroelectric dam. Finally, an oscillatory water column terminator acts as a piston forcing air in and out of a chamber. This airflow through a turbine drives a generator to produce electric power.

Tidal energy is harnessed from the rise and fall of tides. There are two categories for tidal power generation technologies: tidal barrages and tidal current turbines. A barrage is a structure that is similar to a dam. It is usually installed across an inlet of an ocean bay. Water is allowed to flow into a bay during high tide which is then released through a turbine-generator during low tide, thus converting potential energy into electric energy. Tidal current turbines are similar to wind

turbines. They are usually placed on the sea floor thus extracting kinetic energy from the strong tidal flow.

### **Course Objectives and Teaching Method**

After successfully completing this course, students will be proficient in a variety of renewable energy technologies including solar, wind, hydroelectric, and ocean energy. They are expected to be competent in renewable energy system modeling, analysis and design. Additionally, students are expected to gain a good understanding of the power electronics used in renewable energy systems.

Student learning is assessed by different methods including homework assignments, quizzes, discussions, simulation projects and exams. The Canvas learning management tool is used to post course content, submit assignments and collaborate with others. Lecture material is presented in PowerPoint slides that are used to summarize key facts and to convey complex ideas. These slides include images and charts to arouse student interest and to reinforce a given topic. Lecture slides are posted on the course Canvas site beforehand to facilitate preparation.

Class participation/discussions are highly encouraged. Occasionally, after a topic is described, students are formed into groups and are presented with questions to guide them through discussions about the theories, pros and cons and practical considerations for a particular renewable energy technology. In-class example problems are solved by writing step-by-step solutions on a tablet. The final solution for a given problem is reflected on. Additionally, students are provided with opportunities for practice by having them work in pairs to work on the solution of a given problem. The use of critical thinking skills and the evaluation of the results are emphasized.

### **Simulation Assignments**

It is often not feasible to use laboratory equipment for an energy conversion course due to cost and space requirements. Instead, model-based engineering is used to simulate a system before implementation of hardware. The energy conversion industry has been using an integrated simulation approach for modeling and simulation to verify designs and thus reduce development time and cost. In this course, the Simulink tool is used to enhance student learning. The simulation assignments motivate the students and help with understanding complex topics.

Simulink with SimPowerSystems is used to model energy sources, transmission lines, transformers and electrical machines, and power electronics converters. Renewable energy source models and relevant system model components are readily available. Students use Simulink graphical models to analyze the performance of a given renewable energy system such as solar or wind systems. The following table lists the simulation assignments adopted in the course followed by brief descriptions of two sample simulation assignments.

Table 2: Simulink Assignments

	<b>Simulation Project</b>
1	Solar module IV and PV characteristics
2	Partial shading of solar array
3	Solar array with MPPT
4	Isolated wind turbine induction generator
5	Wind farm using a type IV turbine
6	Wind farm using DFIG

### **Examples of Simulation Assignments:**

#### Example 1: Partial shading of solar array

Figure 2 represents the Simulink model of a solar array consisting of three modules, with each module having 20 series-connected cells. The modules are configured for:  $P_{max} = 83 \text{ W}$ ,  $V_{oc} = 12.64 \text{ V}$ ,  $I_{sc} = 8.62 \text{ A}$ ,  $V_{mp} = 10.31 \text{ V}$  and  $I_{mp} = 8.07 \text{ A}$ . The user can also choose from a few hundred vendor-provided modules. Bypass diodes mitigate against shaded or malfunctioning modules. The variable dc source is used for measuring the IV and PV characteristics of the solar array. Temperature and irradiance parameters are applied to each module. Module 1 is configured for full-sun ( $1000 \text{ W/m}^2$ ) while partial shading is applied to the two other modules with respective irradiances of  $300 \text{ W/m}^2$  and  $600 \text{ W/m}^2$ .

Students are asked to simulate the system model for different combinations of irradiances for each module. Figure 3 shows the IV and PV curves of the partially shaded array for the irradiances depicted in the model of Figure 3. The PV curve exhibits three maxima. The global maximum power of  $104.5 \text{ W}$  is at a voltage of  $21 \text{ V}$ . This maximum power is less than 50% of the maximum power ( $250 \text{ W}$ ) if all three modules were at full-sun with no shading.

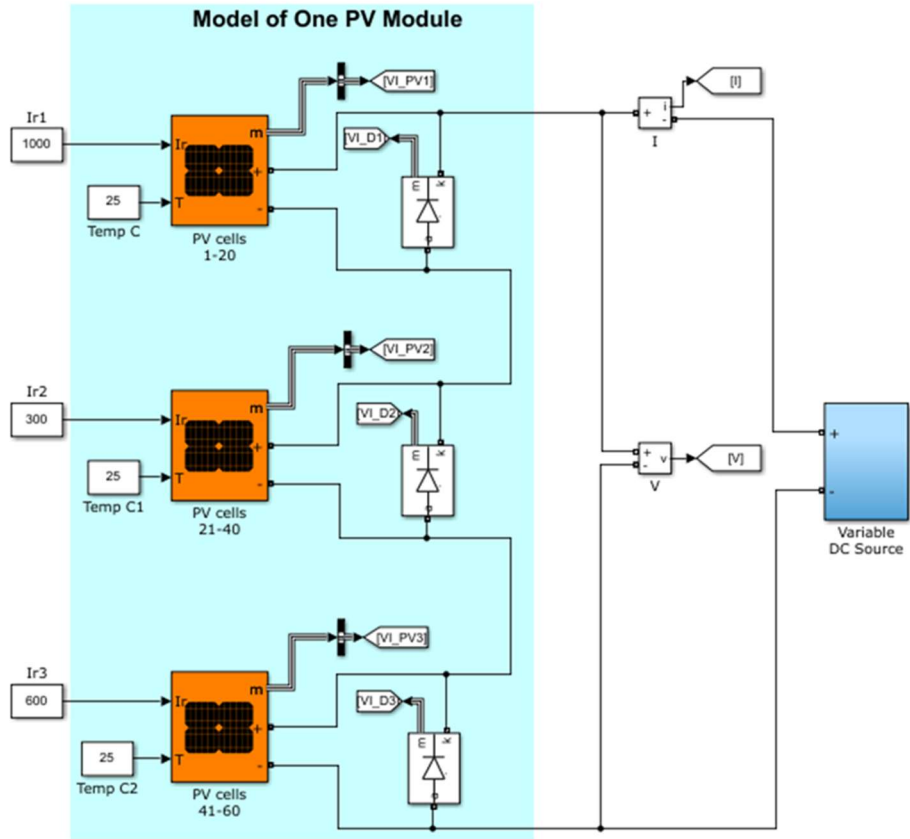

Figure 2: Simulink model for partial shading of solar array

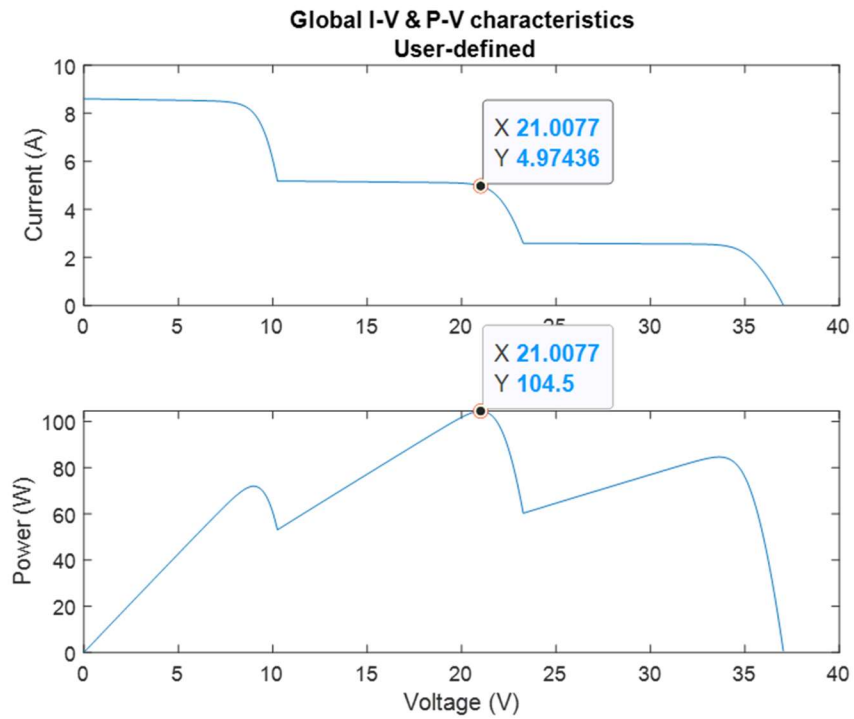

Figure 3: IV and PV characteristics of a partially shaded solar array



## Example 2: Isolated Wind-Turbine Induction Generator

Figure 3 displays the Simulink model of a wind turbine driving a 480 V, 275 kVA induction generator, a power factor correction capacitor bank and a three-phase load. The wind turbine model uses a lookup table to compute the turbine output torque as a function of its speed (Figure 4).

The simulation is run at a wind speed of 10 m/s. This example illustrates the startup and the steady-state operation of the wind turbine/induction generator system. The speed of rotation of the induction machine is above 1 pu indicating operation in generator mode (Figure 5). Figures 6 and 7 show that the output power is 200 kW and the output three-phase voltages are approximately 450 V<sub>peak</sub>. Students can vary the wind speed, the power factor correction capacitor value and the load.

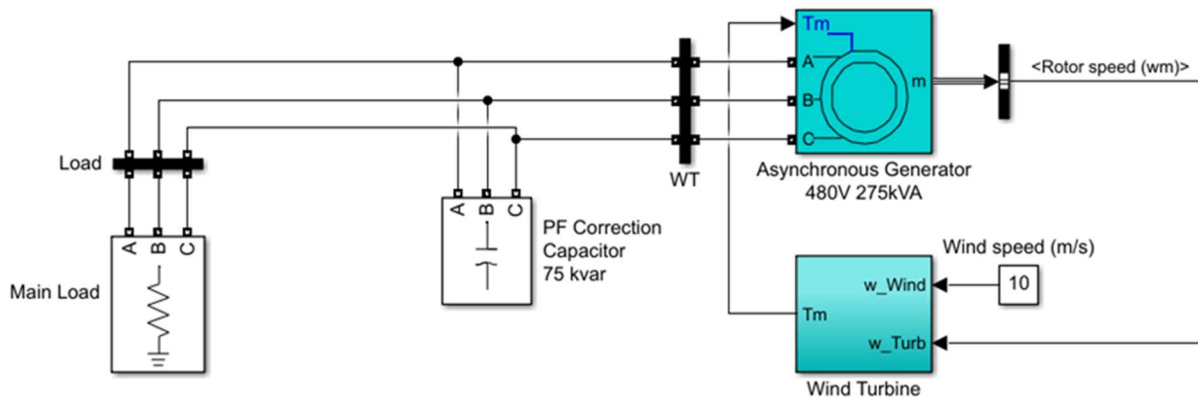

Figure 4: Wind-turbine driven induction generator model

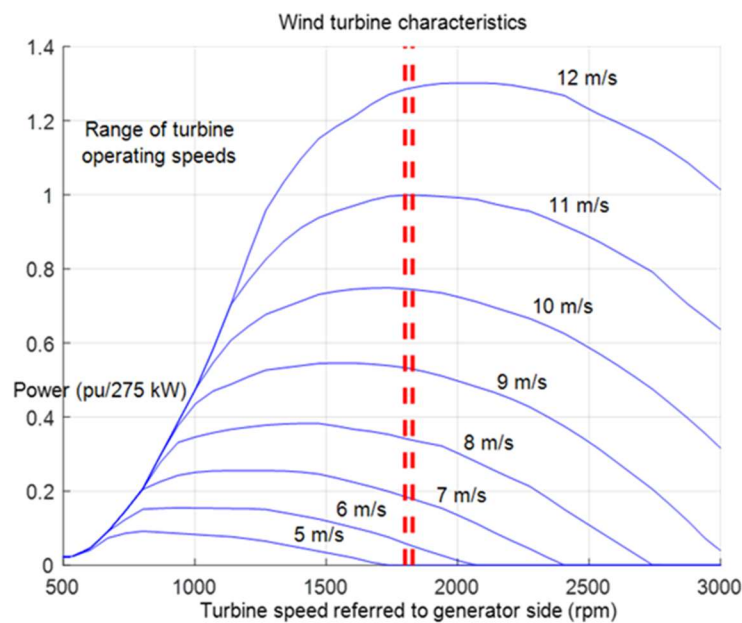

Figure 5: Wind turbine torque-speed characteristics

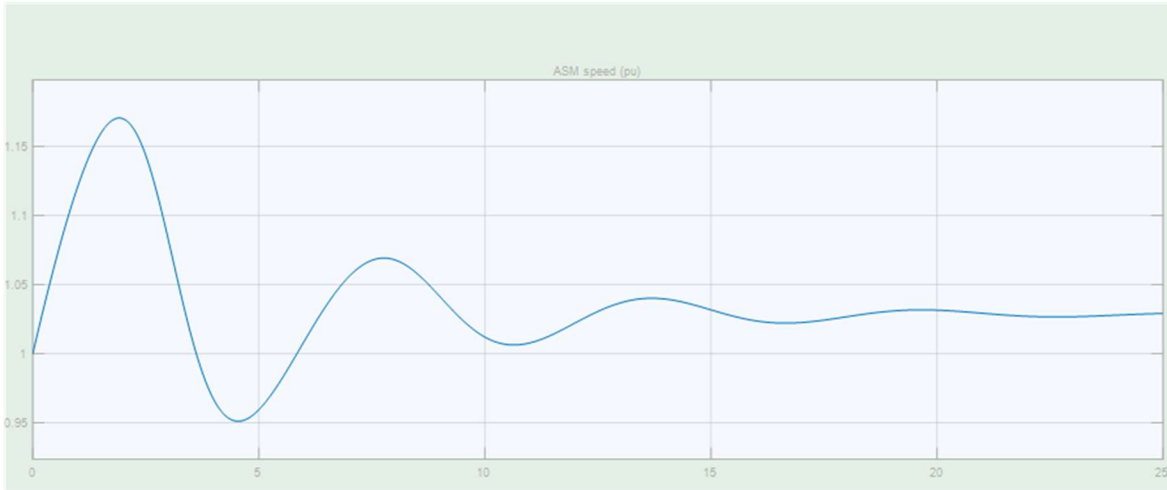

Figure 6: Induction generator speed of rotation (pu)

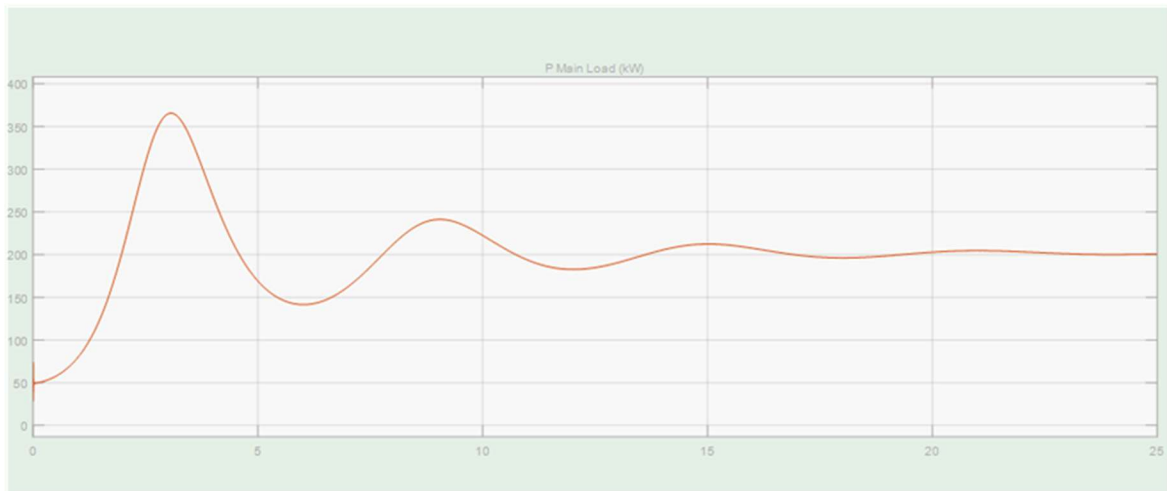

Figure 7: Output power (kW)



Figure 8: Three-phase bus voltages

## Student Evaluations and Feedback

The course was offered twice with high enrollments (Table 3). The majority of students enrolled in the course were graduating seniors. The student evaluation scores were at the high end of the scale. Overall Summative Rating (OSR) provides an overall index of the course quality. Challenge and Engagement Index (CEI) relates to how academically challenging students found the course and how engaged they were.

Table 3: Student enrollment and evaluation results

Quarter	Enrollment	Overall Summative Rating (OSR)	Challenge and Engagement Index (CEI)
Winter 2021 (online)	30	4.7 (5=highest)	4.8 (7=highest)
Spring 2022 (in person)	21	4.2 (5=highest)	4.9 (7=highest)

Student feedback has been positive. The following is a collection of student comments:

- Students found the class intellectually stimulating
- Students thought the class examples and simulation assignments were realistic and informative
- Students found the lecture slides well organized and they thought the lectures and class notes greatly contributed to their learning
- Students gained a theoretical understanding of the material presented as well as familiarity with real-world applications
- Students appreciated the mix of renewable energy topics and the associated power electronics
- Students recommended spending more time in class to explain the Simulink models and simulations

## Conclusions

Students showed great enthusiasm for the renewable energy subject material presented during the course. There were frequent questions and discussions during the lectures. The course presented students opportunities to explore career options in the emerging renewable energy field. Additionally, the course offered students a broad understanding of the important role electrical machines and power electronics play in the optimum generation and delivery of

renewable energy. Integrating electrical machines and power electronics helped enhance students' skill sets.

The course instruction was complimented by Simulations (Simulink) that enhanced students' experiences by emulating real systems through a visual medium. Simulink exercises increased student motivation and enhanced student learning by providing them with tools that they would encounter in industry. One of the improvements planned for the course is to increase emphasis on learning how to use Simulink early in the course. It is recommended to introduce a second course focused on the power system aspects and the economics of renewable energy systems.

## References

1. US Energy Information Administration Annual Energy Outlook, 2022.
2. US Department of Energy: US Energy and Employment Report, 2022.
3. Wikipedia online: Grand Coulee Dam: [https://en.wikipedia.org/wiki/Grand\\_Coulee\\_Dam](https://en.wikipedia.org/wiki/Grand_Coulee_Dam)
4. S. Santoso, W. M. Grady, "Developing an Upper-Level Undergraduate Course on Renewable Energy and Power Systems," Proceedings, IEEE PES General Meeting, San Francisco, CA, June 12-16, 2005.
5. Radian G. Belu, "An Undergraduate Course on Renewable Energy Systems with Enhanced Marine Energy Content," ASEE Annual Conference, Virtual Meeting, July 26-29, 2021.
6. David McDonald, "Simulation Learning Experiences in Energy Conversion with Simulink and SimPower Systems," ASEE Annual Conference, Chicago, IL, 2006.
7. Meah, Kala, Barnett, Phillip, Deysher, Paul & Vaisakh, K., "*Project-based Renewable Energy Course for Undergraduate Engineering Students*," ASEE Annual Conference & Exposition, San Antonio, Texas, June 10-13, 2012.
8. G. Masters, *Renewable and Efficient Electric Power Systems*, 2nd ed. Hoboken, NJ, USA: Wiley, 2013