

## Analog to Digital Mechanics Lab Conversion: Lessons Learned

Nancy Denton, Bill Szaroletta, Lloyd Ewing  
Purdue University

### Abstract

To upgrade the laboratory supporting an introductory sophomore-level strength of materials course to reflect current industry practice and address student requests, the authors have begun converting the current experiments from analog instrumentation with hand-recorded data to National Instruments LabVIEW™ based testing. This paper reviews the challenges encountered during the conversion of one experiment; a three-point beam bending experiment investigating the effect of material and cross-sectional area changes on maximum deflection. Approximately eighty students over two semesters beta-tested the LabVIEW™ virtual instrument for load and deflection measurement. The benefits and drawbacks of using the automated data acquisition (DAQ) version of the experiment are discussed from both instructor and student perspectives.

### I. Instructional Approach

This strength of materials course provides the students a hands-on opportunity to experience the theory introduced in the lecture. Laboratory experiments generally follow theoretical development and homework problems on each topic. Laboratory work, including experiment set-up, operation, and data collection, is conducted within a team environment, with each team member having an assigned role. For experiments with a high degree of repetitive activity, such as Three-Point Bending, team members are encouraged to rotate roles after several iterations. Though the experimental work is done in teams, each individual provides a written report that is submitted within two weeks of completion of the experiment.<sup>1</sup>

Typical laboratory sessions have three to six teams, with teams ranging in size from a minimum of three to a maximum of eight students. Teams are formed by instructor assignment after a brief experiment-specific lecture that explains (and sometimes demonstrates) the hardware and software to be utilized during that particular laboratory session. This method of team formation, which varies the team's make-up from week to week, assures that there is a good mixing of the students and team roles. The practical aspect of this method of team formation is that it mirrors industry, where one does not necessarily expect to work with the same individuals from project to project and responsibilities change with each project.

### II. Introduction to Three-Point Bending

Beam flexure and shear flow theories are introduced to the students in the lecture portion of the strength of materials course. Knowledge gained from prerequisite courses, lecture material and

homework problems enable the students to systematically develop the static free-body diagram, *FBD*, the load rate diagram,  $\omega$ , instantaneous load diagram,  $q$ , shear force diagram,  $V$ , bending moment diagram,  $M$ , slope diagram,  $\theta$  and deflection diagram,  $y$ , for various beam configurations. An example of the Three-Point Bending set-up is shown in figure 1 and the corresponding analysis model baseline is shown in figure 2.



Figure 1: Three-Point Bending Set-up

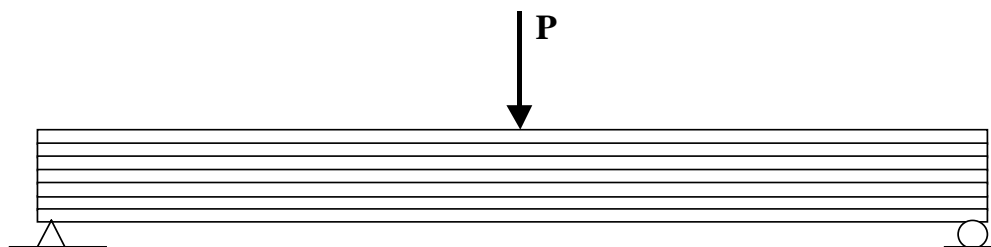

Figure 2: Three-Point Bending Analysis Model

Magill introduced and described the Three-Point Bending experiment in 1995.<sup>2</sup> Consistent with the majority of the laboratory activities in this sophomore level course, the three-point bending laboratory is intended to help students bridge the gap between theory and application while conforming to American Society for Testing of Materials (ASTM) testing standards.<sup>3</sup> In this

experiment, theory involves derivation of the deflection equation from relatively simple analytical techniques and is easily verified by equations found in the appendices of most strength of materials textbooks. Clearly, the case shown in figure 2 corresponds to a simply supported beam with a transverse point load in the center from which the center deflection can be obtained as a function of material and geometric properties.<sup>4,5,6</sup> The effects of material and geometric properties on beam deflection are investigated through tests on 1" wide, 36" long, metal beams. The experiment is first performed to allow comparison of the flexural properties of 1/4" thick aluminum, steel, and brass specimens. The experiment is repeated to allow comparison of the flexural properties of three aluminum specimens that are 1/4", 1/2", and 3/4" thick, respectively. The third iteration of the experiment allows comparison of the flexural properties of 1/4" thick aluminum specimens in stacks of seven beams, one bolted and one unbolted, with the previously tested 1/4" thick aluminum specimen. The entire experiment is completed during one 110-minute laboratory session. Students devote approximately one hour to setup and system calibration, leaving the remainder of the session for data collection and manipulation.

As related by Magill, during the test, each beam is fixtured in a typical Universal Tensile Machine (UTM).<sup>2</sup> The beam's ends are raised while its center remains fixed. Load values are measured through a strain-based 500 lb<sub>f</sub> load cell located above the crosshead ram on the UTM, connected to a typical strain indicator. Deflection is assumed to match the change in position of the UTM's ram, which is displayed on the UTM's digital readout. Linear regression slopes from plots of the load versus deflection data, an example of which is shown in figure 3, are used to derive relationships between deflection and modulus of elasticity and deflection and area moment of inertia. The raw data acquired in figure 3 is from the DAQ system. For these raw data plots, the R<sup>2</sup> correlation is over 0.98 for all three of the regression lines shown, indicating relatively noise-free and linear data from the transducers through the DAQ to the spreadsheet.

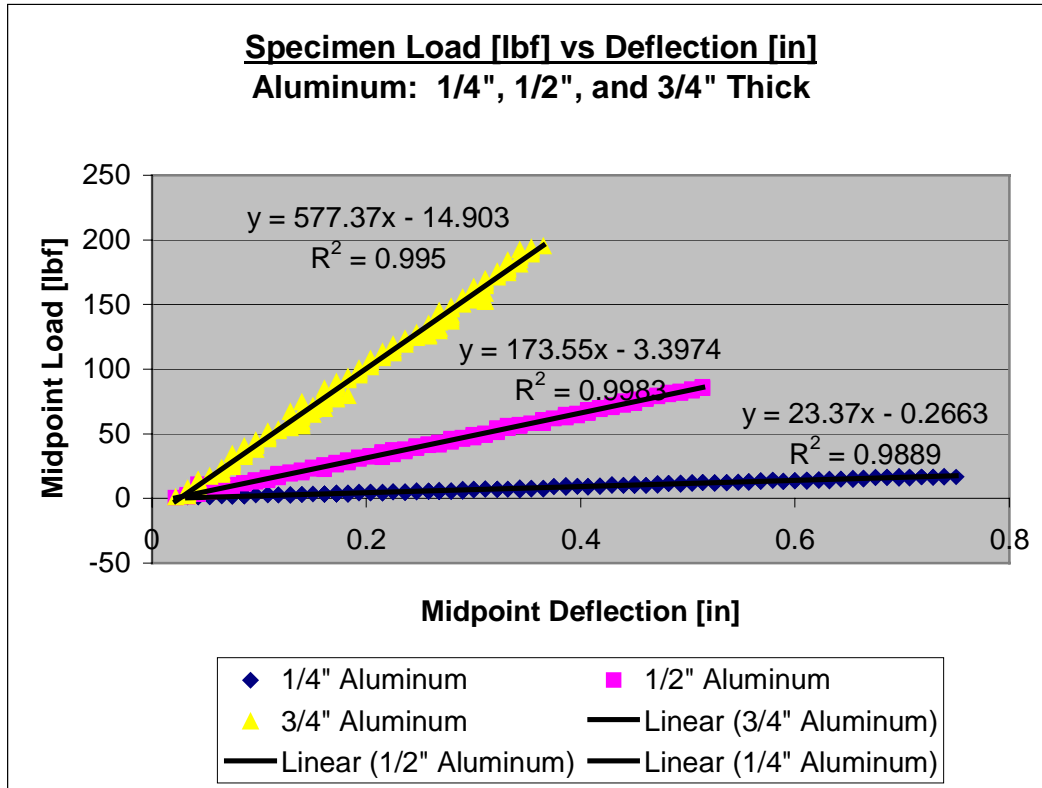

Figure 3: Raw Test Data Acquired During Test Plotted in Excel™ Spreadsheet with Regression Lines

### III. Data Acquisition in the “Old” 3 Point Bending Experiment

The previous hands-on environment included observing and hand-recording the output of the 500 lb<sub>f</sub> load cell from the display of a strain indicator and the corresponding vertical displacement of the UTM. The student teams were responsible for connecting and calibrating the strain indicator. Ten values for load and deflection were recorded at relatively uniform load increments as the beam deflected. The appropriate load increments depend upon the beam’s material and cross-section. The hand-written load and deflection data were copied and distributed to the members of the various teams, from which the individual students performed a data analysis and submitted a written report. When time permitted, students were encouraged to enter their data into a spreadsheet file for their team during the laboratory session, thus reducing the likelihood of unchecked data entry errors and speeding the subsequent analysis. This tedious recording process produced relatively few data points, introduced unnecessary error through the starting and stopping of the UTM motion, and generated many student requests for DAQ in the Recommendations Section of their laboratory reports.

### IV. Three-Point Bending Experiment with DAQ

The Three-Point beam bending experiment now relies on a LabVIEW™ virtual instrument (VI) to collect and store both load and deflection data.<sup>7</sup> The traditional instrumentation used in the experiment is retained. This ensures continuity within the strength of materials test environment, promotes understanding of how the LabVIEW™ VI operates, and provides a backup test system in case DAQ difficulties arise. Voltage signals from the UTM for deflection and strain indicator for load are transmitted into the LabVIEW™ VI shown in figure 4 for plot generation and data storage in an Excel™ spreadsheet.

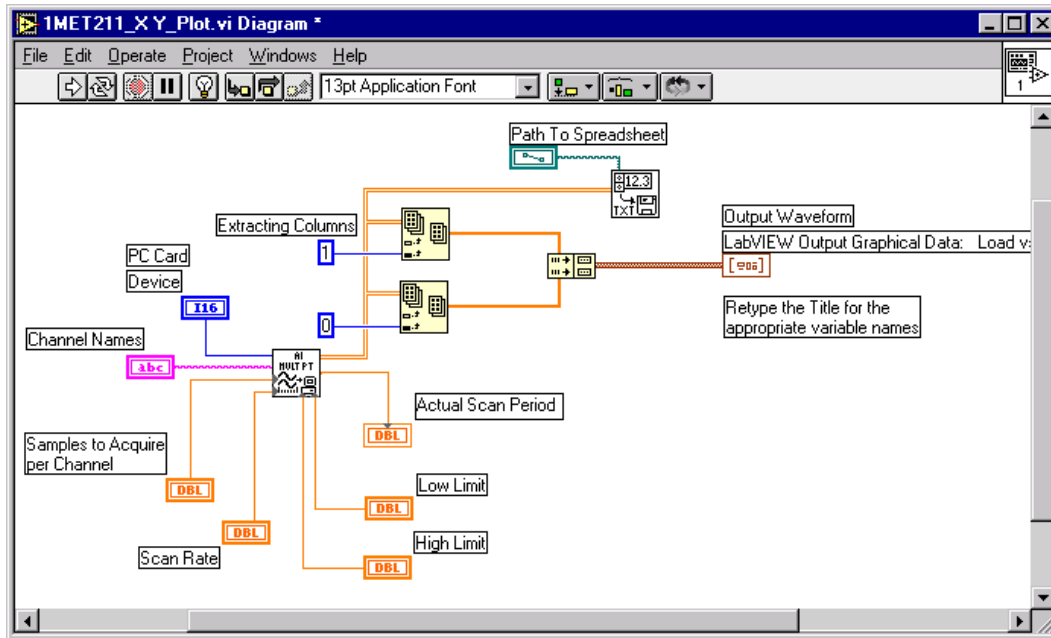

Figure 4: LabVIEW™ VI Diagram for Load vs. Deflection Plot

The VI is conceptually straightforward. When the VI is started, 200 samples of load and position data are collected, plotted on the LabVIEW front panel, and transferred to an Excel spreadsheet file for future analysis. The VI does not control the application of load to the beam specimen. Its only purpose is to serve as a data collection and storage device. Student team members must coordinate starting the UTM with starting the VI to ensure that useful data is obtained. The Load vs. Deflection front panel is shown in figure 5. The Analog Input Configuration (AIC) for the UTM's load cell is shown in figure 6 and the AIC for the UTM's crosshead ram displacement is shown in figure 7. Figure 8 shows calibration of the DAQ at the signal condition unit using a digital voltmeter (DVM). The students perform the calibration of the load cell and crosshead ram displacement. After measurements are taken, the teams input the calibration voltages into

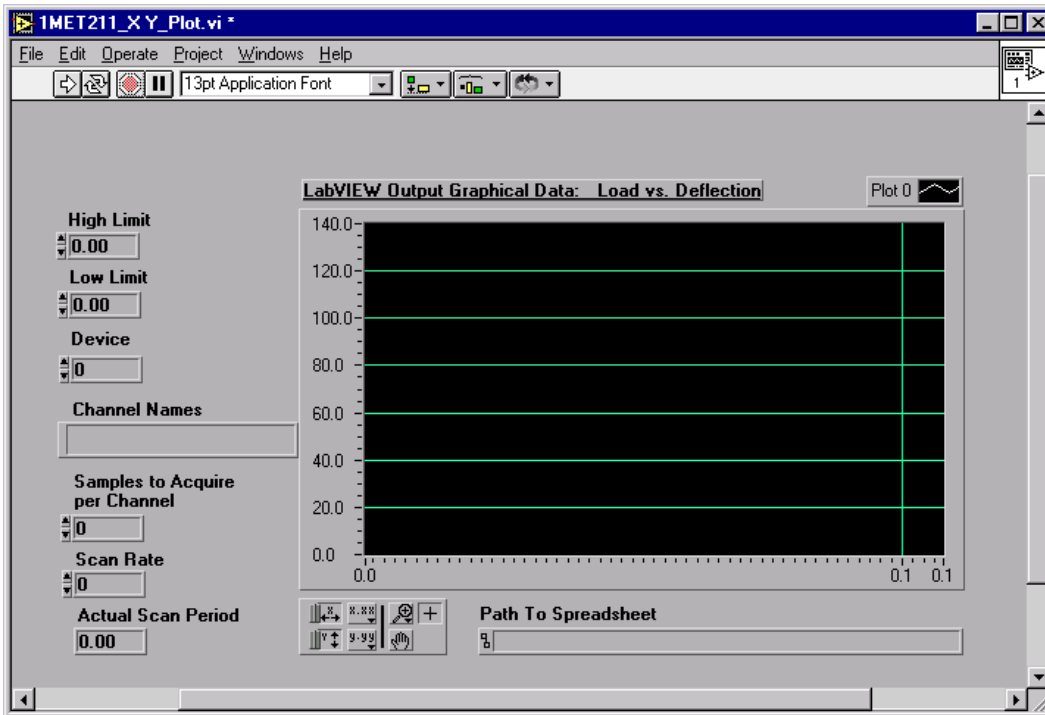

Figure 5: LabVIEW™ Front Panel for Load vs. Deflection Plot

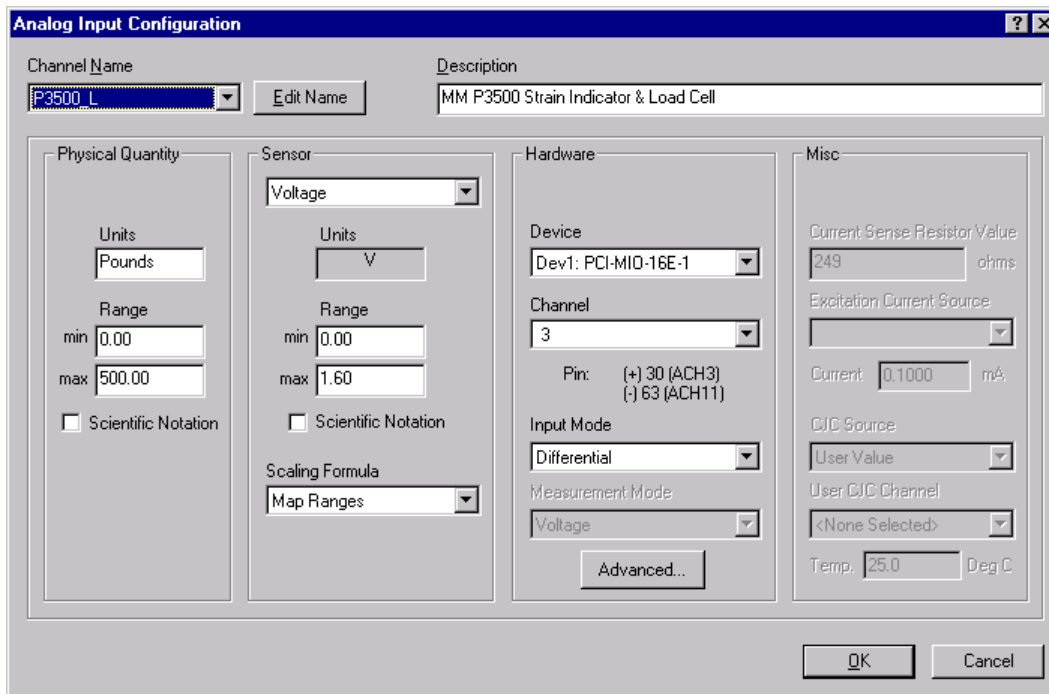

Figure 6: LabVIEW™ Analog Input Configuration for the UTM Load Cell

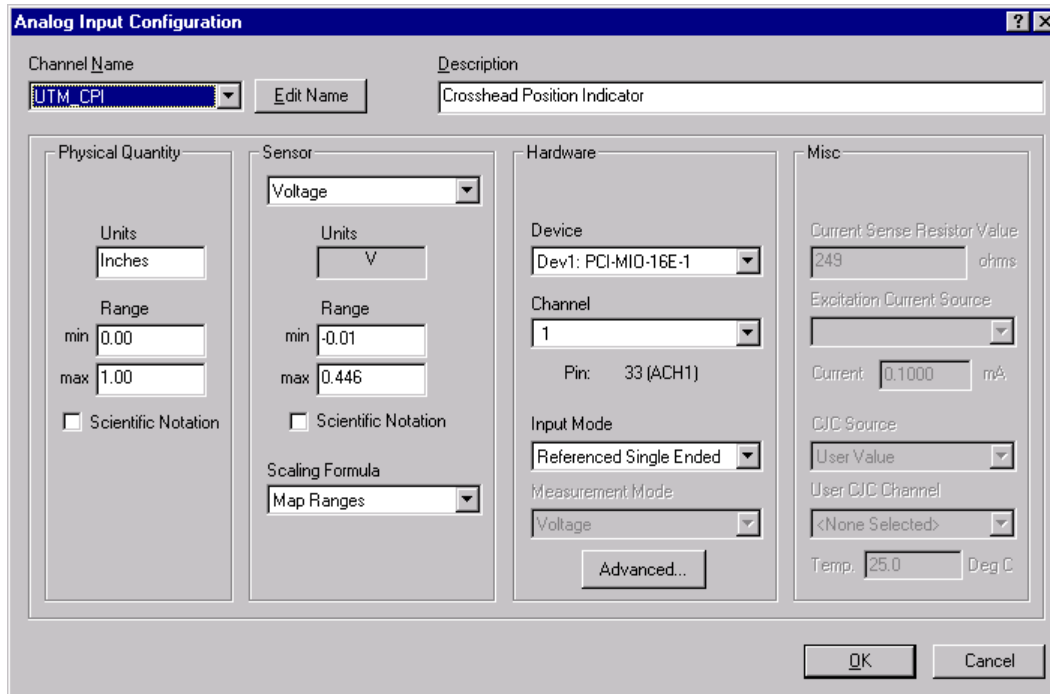

Figure 7: LabVIEW™ Analog Input Configuration for the UTM Crosshead Position Indicator

the two Analog Input Configurations within the LabVIEW™ program. These calibration tasks provide useful opportunities for the instructor to reinforce the utility and operation of the DVM itself, the necessity of careful voltage measurements, and that the transducers' output voltages are proportional to the desired load and displacement; not the actual load and displacement.

## V. DAQ Challenges

Development of any data acquisition system is likely to present unforeseen challenges. For this project, the primary challenges to overcome were extremely small voltage signals from the load/strain indicator, voltage spikes produced when the UTM stops and starts, and an analog to digital converter (ADC) that cannot simultaneously convert two data values. All of these problems could be addressed easily with sufficient funding, but the following no-cost solutions were implemented for the present:

- 1) To maximize the voltage signal from the strain indicator to the ADC, students “balance” the strain indicator to display the maximum likely load value to be obtained. With a voltmeter across the ADC terminals, the strain indicator's output gain is adjusted to its maximum, and then entered in the Analog Input Configuration screen in the NIDAQ™ software.
- 2) Each of the beam specimens was tested to find the optimum rate of travel for the UTM's crosshead ram for 20 seconds of data collection. The students adjust the ram speed accordingly. Voltage spikes are now infrequent and generally cause little effect on the



Figure 8: DAQ Calibration at the Signal Conditioning Unit

slopes of the load versus deflection curves. Data is reviewed as it is collected, and students have sufficient time to repeat testing of specimens with inordinate spiking.

- 3) A number of array-forming schemes were attempted before the correct method of bundling load and deflection data was identified. The authors chose a single plot X vs. Y graph to assure that load #1 is matched with deflection #1; load #2 is matched with deflection #2, and so forth (with a small time delay for sequential channel sampling). This array exports to Excel™ cleanly, allowing the raw data to be captured, charted, and analyzed.

## VI. DAQ Lessons Learned

The inclusion of automated data acquisition in any introductory laboratory-based course requires caution, thorough planning, and extra instructor mentoring to ensure that the benefits outweigh the potential drawbacks in the resulting learning environment. Although the most serious concerns have been addressed (as discussed below), the instructor must adjust his/her instructional approach to fit the more automated laboratory.

The fundamental purpose for the laboratory part of this course is to clarify and reinforce mechanics concepts. To ensure that mechanics concepts do not get lost in the new, often more complex instrumentation, the instructional method used should require the students to think



critically about their activities throughout the experiment. A highly interactive approach has been adopted in this course. Active instructor involvement is critical for successful DAQ experiments for several reasons. In addition to easily forcing the student teams to maintain awareness of mechanics concepts, there is the potential for minor errors resulting in no data or invalid data. Students must be fully cognizant of this potential, particularly since multiple levels of calibration are required, a new experience for most students. Requiring instructor approval at intermediate points in the setup process facilitates methodical troubleshooting and encourages the student teams to exercise caution as they prepare to collect data. An interesting observation is that several students originally thought that incorporation of DAQ techniques would make their laboratory experience easier, but were quickly reminded by their peer team members that there was plenty of work to do.

There are numerous positive aspects to inclusion of DAQ in lower division laboratory courses. From the students' perspective, the greatest benefit is the redirecting of their time from relatively mindless data collection and hand recording followed by data entry (with the possibility of typing errors generating invalid data/results) to focusing on understanding the experimental setup and mechanics concepts under consideration. From an instructor's viewpoint, the students gain familiarity with the type of test environment they may encounter in industry. They are introduced to digital signal processing constraints through common, useful applications so that they are familiar when formally presented in their later controls coursework and begin to understand the troubleshooting required to obtain good, valid experimental data.

Outside of the laboratory session, data acquisition assists as the students gain the experience of writing technical reports using integrated software packages such as MS Office™. With the availability of this capability, the increased expectation for top-quality lab reports was communicated to the students. As a result of this encouragement and making these software and hardware tools available to the students, laboratory reports are more professional in appearance than before DAQ introduction. The text of Word™ documents is enhanced through incorporation of digital photographic images taken during lab-time, captured LabVIEW™ screen shots, Excel™ raw data, and Excel™ charts created using the raw data. Very favorable feedback has been received from the students and faculty about the inclusion of animated Three-Point Bending sequences on the course web page.<sup>8</sup> These animations allow the students to “replay” certain portions of the experiment during their analysis and report-writing activities and to cut and paste the frames they deem best suited to support their laboratory report. Expecting more professional writing develops their judgment regarding information that enhances a technical report, items which simply affect appearance, and items which allow the best communication about their laboratory experiment.

## VII. Summary

The introduction of automated data acquisition into a sophomore strength of materials laboratory comes with benefits and drawbacks. With judicious lecture, homework, and laboratory support

from the instructor, the best learning aspects of the traditional laboratory are retained. At the same time, numerous new and professionally relevant educational opportunities are presented to the students through the conversion from traditional to DAQ-based experimentation.

#### Bibliography

1. Denton, N.L., Magill, M.A., Hillsman, V.S., Roach, H.R., Thelen, R.K. (2000). Strength of Materials Laboratory Manual. West Lafayette, IN: Learning Systems Incorporated.
2. Magill, M.A. (1997). "A Strength of Material Laboratory Experiment: Beam Deflection/Longitudinal Shear/Beam Stiffness." Proceedings of the ASEE IL/IN Section Conference, CD-ROM.
3. American Society for Testing of Materials. (1996). D5934-96 Standard Test Method for Determination of Modulus of Elasticity for Rigid and Semi-Rigid Plastic Specimens by Controlled Rate of Loading Using Three-Point Bending. West Conshohocken, Pennsylvania: American Society of Testing and Materials.
4. Mott, R.L. (1996). Applied Strength of Materials (3<sup>rd</sup> ed.). Englewood Cliffs, NJ: Prentice-Hall.
5. Shigley, J.E, Mischke, C.R, (1989), Mechanical Engineering Design (5<sup>th</sup> ed.), New York, New York: McGraw-Hill.
6. Roark, R.J and Young, W.C., Formulas for Stress and Strain. (6<sup>th</sup> ed.) New York, New York: McGraw-Hill.
7. National Instruments' website, <http://www.ni.com>.
8. MET 211 Course Website <http://www.tech.purdue.edu/met/course/met211/ThreePointBending.htm>.

#### NANCY DENTON, P.E.

Nancy L. Denton is an Associate Professor of Mechanical Engineering Technology at Purdue University. She regularly teaches courses in design documentation, solid mechanics, controls, and machinery diagnostics. She has chaired the Women in Engineering and Mechanics Divisions of ASEE, and currently serves as the Editor in Chief of the *Journal of Engineering Technology*, and is a member of ASME and the Vibration Institute.

#### WILLIAM K. SZAROLETTA, P.E.

William K. Szaroletta is an Assistant Professor of Mechanical Engineering Technology at Purdue University where he presently teaches solid mechanics courses. He is a member of ASEE and ASME. He has 18 years industry experience in engineering and project management positions and 6 years university teaching experience. His current applied research interests are experimental mechanics, lab automation, and optimal design using genetic algorithms.

#### LLOYD EWING

Lloyd Ewing is a mechanic in the Mechanical Engineering Technology Department at Purdue University, supporting courses in mechanics and heat power along with providing technical support for the School of Technology's stereolithography system and serving as the School's building deputy. He has over 35 years of experience in a variety of management and technical positions.