

## Arduino Controlled Irrigation System Nur-E-Afra Anika, Kabilanathan Asokan ,Bryar Pim

*Department of Engineering and Technology, Southeast Missouri State University*

### Abstract

In this era of technology, machines are used to make people's lives easier. Using this knowledge, we can improve and design simple methods of keeping people healthy. This project focuses on agriculture. By implementing technology, we can reduce manpower, time and still produce healthy organic produce. Therefore, an automatic plant irrigation system has to be designed to control different aspects necessary for plant growth. These parameters are moisture content, temperature control and light intensity. This project focuses on the results of maintaining consistent moisture, keeping the soil warm and supplying enough light to the seed/plant. This system uses an Arduino Mega microcontroller to sense moisture levels, surrounding temperature and light intensity. For example, when the moisture content is less than the limit which is predefined, it will start supplying the desired amount of water till it reaches the limit. The pump will automatically water the plant and when the soil is wet the pump will automatically switch off, thereby eradicating the need of manpower and conserving the time.

### Keywords

“Student Paper” “Arduino” “Automatic plant irrigation” “Autogarden” “Automation”

### Introduction:

Irrigation is known as artificially applying water during specific times. It can also be considered as removing water from the field by artificial means. Crops need favorable conditions to grow, and these conditions include soil moisture, temperature and light intensity. In recent years, one of the crucial challenges that the world is facing is food scarcity. With demand for food increasing due to rapidly rising population and supply not being enough, food prices have been constantly increasing. Lester Brown, an environmental analyst said in an interview to The Guardian that food is the new oil and land is the new gold.

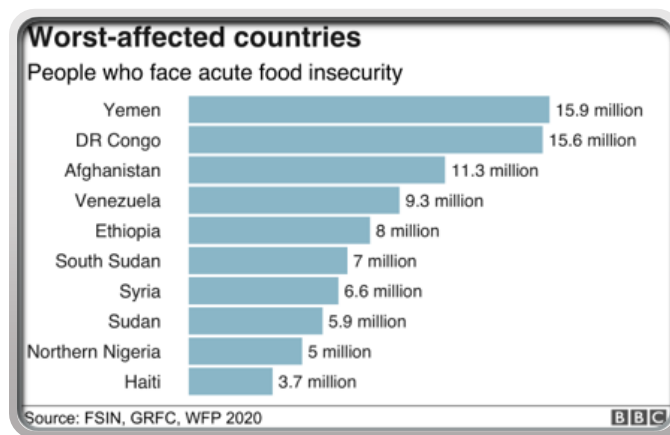

Figure 1 The chart shows the countries facing acute food scarcity in 2020

*emphasizing why tackling this issue is of utmost importance*

With more and more farmlands being used to build industrial infrastructures, production of food is lower causing supply of food to not meet the demand and eventually raising food prices. In order to come up with a solution to tackle the food scarcity and increase the production, numerous steps have been taken. One of the ways could be to come up with an innovative irrigation system that will help produce more plants if ideal conditions for plant growth is achieved. Automating the irrigation system will make sure soil moisture, temperature and light intensity is kept at a level favorable to plant growth, thus optimizing production. Maintaining soil moisture, temperature and light intensity at ideal level will ensure higher production, also reduce crop losses and make the production process more cost effective.

**Objectives:**

This project aims to tackle one of the biggest challenges the human race is facing today, food scarcity. We plan to automate the irrigation system that will assist in plant growth. We plan to monitor growth of radish seeds in controlled environment by providing the theoretically ideal soil moisture, temperature and light intensity. We aim to increase the yield of radish plants and then try our device for other crops to lower cost of production and raise yield. An automatic irrigation system will ensure better plant growth, reduce manpower required for agriculture and make plant production cost effective. With more land being used to build industries and more people engaging in tertiary sectors instead of agriculture, there is not enough land and labor to produce food for the enormous population. An automatic irrigation system will ensure that more lands could be converted to farmlands provided the ideal conditions and production could be optimized. Moreover, automation will also require less manpower and more plants could be produced with smaller labor force. In this project, we are trying to monitor plant growth by varying the conditions that affect growth of a plant. Our aim is to automate the irrigation process and control the parameters with the help of a microcontroller. We plan to build a model that will monitor plant growth as the parameters are varied and ensure a favorable environment for plant growth.

**Design Objectives:**

We plan to monitor the conditions affecting plant growth using sensors. To measure light intensity, we are using Adafruit light sensors. Soil moisture is monitored using Digi Key soil moisture sensors. Temperature and humidity sensor is bought from Adafruit. The sensors record the data and send the readings to the microcontroller, which in this case is Arduino Mega. The Bluetooth module HC05 is used to transfer the data to the app. The microcontroller is programmed to send signal to the circuit if the conditions are not favorable to optimal plant growth. For instance, if the temperature is above the optimum range, then Arduino will send signal to the fan which will turn on to decrease the temperature to the suitable range. We eventually plan to implement more features like pump to supply water if the soil moisture is below the suitable value.



Figure 2 Design Objectives

### Design Considerations:

In order to fulfill our objectives, we had to take into account technical, financial, performance, and safety aspects of our project. Our technical design considerations include the equipment we are using to build our model. For instance, in our initial design we had two power sources. The power sources we used are Mb102. The input circuit consisting of sensors are powered by one of the Mb102. The other Mb102 powers the fan. Our product will cost 300 dollars. It is significantly more economical than products like Link 4 iPonic series which costs 1641 dollars.

When we considered performance of our device, we had four main goals. Firstly, we wanted to incorporate sensors to record data. Secondly, we used the Bluetooth module to transfer data. Thirdly, the data is displayed in the app as shown in figure 1. Finally, we have a circuit that responds if the conditions for plant growth is not favorable. In order to ensure safety, we have followed the Environmental Protection Agency (EPA) regulations.

### Design Optimization:

To optimize our design, we consider the dimensions of the electronics as well as the control environment. We would like to make the electronics lightweight and take up less space as possible. The design objective for our product is to make it lightweight and portable. The user-friendly design would allow customers to place our product wherever they want. We would also like to make it Bluetooth and Wi-Fi enabled. This feature would allow the user to monitor the plant readings and keep track of the growth rate. To achieve the portability, the optimal dimensions are given as follows: 5 by 5 inch.

### Methods:

There are two major sections of our project: hardware (input, output circuit) and the software (Arduino coding). Initially, our project focused on developing the input and output circuits and testing the circuits to prove its capabilities. Firstly, we started to build a comparator circuit that will compare the reading measured from the sensors with the ideal conditions. After the readings are compared, the Arduino will send a signal to the output circuit if it has to take any necessary actions. The comparator circuit was built with a BS170 MOSFET and it was tested in Multisim to ensure that it functioned properly before we built in the lab.

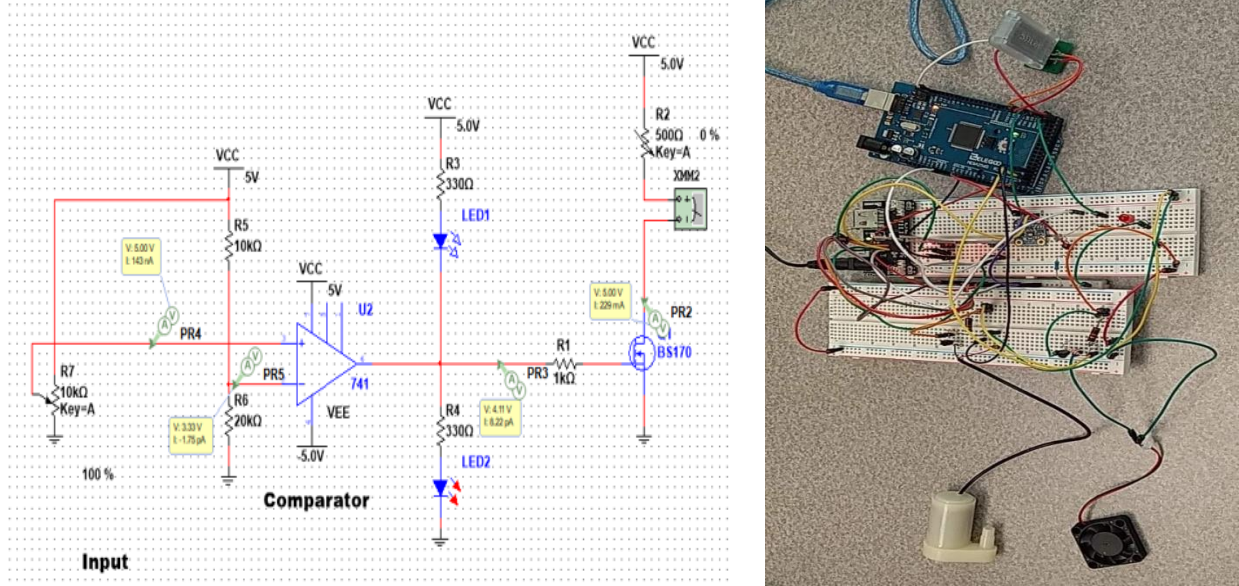

Figure 3 Circuit with BS170 tested in Multisim and circuit to test fan and pump

The circuit was tested in the lab to ensure that it works with the 200mA fan and the 100mA pump. The circuit built in the lab is shown below in figure 3.

The software part of our method includes the Arduino programming and designing an app that will help the user to monitor the conditions and update the customers if any changes occur in the parameters. The Arduino codes are shown below.

```
//Condition to control Pump
//=====//
if (SoilVal >= 150 ) {
    digitalWrite (PumpPin, LOW);
}
if (SoilVal < 150) {
    digitalWrite (PumpPin, HIGH);
}
//=====//

if(Serial1.available() > 0)
{
    Incoming_value = Serial1.read();
    palabra = palabra + Incoming_value;
    BluetoothLED_Check(); // Led to verify BTE Connected
}
}

float Fan_Control(){
    if(Incoming_value == '*'){
        palabra = palabra.substring(0, palabra.length() - 1); // Delete last char *
        //Serial.println(palabra);
        speedControl = palabra.toInt();
        //Serial.println(speedControl);
        palabra = ' ';
    }
    if( speedControl < 25){
        digitalWrite (FanPin, LOW);
    }
    else digitalWrite (FanPin, HIGH);
}
}
```

Figure 4 Activating pump and fan

The app was built to make our product user friendly. The app was built using Scratch in the MIT app inventor. The code used to make the app is shown below:

```

initialize global name to 0
initialize global Soil_Data to create empty list

when Clock1 .Timer
do
  if BluetoothClient1 .IsConnected and call BluetoothClient1 .BytesAvailableToReceive > 0
  then
    set global Soil_Data to split text call BluetoothClient1 .ReceiveText
    numberOfBytes call BluetoothClient1 .BytesAvailableToReceive
    at " "
    call TinyDB1 .StoreValue
    tag "a"
    valueToStore select list item list get global Soil_Data
    index 1
  
```

Figure 5 Sensor reading sent to app via Bluetooth

**Results:**

Our objective was to build a working model of the Arduino controlled irrigation system. We designed a PCB to make the circuit portable which is shown below in fig 6.

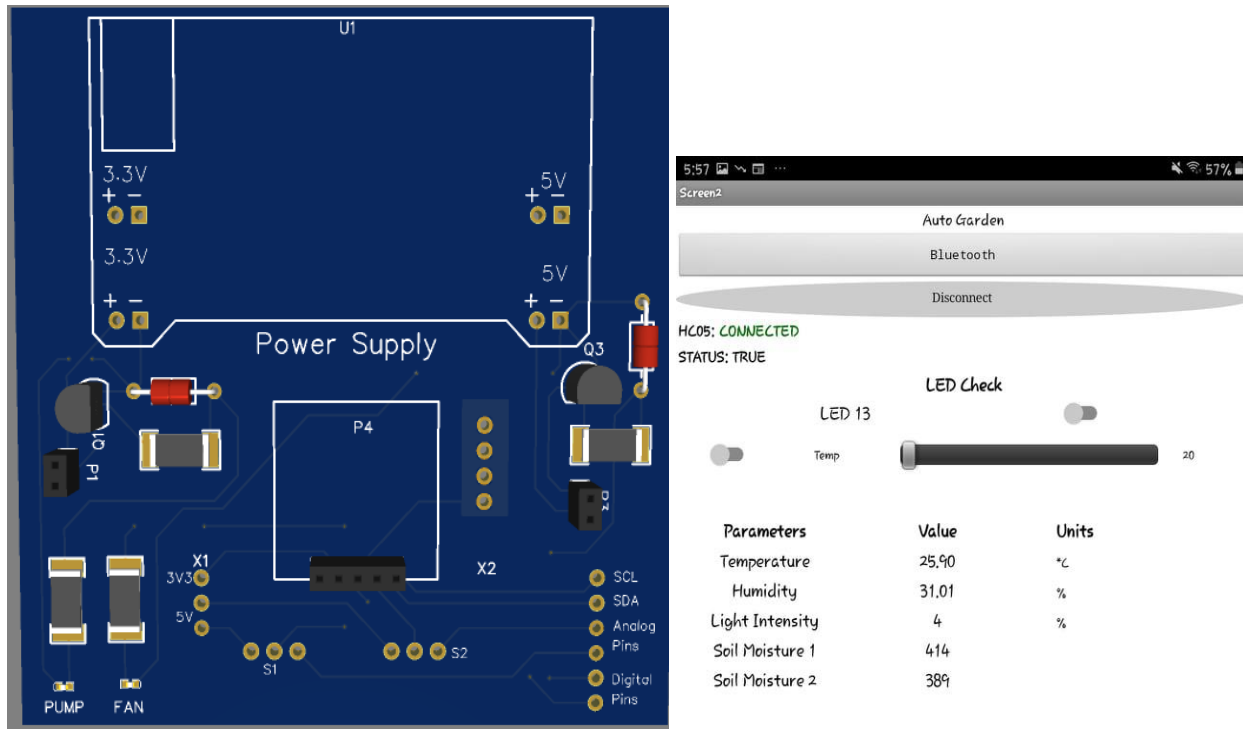

Figure 6 PCB design and App showing real time data

We also build an app that shows the temperature, light intensity, soil moisture and humidity in real time. We decided to plant a radish seed and test if our device works. The figure below shows the progress after week 2.



*Figure 4 Radish seeds after week 2*

### **Conclusion:**

In the current technological industry, machines are utilized on a daily basis in order to simplify the everyday life of people around the world. By harnessing these technological advances, the world is able to improve and produce more effective ways to maintain healthier lives. Our project, as stated, is focused on agriculture and by implementing modern technology, we are reducing labor as well as time consumption while still managing to produce the same fully organic vegetables that are produced traditionally. Our automatic plant irrigation system has been designed to control all important aspects necessary for proper plant growth such as moisture content of the soil, temperature, and light intensity. These aspects are monitored and regulated by our product via the Arduino Mega microcontroller and the programming we have produced to support the sensors. In this way, we can ensure that both time and labor of consumers will be saved and therefore produce for them a more simplified lifestyle.

### **Acknowledgements:**

We would like to thank Dr. Zhang Yumin for supervising the research. Supported by Southeast Grants and Research Funding Committee (GRFC).

## References

- [1] “Op-Amps, Comparator Circuit.” Renesas, [www.renesas.com/eu/en/support/engineer-school/electronic-circuits-03-op-amps-comparator-circuit](http://www.renesas.com/eu/en/support/engineer-school/electronic-circuits-03-op-amps-comparator-circuit).
- [2] “Operational Amplifier Summary, Op-Amp Basics.” Basic Electronics Tutorials, 19 Feb. 2018, [www.electronics-tutorials.ws/opamp/opamp\\_8.html](http://www.electronics-tutorials.ws/opamp/opamp_8.html).
- [3] “Getting Started with HC-05 Bluetooth Module & Arduino.” *Arduino Project Hub*, [create.arduino.cc/projecthub/electropeak/getting-started-with-hc-05-bluetooth-module-arduino-e0ca81](https://create.arduino.cc/projecthub/electropeak/getting-started-with-hc-05-bluetooth-module-arduino-e0ca81).
- [4] “With MIT App Inventor, Anyone Can Build Apps with Global Impact.” *MIT App Inventor / Explore MIT App Inventor*, [appinventor.mit.edu/](http://appinventor.mit.edu/).

## Author Biographies:

### Nur-E-Afra Anika

Nur-E-Afra Anika is a senior undergraduate student at Southeast Missouri State University studying Physics and Electrical Engineering. She is from Dhaka, Bangladesh. During her time at Southeast, Nur has worked as a Learning Assistant for Physics and a tutor at the Math learning center. Currently, she is a Lab Assistant for the Department of Physics and Resident Assistant for the Office of Residence Life. She served as the senator for the College of Science, Technology, Engineering and Mathematics for the Student Government Association (SGA) and is currently part of executive board for SGA. Nur aspires to pursue PhD and work in research, eventually becoming a professor so she can inspire the young minds of tomorrow.

### Kabilan Asokan

Kabilan Asokan is a fresh graduate from Southeast Missouri State University with a bachelor’s in Electrical Engineering. Kabilan is an international transfer student from Malaysia. While taking classes, Kabilan has worked at the University Center as an Event Services Manager. Currently, Kabilan is doing his OPT (Optional Practical Training) and would like to further his studies in Canada. Kabilan has been working on the “Auto Garden” capstone project since Fall 2020. He was inspired to work on this project due to his interest in gardening. Moreover, this project unites his love for farming and passion for electronics.

### Bryar Pim

Bryar Pim is a graduate of Southeast Missouri State University with a bachelor’s degree in Electrical Engineering. He is from Steeleville, Illinois. Currently, he works full-time as an engineer for Advanced Industrial Controls located in Steeleville.