

# **Assessing the Effectiveness of a Mechanical Engineering Computer-Aided Design Course**

**Roy T.R. McGrann  
Mechanical Engineering Department  
Binghamton University**

## **Abstract**

One ABET requirement is assessment and demonstration of course improvements based on that assessment. An assessment procedure that was developed for a Computer-Aided Engineering (CAE) course is presented in this paper.

The primary objective of the CAE course is to educate students in engineering design. In the course, the benefits and limitations of computer-aided engineering design and software are emphasized. A popular engineering software package (Pro/Engineer) that integrates solid modeling, simulation/kinematic analysis, and finite element analysis is used as the basis of this course.

As a means to education in design, students must first be trained to use the software. Fourteen videos were created for this course, which incorporated audio combined with PowerPoint slides. The video files (avi's) are distributed to students on five CD's. This paper briefly describes the structure of the course and how the videos are integrated.

The effectiveness of the software training and design education was assessed using a specific problem assignment that is repeated (although modified) each year. This is often referred to as a "marker problem." In this case, the assignment is an aircraft landing gear design and analysis project. A comparison of outcomes is made of results for semesters in which the videos were used without accompanying lectures with other semesters in traditional lecture format. The changes to the course that were adopted based on the assessment are presented. The assessment procedure is used to improve the quality of the course and to satisfy ABET requirements. It is proposed that this assessment procedure using marker problems can be used in other design courses.

## **Introduction**

The ability to design components and systems is recognized as one of the key characteristics defining an engineer. Design is a "systematic, intelligent process in which designers generate, evaluate and specify concepts for devices, systems, or processes whose form and function achieve clients' objectives or users' needs while satisfying a specified set of constraints."<sup>1</sup> Computer-aided engineering (CAE) software packages such as Pro/Engineer (Pro/E)<sup>2</sup> are among the modern engineering tools available to assist engineers to generate and evaluate their designs.

In this paper, we begin in the Introduction with a description of the mechanical engineering curriculum at Binghamton University. The process that we have developed in the department for continuous improvement (Departmental Course Review Process and ABET Accreditation) will be presented next. Following this will be a description of the CAE course and how it fits into the overall departmental review process.

In the second section, the assessment approach using marker problems will be introduced. The specific marker problem that is the focus of this paper will be described, as well as the rubric used to evaluate students' work on the assignment.

Results for six semesters (2002-2007) are shown in the final section. A discussion of the impact of using the pre-recorded videos is presented. In addition, the use of the marker problem results for making course improvements is shown.

## The Curriculum

Students are introduced to design and solid modeling in the first-year, introductory engineering courses that include all undergraduate engineering majors in the engineering school: mechanical, electrical, computer, industrial, and bio- engineering. In these courses, Solid Edge<sup>3</sup> is used. First-year students are also introduced to the design process through two projects. In the first semester, they perform a reverse engineering team project and, in the second semester, there is a team conceptual design project.

In the curriculum of the mechanical engineering department at Binghamton University, the Computer-Aided Engineering course (ME 481) was a technical elective until 2004-5. The course is now required in the first semester of the third year. The prerequisites for the course are the mechanics courses (statics, dynamics and solid mechanics). This course is the initial course in an upper-division four-semester design sequence. It is followed in the second semester of the third year by the course Mechanical Engineering Design (ME 392) and, in the senior year, by the two-semester capstone design sequence (ME 493/ME 494).

## Departmental Course Review Process and ABET Accreditation

ABET requires that accredited engineering programs show that their graduates attain certain abilities, understandings, knowledge and recognitions. These characteristics are listed in the document *Criteria for Accrediting Engineering Programs*<sup>4</sup> and are commonly referred to as “3(a-k).” As stated in the criteria:

“Engineering programs must demonstrate that their students attain:

- (a) an ability to apply knowledge of mathematics, science, and engineering
- (b) an ability to design and conduct experiments, as well as to analyze and interpret data
- (c) an ability to design a system, component, or process to meet desired needs within realistic constraints such as economic, environmental, social, political, ethical, health and safety, manufacturability, and sustainability
- (d) an ability to function on multi-disciplinary teams
- (e) an ability to identify, formulate, and solve engineering problems
- (f) an understanding of professional and ethical responsibility
- (g) an ability to communicate effectively
- (h) the broad education necessary to understand the impact of engineering solutions in a global, economic, environmental, and societal context
- (i) a recognition of the need for, and an ability to engage in life-long learning
- (j) a knowledge of contemporary issues
- (k) an ability to use the techniques, skills, and modern engineering tools necessary for engineering practice.”<sup>5</sup>

In the mechanical engineering department at Binghamton University, we have structured our curriculum, specifically the sequence of required courses, so that each criterion is included in more than one course and in such a way that the course instructors assigned responsibility for assessment of specific student accomplishments are clearly identified. This structure is shown in a matrix (Table I). In the matrix, shaded cells indicate that the instructor is required to collect data for ABET files. The numbers in the cells indicate the degree to which the course provides examples of student learning with respect to the ABET criteria. This could also be described as the “focus” of the course: primary, secondary, etc. For example, in ME 481, the “4” in the last, “k,” column indicates that a primary focus and assessment area in the course is to evaluate a student’s “ability to use modern engineering tools.” The fact that it is shaded means that assessment documentation should be collected, stored, and be available during the ABET accreditation review.

| Required Course                          | Course Emphasis (ABET Criteria 3) |   |   |   |   |   |   |   |   |   |   |
|--|-----------------------------------|---|---|---|---|---|---|---|---|---|---|
|  | a                                 | b | c | d | e | f | g | h | i | j | k |
| WTSN 111/112. Exploring Engineering I/II |                                   |   | 2 | 4 | 2 | 2 | 4 |   | 2 |   | 3 |
| ME 271. Engineering Mechanics            | 4                                 | 1 |   |   | 2 |   | 2 |   | 2 |   |   |
| ME 311. Mechanics of Deformable Bodies   | 4                                 | 1 | 1 |   | 2 |   |   |   | 2 |   |   |
| ME 302. Engineering Analysis             | 4                                 |   | 2 |   |   |   |   |   |   |   | 4 |
| ME 331. Thermodynamics                   | 4                                 | 1 |   |   | 2 | 1 | 1 | 2 | 2 | 2 | 1 |
| ME 273. Science of Engineering Materials | 4                                 | 2 |   |   |   |   | 4 |   |   | 2 |   |
| ME 481. Computer-Aided Engineering       | 4                                 | 1 | 4 |   | 3 |   | 3 |   | 1 | 1 | 4 |
| ME 303. Computational Methods            | 4                                 |   |   |   |   |   |   |   |   |   | 4 |
| ME 351. Fluid Mechanics                  | 4                                 |   |   |   | 2 |   |   | 1 |   |   | 1 |
| ME 372. Project Management               | 4                                 |   |   | 4 | 3 | 3 | 3 |   | 2 | 1 | 1 |
| ME 392. Mechanical Engineering Design    | 4                                 | 2 | 4 |   | 3 | 2 | 4 | 2 | 1 | 1 |   |
| ME 421. Mechanical Vibrations            | 4                                 | 3 | 3 |   | 4 | 2 | 2 |   | 2 | 2 | 3 |
| ME 441. Heat Transfer                    | 4                                 |   | 1 |   | 2 | 1 | 1 | 2 |   | 1 | 1 |
| ME 491. Instruments & Measurements Lab   | 4                                 | 4 |   | 3 | 2 | 4 | 4 |   | 2 | 2 | 4 |
| ME 424. Control Systems                  | 4                                 | 1 |   |   |   | 1 | 1 |   |   |   | 2 |
| ME 493/494. Senior Project I/II          | 2                                 | 1 | 4 | 3 | 4 | 3 | 3 | 2 | 2 | 1 | 3 |

Legend:

|          |  |
|----------|--|
| <b>4</b> | <i>Primary focus of course; ample evidence of student achievement</i>                  |
| <b>3</b> | <i>Secondary focus of course; good evidence of student achievement</i>                 |
| <b>2</b> | <i>Minor focus of course; small amount of evidence of student achievement</i>          |
| <b>1</b> | <i>Very minor coverage in the course; little or no evidence of student achievement</i> |

Table I. Mechanical Engineering Department ABET Criteria Matrix

#### The Computer-Aided Engineering Course (ME 481)

The CAE course includes both training and education. Training develops proficiency with the software. In addition, this training lays the foundation for educating students in engineering design. In the course, design education includes methodologies of design,<sup>6</sup> validation of results, and optimization through project work.

The details of the course, as well as lectures and videos, have been described in a previous paper.<sup>7</sup> In summary, the learning objectives of the course (as stated in the syllabus) are that the student should:

- (I) Develop a proficiency in solid modeling using Pro/Engineer,
- (II) Develop the ability to use Pro/Engineer as a design tool,
- (III) Be able to perform dynamic simulation using Pro/Mechanism,
- (IV) Understand the theoretical basis of finite element analysis (FEA) and perform limited, simple analysis with Pro/Mechanica Structure,
- (V) Demonstrate the integration of the elements of modeling and analysis in a CAE design project, and
- (VI) Prepare a complete design project report.

The course is structured as two one-hour lectures each week and one 2½-hour computer lab. The material presented in each of the two “lecture” sessions each week is distinct. One session consists of presentations of design methodology, engineering graphics fundamentals, kinematic and force analysis of mechanisms, and FEA. The other session consists of Pro/Engineer (Pro/E) training. The training sessions and the laboratory assignments are complementary. These training session lectures have been recorded for student self-study.

Three projects are the heart of the course comprising 54% of the grade. The remaining 46% is based on two exams (25%) and completion of the thirteen lab assignments (21%). Project #1, worth 16% of semester grade, is the creation of solid models for two parts. These are usually machine shop components that are taken from introductory drafting texts.<sup>8</sup> Examples of these parts are door bearings or automatic stop bases. An assembly model and production drawings are required in Project #2 (16% of semester grade). This assembly includes 8-10 custom parts and 3-4 standard parts. The standard parts are included online from software libraries. Students analyze the assembly for interferences. Projects 1 and 2 are intended primarily as training with the Pro/E software.

This paper focuses on Project #3: a complete engineering detail design project.<sup>9</sup> This final project is worth 22% of the semester grade.<sup>10</sup> Each semester a landing gear mechanism is selected for design and analysis.<sup>11</sup> Typically the landing gear includes a hydraulic cylinder and three links with selected contact points on the fuselage. The landing gear for Fall 2007 is shown in Figure 1. The landing gears selected can always be analyzed as four-bar linkages. Landing gear mechanisms have been used for six semesters, since Fall 2002. It is somewhat infamous among students as the “landing gear project.” An example assignment is given in the next section.

### **The Marker Problem Approach**

The landing gear project is similar to a marker problem. A marker problem is used specifically to evaluate an outcome based on a course objective. A marker problem can be a quiz, exam problem, or homework problem that is used to evaluate an outcome. The problem is used each time the course is taught to provide longitudinal assessment of student learning. In a simple case, it is a single problem. For example, in a statics course, a course objective might be “Students should be able to create and use free-body diagrams.” The marker problem could be a problem explicitly to draw a free-body diagram of a loading situation. The loading situation is changed each year, while attempting to keep the problems degree of difficulty roughly the same. If a problem on an exam or homework is used, student performance on only that one problem is tracked. The score on this one problem is then used to evaluate and track student learning. In cases where multiple outcomes are included in the solution of the problem, a grading rubric can be used where each of the items in the rubric can be paired with one of the course objectives.

In the case presented here, the marker is not an individual problem but a project assignment. Here the scoring on individual items in the rubric is used to evaluate student learning. These items are matched to corresponding course objectives as stated on the syllabus. The assignment and the grading rubric are presented below.

Marker problems provide a direct measurement of student learning. Marker problems are used in all of the courses in the mechanical engineering department in which collection of assessment data is required by our ABET Criteria Matrix (Table I).

#### **The ME 481 Project #3 Assignment (Marker Problem)**

As an example of a marker assignment, the project assignment for Fall 2007 is given here:

“Design and analyze the landing gear assembly shown in Figure 1.

1. Create the seven components and five pins as parts using Pro/E. Use the dimensions given on the drawings provided. Note: these dimensions are approximate dimensions only. Design the final dimensions so that there are no improper interferences in the assembly. Changes cannot be made to the plan-view location of the ground points (D, A), the dimensions of the tire and wheel, the location of the slot ( $d-d'$ ) or the vertical distance from D to the center of the axle in the down position, as shown.
2. Create the assembly and two sub-assemblies (piston/cylinder and wheel/tire) in Pro/E.
3. Create the Pro/E material (.mat) files.
4. Build a dynamic simulation model using Pro/Mechanism. (a) Determine the forces at the pins and axle for the complete range of input. (b) Check your work with a graphical kinematic analysis of the four-bar linkage.
5. Perform finite element analysis using Pro/Mechanica Structure:
  - (a) Determine the maximum stresses and give the associated factors of safety of each pin, including the connections to the frame, and (b) perform convergence analysis and verification/validation calculations for each of your results.
6. Submit a formal report (hardcopy and CD) including analysis of the stresses (maximum and factor of safety) for each required component. Include in this document: (a) graphs of force vs. cylinder displacement for each item in (5), (b) von Mises stress distributions on each component, (c) the kinematic analysis (4b), and (d) all convergence graphs and verification cases (5b).<sup>12</sup>

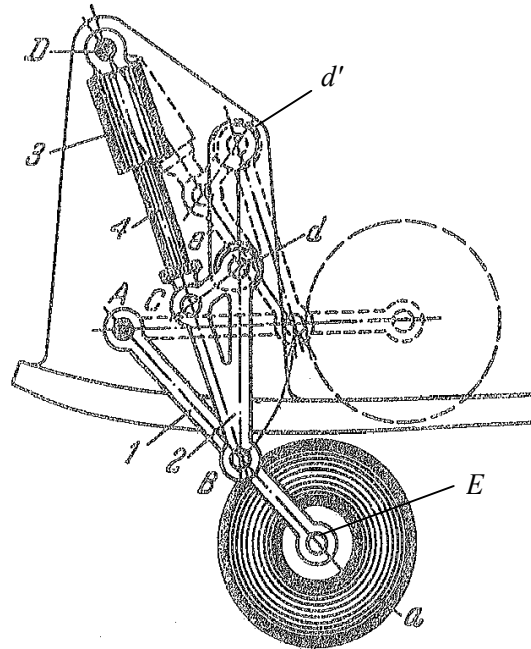

Figure 1. Landing Gear 2007

As can be seen there are many tasks involved in this design project. When the reports are graded, a grading rubric is used to identify the items to be evaluated based on the assigned tasks. In addition, this rubric relates the individual items to course objectives. The grading rubric is shown as Table 2. This rubric has been employed since the offering of the course in 2004.

Two areas of the assignment have been selected for presentation in this paper. One is the report itself, identified in the rubric in the Engineering communication section. As shown in the rubric, this corresponds to course objective VI (Prepare a complete design project report). The other area is FEA. There are three items involving FEA: FEA of Stress, FEA Convergence, and FEA Validation. One point of emphasis during lectures is the notion that “FEA makes a good engineer better, and a poor engineer dangerous.”<sup>13</sup> In addition to the contour plots of the von Mises stress on the pins in the mechanism, students are required to create convergence diagrams, using strain energy as the measure, for each of their stress analyses. Lastly, because simulations are models and involve many simplifications and assumptions, the requirement that they must verify FEA results with experimental examples is emphasized. In this case, because they do not have access or time to perform full-scale or laboratory tensile tests, they must perform a “validation study” in which they create an additional finite element analysis of one of their pins using a loading for which they can hand-calculate the stress results. These must then be compared to the FEA results from Pro/Mechanica. These three items (plots, convergence, validation) are used to evaluate course objective IV (Understand the theoretical basis of finite element analysis and perform limited, simple analysis with Pro/Mechanica Structure).

In terms of our ABET Criteria Matrix (Table I), data collection is required in this course for two of the ABET a-k abilities: (c) - an ability to design a system, component, or process to meet desired needs within realistic constraints such as economic, environmental, social, political, ethical, health and safety, manufacturability, and sustainability) and (k) - an ability to use the techniques, skills, and modern engineering tools necessary for engineering practice). As this is a design project, the overall score on the project, can be used as an indicator of design ability ABET (3c). To reinforce this data, in addition to providing a direct measure of ABET 3g (an ability to communicate effectively), the score on the report itself (under Engineering Communication in the rubric) is used as an indicator of design ability.

Finite element analysis using Pro/Mechanica Structure is one of the tools available to contemporary engineers. To evaluate student ability to use modern engineering tools (3k), the items involving FEA are examined.

|                                   | Item                              | Objective Number | Max. Points | Points Given |
|-----------------------------------|-----------------------------------|------------------|-------------|--------------|
| Solid Model and Motion Simulation | Parts Complete                    | I                | 10          |              |
|                                   | Mechanism Execution               | III              | 10          |              |
|                                   | Interferences                     | II               | 5           |              |
| Engineering Analysis              | Design Detail                     | I                | 5           |              |
|                                   | Motion Driver Specification       | III              | 5           |              |
|                                   | Graphs (Force vs. Displacement)   | III              | 5           |              |
|                                   | Four-bar Linkage Analysis         | V                | 10          |              |
|                                   | FEA of Stress                     | IV               | 5           |              |
|                                   | Loads and Constraints Appropriate | II               | 5           |              |
|                                   | FEA Convergence                   | IV               | 5           |              |
|                                   | FEA Validation                    | IV               | 5           |              |
|                                   | Factors of Safety                 | II               | 5           |              |
| Engineering Communication         | Report                            | VI               | 10          |              |
|                                   | Drawings                          | I                | 5           |              |
| Overall Evaluation                | Discretionary                     |                  | 10          |              |

Table II. Project #3 Grading Rubric

Each student's project is graded using this rubric and the scores entered in a spreadsheet. The scores for all students are then analyzed. The achievement of course objectives are traceable based on this analyzed data. This analysis is used in the course evaluation feedback process to identify where improvements are needed and to make any identified changes. These are documented and reviewed by the faculty at a course review session during one of the department meetings during the semester following that in which the course was offered. Results are presented and the process is described in the next section.

### Results and Discussion

Data from six semesters (2002-2007) of the course is shown in Table III. Use of the grading rubric described above was begun in 2004. Only required courses are included in the departmental ABET criteria matrix. This course was made a required course in 2005. Prior to and including that year, the course was a senior elective. As can be seen from the row in the table labeled "Level," in 2005 seniors took the course as an elective and juniors took it as a required course. Their results are presented separately, although no distinction during the course offering was made. In the six years the course has been offered, two versions of Pro/E have been used: Pro/E 2001 was used 2002-2005. Wildfire 3.0 has been used since 2006. Recorded lectures were available only for Pro/E 2001 in 2004 and 2005. The arithmetic average, sample standard deviation, and median are reported for the overall score in the

course, the landing gear project score, the written project report score, and the three FEA rubric items (stress contour plots, convergence, and validation).

### Analysis of Overall Course Scores and Impact of Using Video Lectures

As expected, there was a decrease in the course average and an increase in the standard deviation after the course became a required course and juniors instead of seniors were enrolled. There does not appear to be much effect of using recorded videos. Relative to previous years, the course average decreased when the videos were used in 2004 and 2005. However, the average remains at approximately that level later when the videos were not used (2006, 2007). Thus, the decrease is possibly attributable to the course demographics (juniors instead of seniors) rather than the use of the recorded videos. One interesting difference is seen when comparing the junior with the senior scores in 2005, a year in which the videos were employed. The seniors' average and median was higher than the juniors', indicating that the seniors were using the videos in a more effective manner than the juniors. This is not statistically clear however, due to the large standard deviations. It does reinforce previous work by Fellows, et al. that results to be gained from self-study correlates more with maturity as measured on Perry's<sup>14</sup> hierarchy than with intellectual ability.<sup>15</sup>

|                       |                           | Year       | 2002  | 2003  | 2004  | 2005  |       | 2006  | 2007  |
|-----------------------|---------------------------|------------|-------|-------|-------|-------|-------|-------|-------|
|                       |                           | Enrollment | 31    | 33    | 43    | 24    | 74    | 96    | 84    |
|                       |                           | Level      | SR    | SR    | SR    | SR    | JR    | JR    | JR    |
|                       |                           | Pro/E Ver. | 2001  | 2001  | 2001  | 2001  |       | WF3   | WF3   |
|                       |                           | Videos     | No    | No    | Yes   | Yes   |       | No    | No    |
| Course Score<br>(100) |                           | Avg.       | 89.30 | 87.90 | 85.10 | 83.95 | 75.80 | 82.50 | 83.70 |
|                       |                           | Std. Dev.  | 3.60  | 5.10  | 6.30  | 7.39  | 13.28 | 11.60 | 11.40 |
|                       |                           | Median     | 89.30 | 89.20 | 85.90 | 83.66 | 77.00 | 85.70 | 86.00 |
| Project #3            | Project<br>Score<br>(100) | Avg.       | 84.80 | 85.40 | 80.40 | 68.34 | 74.73 | 74.10 | 81.20 |
|                       |                           | Std. Dev.  | 8.50  | 9.90  | 16.40 | 18.37 | 15.98 | 20.40 | 24.36 |
|                       |                           | Median     | 85.00 | 88.00 | 84.00 | 62.00 | 77.00 | 77.00 | 87.00 |
|                       | Report<br>Score<br>(10)   | Avg.       |       |       | 4.50* | 6.26  | 6.24  | 6.24  | 6.15  |
|                       |                           | Std. Dev.  |       |       | 3.10* | 2.95  | 2.43  | 2.75  | 1.84  |
|                       |                           | Median     |       |       | 5.00* | 7.00  | 7.00  | 6.00  | 7.00  |
|                       | FEA<br>Stress<br>(5)      | Avg.       |       |       | 4.12* | 4.35  | 4.33  | 4.68  | 4.61  |
|                       |                           | Std. Dev.  |       |       | 1.71* | 1.39  | 1.50  | 1.13  | 1.38  |
|                       |                           | Median     |       |       | 5.00* | 5.00  | 5.00  | 5.00  | 5.00  |
|                       | FEA<br>Conver.<br>(5)     | Avg.       |       |       | 2.58  | 3.91  | 3.96  | 4.67  | 4.69  |
|                       |                           | Std. Dev.  |       |       | 2.00  | 1.42  | 1.21  | 1.20  | 2.81  |
|                       |                           | Median     |       |       | 2.45  | 5.00  | 5.00  | 5.00  | 5.00  |
|                       | FEA<br>Valid.<br>(5)      | Avg.       |       |       | 0.81  | 1.00  | 1.52  | 2.80  | 3.69  |
|                       |                           | Std. Dev.  |       |       | 0.00  | 1.77  | 1.80  | 2.29  | 2.21  |
|                       |                           | Median     |       |       | 1.87  | 0.00  | 0.00  | 2.00  | 5.00  |

Table III. Data: ME 481 Course and Project #3

(\* These scores were extrapolated from a preliminary rubric that is not identical to Table II.)

### Analysis of Project Scores and Report Scores

The Project Score and the Report Score are used as indicators of student ability to design a mechanism, in this case, the landing gear. These scores are presented in Figure 2. The scores are separated for juniors and seniors. The Project Scores for seniors show a slight drop in the third year that the course

was offered and a drastic drop for the fourth year (2005). We believe this is due to both the quality of students (note the slight drop in course average for seniors compared to previous years) as well as, the mixed junior-senior class that year. The Project Scores for juniors show a slight drop in the second year and marked improvement for the third year (2007). Report scores for both the seniors and juniors are relatively unvarying for the four years of data shown.

As the trends for the two measures (Project and Report) are different, the question becomes which is the better indicator of design ability. The unchanging report scores indicate that students writing ability has remained constant. The increasing scores for the project, it is believed, represent an improvement in design learning.

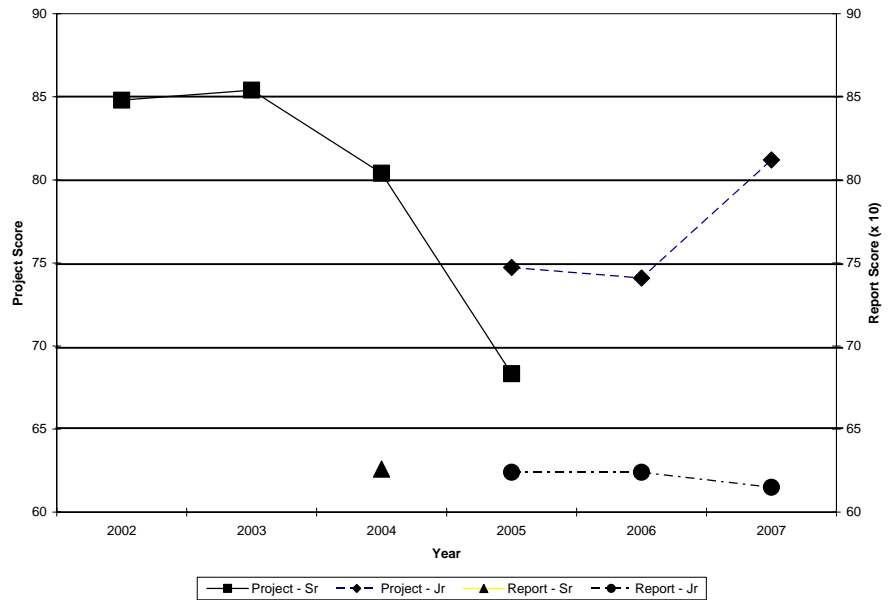

Figure 2. Project Scores and Report Scores

#### Analysis of FEA Scores

Figure 3 shows the trends in the scores on the FEA items in the rubric. As there is not a significant difference in 2005 between junior and senior scores on these items, they have been averaged for the figure.

From Figure 3, it can be seen that from the time the course was first taught students had little trouble creating contour plots. It is also apparent that there was poor understanding on the part of students regarding both convergence and validation. In subsequent years, changes were made in both the content and emphasis of the FEA lectures and, also, the requirement for convergence analysis and validation were made more explicit in the wording of the project assignment. These resulted in improved student performance, although further improvement is still required.

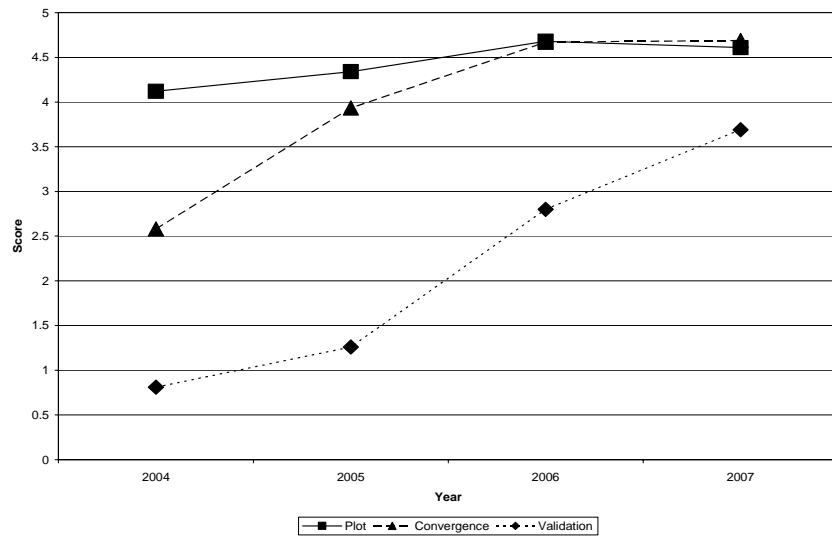

Figure 3. FEA Scores



## ABET Documentation

This marker project assignment provides a useful measure of student learning and a reference for gauging the effect of any changes that are made. In addition to course improvement function, the assignment is used as part of the documentation for ABET. A record is kept of previous and proposed changes to the course. An example is shown in Figure 4. The example shown in the figure is part of the document from Fall 2005. In the figure, the portion for 3(k) is not shown but those results are described with 3(c). The instructor each time a course listed in the Mechanical Engineering Department ABET Criteria Matrix is offered completes one of these documents.

### ME Actions Based on Course Assessment ABET Course Documentation

ME 481 CAE

Semester: Fall 2005

Instructor: McGrann

**Note: This is the first offering of this course as a required course in the ME curriculum. Class includes both juniors who are taking the course because it is required and seniors who are taking it as an elective.**

| The program outcomes for this course emphasize student learning in:           | Actions taken in response to previous assessments  | Recommended changes based on end-of-semester assessment                                       |
|---|--|---|
| a) an ability to apply knowledge of mathematics, science and engineering      | No changes.  | No changes.   |
| c) an ability to design a system, component, or process to meet desired needs | Lecture on FEA included more discussion of convergence and validation. Examples used were clarified. | Change Lab 11 report to include written discussion of convergence and validation by students. |

Figure 4. Documentation: Actions Based on Course Assessment

## Conclusion

The characteristics of this landing gear project make it especially useful as a marker problem. The particular geometrical arrangement of the components is different each year, providing an interesting and challenging project for students. The grading rubric is well structured and relative easy to use.

The assessment process implemented in the Mechanical Engineering Department at Binghamton University links the ABET 3(a-k) criteria to courses using the Department ABET Criteria Matrix (Table I). The course objectives, from the syllabus, of each course are then tied to this matrix. Any required documentation is also identified in the matrix. Marker problems (such as Figure 1) map directly to course objectives. Student performance on these marker problems is recorded (Table 2 and Figures 2 and 3) and evaluated by the instructor and the department faculty each semester. Changes to the course based on assessment are documented (Figure 4). This process provides a structure to identify problems of student learning and eases the preparation of documentation for ABET accreditation.

The continuous improvement process of assessment using a direct measure of student learning, feedback adjustment, and re-assessment has been implemented using a marker assignment. The marker problems discussed in this paper are repeatable assignments that provide a consistent basis for longitudinal evaluation of the effectiveness of design education and that are used to satisfy ABET requirements.

## Biographical Information

Roy T. R. McGrann, Ph.D.

Professor McGrann is the Director of the Engineering Design Division and an Associate Professor in the Mechanical Engineering Department at Binghamton University – SUNY. Dr. McGrann currently teaches the undergraduate courses: Computer-Aided Engineering and Mechanical Engineering Design. In addition, he is responsible for the introductory courses for all first-year engineering students:

Exploring Engineering I & II. For fifteen of the years prior to accepting his academic position, he was engaged in steel production and fabrication. He has been associated with the Navy Joining Center (Columbus, OH) and worked in the petrochemical industry. His responsibilities included production management, machine design, project engineering, engineering management, consulting, and executive management. He has served or is currently serving on several national standards committees including ASTM, ANSI/AWS, and MSS committees. During this time, Dr. McGrann maintained his registration as a Professional Engineer (PE). He is the Binghamton University Campus Representative for ASEE and the faculty advisor for the student sections of ASME and SAE. He has served as an ABET PEV for ASEE. He is also a member of several other professional societies including IEEE/RAS, TSS/ASM-International, AWS, and SHOT.

---

<sup>1</sup> Dym, Clive L., et al., "Engineering Design Thinking, Teaching, and Learning," *J. Engineering Education*, 94:1 (Jan., 2005), p. 104

<sup>2</sup> Parametric Technology Corporation (PTC), <http://www.ptc.com/>, accessed 10 February 2008.

<sup>3</sup> Siemens Product Lifecycle Management Software Inc., [http://www.plm.automation.siemens.com/en\\_us/products/velocity/solidedge/index.shtml](http://www.plm.automation.siemens.com/en_us/products/velocity/solidedge/index.shtml), accessed 10 February 2008.

<sup>4</sup> ABET Criteria for Accrediting Engineering Programs: Effective for Evaluations during the 2008-2009 Accreditation Cycle, <http://www.abet.org/Linked Documents-UPDATE/Criteria and PP/E001 08-09 EAC Criteria 11-30-07.pdf>, accessed 10 February 2008.

<sup>5</sup> Ibid., p. 2.

<sup>6</sup> The methodology that is taught is based on Dixon, John, and Corrado Poli, *Engineering Design & Design for Manufacturing: A Structured Approach*, Field Stone Pub (1999) and Eggert, Rodolph J., *Engineering Design*, Prentice Hall (2004)

<sup>7</sup> McGrann, R.T.R., "Enhancing Engineering Computer-Aided Design Education Using Lectures Recorded on the PC," *Journal of Educational Technology Systems*, Fall 2006

<sup>8</sup> Giesecke, Frederick E., et al., *Technical Drawing*, 7<sup>th</sup> Ed. (New York, NY: Macmillan Publishing Co., 1980)

<sup>9</sup> Dym, op. cit., p. 111

<sup>10</sup> The percentage of the semester grade that is allocated for this project has changed in the six years the course has been offered. When the course was an elective course (2002-2004) there was an additional Project #4 that was an individual project usually tied to the capstone project that students took at the same time as this course.

<sup>11</sup> Artobolevsky, Ivan I., *Mechanisms in Modern Engineering Design, Vol. II, Lever Mechanisms, Part 1*, trans. Nicholas Weinstein (Moscow: Mir Publishers, 1976)

<sup>12</sup> ME 481 Syllabus, Fall 2007

<sup>13</sup> Toogood, Roger, *Pro/Engineer Wildfire 3.0 Mechanica Tutorial (Structure/Thermal)*, (SDC Publications, 2006).

<sup>14</sup> Perry, W. G., *Forms of Ethical and Intellectual Development in the College Years: A Scheme*, Holt, Rinehart, & Winston, NY, 1970.

<sup>15</sup> Fellows, Sharon, Richard Culver, William Beston, "Keys To Success: Self-Directed Learning," *Proceedings of the 2000 ASEE Annual Conference & Exposition: Engineering Education Beyond the Millennium*; St. Louis, MO; USA; 18-22 June 2000.