

Bi-Use Wheelchair/Examination Table

Thomas Boronkay, Janak Dave, Erika Shafts

University of Cincinnati

Abstract

Students working toward the Baccalaureate degree in Mechanical Engineering Technology (MET) at the University of Cincinnati are required to complete a Design, Build & Test Capstone design project. Some of these projects are geared to meet the needs of the local non-profit organizations that provide community service. For the past several years, the MET department has been working with these organizations to identify problems to be solved by senior students. The current focus is on improving the quality of life for the elderly and people with physical disabilities.

Doctors and nurses examining wheelchair bound patients state that in order to minimize the risk and discomfort to the patients as well as the risk to the healthcare professionals, a better method to shift these patients from the wheelchair to an examination table should be devised.

This paper describes a project solving this problem from concept to final working prototype. The practical solution was a bi-use wheelchair, which can function as a wheelchair, then will convert to an examination table that rises to the proper height.

Introduction

Wheelchair bound patients typically have a limited range of mobility. This makes it difficult to get them onto an examination table for diagnostic purposes. In many instances, it is necessary for them to be examined in a horizontal position for at least a part of the examination. Usually, the health care professional must physically lift the patient onto the examination table. This causes physical stress on both the patient and the healthcare worker. In addition, many doctors and nurses will not place a wheelchair bound patient onto an examination table because of legal liabilities. They may examine the patients while sitting in the wheelchair. This is uncomfortable for both the patient and the examiner and may result in incomplete or erroneous diagnosis. Healthcare professionals, who were consulted, suggested that a device addressing the above need would be beneficial. This paper describes a Senior Capstone Design project resulting in a prototype of the "Bi-Use Wheelchair" to help meet patients' and examiners' needs.

Design

Research of current literature and equipment showed no products satisfying the above need. The closest one, "Gerri-Chair" is a lazy boy-type reclining chair with four very small wheels.

Discussions with nurses in the field revealed that this type of chair is never used to transport a patient outside of a building, because the small wheels do not transition well over or around obstacles and because of the lack of space for a wheel lockdown in a van or bus. The other limitations of this chair are that even in the reclined position, it simply tilts back keeping the same basic shape of a 90° seat and it does not lift to the proper height for an examination.

The above needs were met by redesigning an existing wheelchair, so that it can function as an examination table at proper height. This conversion can be easily done by a healthcare provider.

Customer Needs

The two primary customers of this product are health care professional and wheelchair bound patients. Surveys and personal interviews with hospital and nursing home personnel were used to obtain the “Voice of the Customer”. Some of the needs articulated by the customers were: Ease of conversion, safe and simple to use, and affordability among others.

Product Specifications

The above needs were used in developing the “House of Quality” which in turn is used to convert these needs into quantified design specifications. These were: time of conversion, manual force of conversion, angle of reclination, height of chair in the “Examination Table” configuration, and number of people required for conversion. (Fig 1)

	Fast conversion time	Number of operators	Smooth conversion	Force to convert	Degree from horizontal	Cost	Height of "exam table"	Customer importance	Physically moving patient	New converting chair	Sales point	Improvement ratio	Modified importance	Weighted importance		
Performance																
Sturdy			3		3		9	4	1	5	1.0	5.0	20.0	0.30		
Easy to maintain		1	1			1		3	1	3	1.0	3.0	9.0	0.14		
Easy to convert	3	9	3	9			3	4	1	4	1.0	4.0	16.0	0.24		
Simple to use		3						4	3	4	1.0	1.3	5.3	0.08		
Features																
Affordable						9		2	5	4	1.0	0.8	1.6	0.02		
Appearance							1	1	1	2	1.0	2.0	2.0	0.03		
Safe to use	9	3	3	3	1		9	5	2	5	1.0	2.5	12.5	0.19		
Less stress on patient		3	3		9			4	2	4	1.0	2.0	8.0	0.12		
Technical Importance	2.4	3.47	2.69	2.73	2.18	0.35	5.16								66.4	1.0
Competitive Analysis																
Physically moving patient	1.0	4.0	1.0	5.0	1.0	5.0	1.0									
Target Value	4.0	5.0	3.0	5.0	4.0	5.0	3.0									
Units	min	#	in/s ²	lb	deg	\$	in									

Figure 1 House of Quality

Design Standards

The final product satisfies the Rehabilitation Engineering and Assistive Technology Society of North America (RESNA) [1] standards for wheelchairs. The basic standards include the general shape, standards on wheelchairs seating in motor vehicles, and SAE restraint standards. The ANSI/RESNA standards are based on ISO standards for wheelchairs. ISO 16840 and the corresponding RESNA 16840 were followed in this project.

Human factors were also essential to the design process. These factors determined the overall size of the individual components and the size of the structures making up any part that would have to support a load. The prototype was designed to a 99th-percentile male weighing 244 pounds and standing 75.6 inches [2]. The maximum force acting on each part of the chair was determined using data from Table 1 [3]. The prototype wheelchair will require modifications to accommodate patients who fall outside the 99-percentile group.

Body Parts	% of Total Weight
Head	6.9
Trunk and neck	46.1
Upper arms	6.6
Lower arms	4.2
Hands	1.7
Upper legs	21.5
Lower legs	9.6
Feet	3.4

Table 1. Body Parts' Total Weight

Selection of Best Design

Three alternative design concepts were generated and the “Best” one was selected using the Pugh method. The Pugh method [4] compares each competing concept to a known datum, based on design criteria. For this project the datum was physically picking up the user and moving him or her from the wheelchair to the examination table (Table 2).

Criterion	Recline Scissor Style	Style	Wider Base Style	Physically moving patient
Sturdy	+	+	+	D
Easy to maintain	S	S	S	
Easy to convert	+	S	S	A
Simple to use	+	+	+	
Affordable	- -	-	T	T
Appearance	+	+	+	
Safe to use	+	+	+	U
Less stress on patient	+	+	+	M
Σ+	6	5	5	
Σ-	1	1	1	
ΣS	1	2	2	

Table 2. Pugh's Concept Selection Method

Detail Design

The functional requirement of the chair indicates two operations: raising and lowering and tilting to a horizontal position. These operations may be controlled by two independent devices. The frame, reclining and lifting mechanisms, and the necessary controls were designed and analyzed as sub-systems.

Frame

The design process began by analyzing an existing wheelchair frame. No modification was required due to the shift in the center of gravity when converted to an examination table. Using the 99th-percentile male, the maximum change in the location of the center of gravity was only 1.7 inches [2]. Even with this shift the chair remained stable.

The standard wheelchair frame had to be modified to allow for the backrest and the footrest to move. Since the standard wheelchair is close to the ground, the footrest was too short to support the patient's legs in the examination position and the need for larger rotation of the footrest. Therefore it is not considered a part of the modified frame. (Fig. 2) The redesigned frame was designed using a factor of safety of 2. The selected frame material is 7/8 inch, chrome plated, steel tubing.

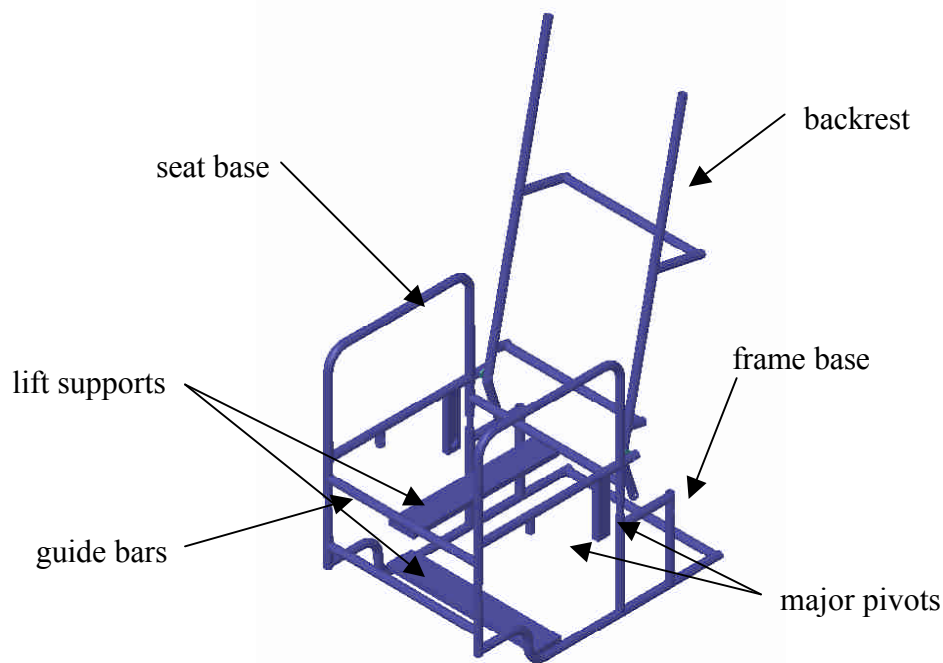

Figure 2 Frame

Reclining Mechanism

The mechanism used for reclining the wheelchair has nine links, including the backrest and footrest. On a standard wheel chair the footrest is a part of the frame. Layouts for the footrest and backrest portions of the system are similar to a “Lazy Boy” recliner. The

linkage was designed using the “Working Model” simulation software. In the upright position, the backrest sits 12° off of the vertical and the footrest at 28° of the vertical. In the reclined position, the backrest sits 26° off of the horizontal and the footrest at 14° of the horizontal. Figures 3 & 4 depict the chair in both configurations.

Weights of the head, torso, upper arms, and neck were combined into one resultant force acting on the backrest. Likewise, weights of the lower legs and feet were combined into resultant force acting on the footrest. Stress calculations yielded a bending stress of 16150psi and a shear stress in the pins of 9975 psi. Based on this analysis, the final linkage design has a factor of safety of 2.

Hydraulic System

A single speed hydraulic hand pump and two pneumatic cylinders fitted with special seals to operate at low hydraulic pressure were chosen to lift and recline the wheelchair. The maximum operating pressure is 162 psi. One of these cylinders performs the reclining motion and the other the lifting motion. The lifting motion follows the reclining motion. The hand pump displaces 0.160 in³ of oil per stroke of the handle and has a usable oil capacity of 20.3 in³. Both cylinders have 1.5 in. bore and 5 in. stroke.

In addition to the stress analysis and fulfilling the performance requirements, DFA (Design for Assembly) principles were used throughout the design process resulting in fewer parts.

Fabrication

All of the materials for fabrication of the prototype were either purchased or donated. The chrome plated frame material was cut up into the correct sizes and welded together using the TIG process. The material for the linkage is rectangular steel bar. The links were manufactured in the College of Applied Science machine shop and assembled with brass rivets. The hydraulic system was assembled and bled in the same machine shop. College facilities were used for fabrication.

Testing and Results

After fabrication, the prototype was tested for performance based on the design specifications. This proved that all of the design goals were met. The convertible wheelchair is easy to convert by one operator and produces a reclined position that reasonably replicates a typical examination table. Conversion is made simple by the use of a hand pump that both lifts and reclines the wheelchair into a position that approximates the general shape of an exam table found in most doctors’ offices. Test results are shown in Table 3. Ten health care professionals used the new wheelchair to evaluate the performance. The last four items in Table 3 were obtained from them. The product was rated subjectively for sturdiness, simplicity and ease of conversion. A rating scale of 1-3 was used with 3 being the best.

Specification	Goals	Result
Position of reclined chair (°)	<30	26
Height of reclined chair (in)	>22	24.5
Force of conversion (lb)	<10	0.5
Number of Health care Professionals Required for Conversion	1	1
Time of conversion (min)	<4	1
Product Satisfaction (1-3) (Sturdiness, Simplicity, Etc.)	2-3	2.6 (Average of 10 responses)

Table 3. Test Results

The following pictures (Fig3&4) show the two extreme positions of the wheelchair with a user in it. The wheelchair can also rest in any position along the motion path to provide the user with the added benefit of changes in sitting positions throughout the day. In addition, the height of the seat from the ground can range from 21 to 26 inches. Most health care professionals used a height of 24.5 in.



Figure 3 Prototype in Upright Position



Figure 4 Prototype in Reclined Position

Conclusions

The cooperation of the nursing home staff and the MET department resulted in the design and fabrication of a prototype of the Bi-Use Wheelchair/Examination Table. The prototype met all of the design specifications per the “Voice of the Customer”. The lifting and reclining motions are controlled by the same hydraulic system. It allows the patient to receive a proper examination in the correct position thereby reducing physical stress on all parties involved. All of these were accomplished without affecting the normal functionality of the wheelchair. By successfully completing this project the student satisfied the following learning objectives [5]:

- Synthesizing knowledge from earlier courses
- Going from concept to a working prototype
- Project Management
- Time Management
- Vendor Interaction
- Oral and written communication

In addition to creating a prototype these type of projects foster good relationship between the university and local community organizations.

Recommendations

After observing the prototype in operation, the following improvements are recommended:

1. Make the wheelchair collapsible for portability.
2. Relocate the brakes for easier access by the user.
3. Improve the lifting mechanism for smoother operation.

References

1. RESNA, <http://www.wheelchairstandards.pitt.edu/ANSIRES/SOWHATindex.html>.
2. Tilley, Alvin R., *The Measure of Man and Woman: Human Factors in Design*, Henry Dreyfull Associates, 1993.
3. Woodson, Wesley E., Barry Tillman, Peggy Tillman, *Human Factors Design Handbook*, McGraw Hill, 2nd edition, 1992.
4. Dieter, George E., *Engineering Design*, McGraw Hill, 2000.
5. International Senior Capstone Design Initiative, Boronkay, Thomas; Dave, Janak; Al-Ubaidi, Muthar, Proceeding of ASEE 2002 Annual Conference, Montreal Canada.

Thomas G. Boronkay, PhD, PE is a Professor in the Mechanical Engineering Technology department at the University of Cincinnati. He received his PhD from the University of Cincinnati. He has presented papers at ASEE Annual Conferences, ASME International Congress, and several international conferences and conducted CAD/CAM/CAE workshops nationally and internationally. He has also served in various capacities on the DEED, EDG and International Divisions' executive committees.

Janak Dave PhD, PE is a Professor in the Mechanical Engineering Technology department at the University of Cincinnati. He obtained his MS and PhD in Mechanical Engineering from the University of Missouri at Rolla. He has presented papers at ASEE Annual Conferences, ASME International Congress, and several International conferences and conducted CAD/CAM/CAE workshops nationally and internationally. He has held various positions in EDG and DEED divisions of ASEE, and local and national committees of ASME

Erika Shafts received her Bachelor of Science in Mechanical Engineering Technology from the University of Cincinnati in June 2002. She had been working at the Nursing Home throughout her college career. She continues to work there while finalizing her future plans.