

# **BIM as Design Exploration Tool in Architecture**

**Andrzej Zarzycki**  
**New Jersey Institute of Technology**

*Session 6 : Teaching project based courses and design courses, including senior design course.*

Recent developments in contemporary architecture have been significantly influenced by the emergence of digital technologies as a primary production tool allowing for new ways of thinking. These new developments, combined with research into new materials and fabrication technologies, make possible to pursue imaginative designs that were not possible in the past.

While often criticized for its overemphasis on formal expressions and its pursuit of the spectacular, digital creativity has matured and begun to take into account a multiplicity of design factors that define architecture. These factors relate to performance simulation and analysis, fabrication, and building information modeling (BIM). Consequently, new digital tools allow for broader reading of architecture, resulting in innovative designs and new expectations towards space and form.

Usually associated with the back end of the design process (implementation), building information modeling could also redefine the way design ideas are generated by bridging formal creativity with design and technological innovation. This is achieved through a close integration of generative tools with parametric capabilities and intelligent database-enriched digital objects.

Presently, BIM-based tools lack significant generative design modules and thus become peripheral within the architectural design process. This deficiency reflects the difficulty of reconciling the generative-lateral modes of creativity with the didactic-hierarchical modes of problem solving. At the same time, general-use, generative design software lacks the database dimension and material-based knowledge associated with its digital models. Often limited to simple mesh definitions, traditional digital models exist outside real units and dimensions, without any physical reference to the outside world. In this aspect, these digitally created designs still operate within the old paradigm, defined by Alberti [1], in which design is represented through a set of abstractions, analogies, and metaphors. They are digital in data definition, yet still analog in their conceptual framework. Architects may be able to develop interesting designs; however, it is impossible to verify whether these designs correspond to anything physically constructible, nor can they be associated with a particular scale or with particular material characteristics. This discontinuity in the creative process between generative and *implementive* design stages exemplifies a significant limitation of digital tools. To bridge this gap, this paper investigates generative qualities of the BIM platform through a relatively narrow but potent set of examples of parametrically controlled constructional details. It proposes extending BIM interoperability and parametric qualities into early, generative design phases, thus introducing two-directionality to a traditional process that follows a general-to-specific way of conceptualizing.

This paper discusses the integration of building science courses with the design studio, which offers lessons that can also be applied to everyday architectural professional practice. It proposes a design methodology that starts with a construction detail, and pursues designs that naturally emerge out of the assembly of discussed components. [2] While this is a long-practiced approach, this study broadens this method by considering a broader set of design solutions

resulting from parametric alterations and alternations of original components. The final design project emerges through a series of explorations with fragments informing the entirety of the architectural design solution: fragments that are representative of the overall design. It is conceptually and metaphorically analogous to a fractal relationship, where a component implies an overall structure.

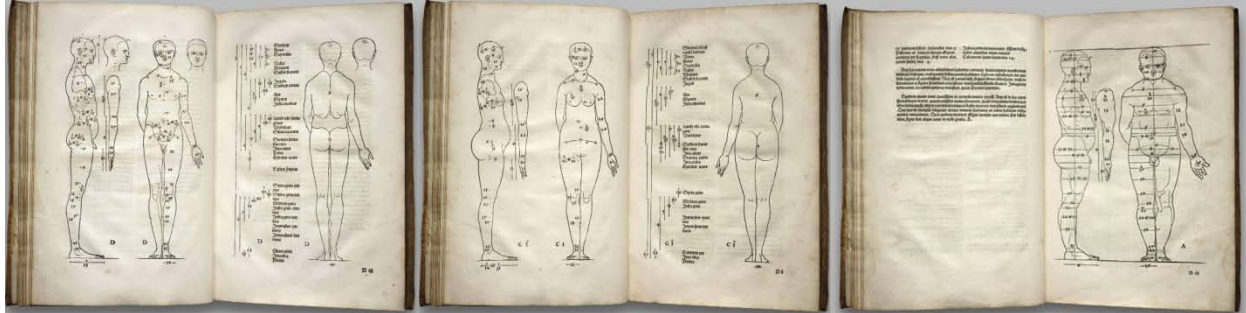

Figure 1 Albrecht Dürer's proportional studies of humans relate to (parameter-based) transformations of biological forms. [3]

This fractal-like quality manifests itself through a biological analogy, where an individual component or design is altered and reused within the same organism or in its next evolutionary version. Using this biological example, we can see that multiple versions of the same design, such as a leg or a skeleton, are parametric variations of the same original model. Studies by D'Arcy Thompson [4] immediately recall the phenotypical-visual transformability of distinct designs. When coupled with Dürer's proportional studies of humans [figure 1], they track an analogous conceptual trajectory of phenotypical developmental changes in an individual. While this progression is well demonstrated in evolutionary biology and explains the progression of species, an analogous conceptual framework is just beginning to be used in design and artistic practices. [5]

### **Drives for architectural ideas**

“In conceptual art,” according to Sol LeWitt, “the idea or concept is the most important aspect of the work. When an artist uses a conceptual form of art, it means that all of the planning and decisions are made beforehand and the execution is a perfunctory affair. The idea becomes a machine that makes the art.” [6] Conceptual art, as defined by LeWitt, closely resembles contemporary modes of architectural practice, both digital and analog. In these modes of practice, the focus on the underlying concept often overrides all other considerations. Consequently, the design process becomes a linear implementation tool rather than an exploratory and idea-finding environment.

Conceptual art follows a didactic and hierarchical process based on design concept or idea, as opposed to an explorative and intuitive idea-building approach. The design approach inspired by conceptual art establishes the central idea as the ultimate criterion for design validation and values consistency with concept subordination over open-ended explorations with accidental discoveries.

The detail-based design approach for architecture, discussed in this paper, stands in contrast to past concept-centered design process as well as recent trends in which the weight of conceptual thinking, either in architecture or in the visual (fine) arts, has often taken precedence over tactile or material considerations. This has been evident both with traditional (analog) and

with digital-based creativity. However, recent developments in fabrication, particularly in conjunction with the parametric BIM platform, create opportunities for balancing this emphasis on conceptual thinking by bringing material and assembly considerations to the forefront of architectural discourse. Architecture returns to realm of making, rather than conceptualizing. Traditional or digital form making not only considers structural behaviors of particular geometries, as was the case with Antonio Gaudi's or Frei Otto's works [7], but also starts considering material properties that could only be partially accounted for in Otto's soap-bubble models. Computational environments not only allow for readdressing materiality that is often missing from the design process, but also allow for asking speculative "What if..." questions. Material properties can be parametrically investigated in similar ways to tectonics or building performance characteristics such as lighting or thermal behavior.

### **Educational Design Model**

The educational approach discussed in this paper—evolving design through the assembly of parametric components—is a special case of a broader consideration of material characteristics, as well as methodologies and tools, in the production of design. Developing parametric construction details, either in digital or in physical and fabricated forms, and subsequently using them as design drivers for architectural form is consistent with Kahn's postulate--"What do you want, brick?"--and represents thinking that is efficient, reliable, and an effective way to design. This paper looks at a number of contemporary designs that follow similar conceptual logic. It points to a possible class of designs that are conducive to the discussed approach. In a teaching context, these examples became design references and helped students to apply this approach in their own studio work.

To connect generative creativity with professional practice and building technology education, the course uses BIM software. Presently, it is the only single platform that can successfully address constructability and design integration issues. However, working with BIM software has proven difficult for many designers because of the narrow range of designs that are possible with the applications. To overcome BIM's limitations as generative software, the course approach was to focus on selected software capabilities that allow for unencumbered creativity in the context of suitable design language. Thus, defining appropriate architectural precedence, in the form of case studies, was critical.



Figure 3 Waterloo Station by Nicholas Grimshaw could be used to study parametric variations of a truss system.

For appropriate precedence, we investigated contemporary designs representing high quality practices, which naturally translated into parametric and BIM platforms. Projects by Nicholas Grimshaw, Norman Foster, and Santiago Calatrava [fig.2] were just a few of the designs that fit well into the class methodology and were relatively easy to handle using digital tools. In selecting projects and particular assembly components or construction details, students were

asked to study these precedences, model partial assemblies, and test them as a three-dimensional BIM models.

This assignment had two distinct purposes and phases. The first portion of the assignment—knowledge building—focused on research and modeling of an architecturally significant precedence. It lets students get familiar with construction detail, assembly, and the interface between architectural and structural systems. The second portion—design formation—used the intrinsic ability of a parametric object (detail) to explore design scenarios that allowed for new design concept formation by transcending precedence into qualitatively new designs. When choosing examples for their explorations, students were asked to consider the open-endedness of their particular designs and their ability to develop meaningful variations.

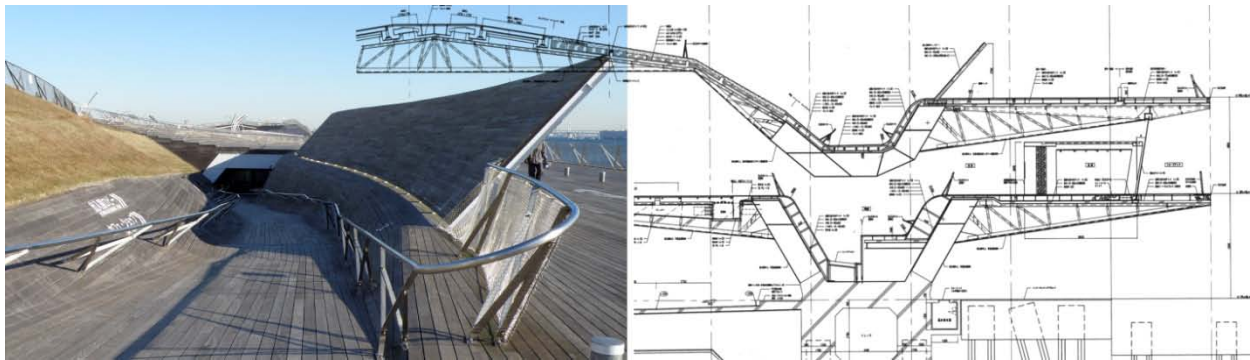

Figure 3 Digital construction detail as an opportunity to research existing architectural precedence, Yokohama Terminal, FOA.

In this phase of the assignment, students learned about the spatial coordination of various elements and system components, their interconnectivity, and their interdependencies [fig.3]. Students were able to manipulate and experiment with parametric components and to follow interactively through the design alteration. Later, in the second part of the project, students explored the parametric possibilities of BIM models [fig.4]. Three-dimensional, parametrically resolved architectural details served as speculative, idea-generating devices for design. Students were expected to demonstrate the creative possibilities of their BIM models and to document their parametric explorations [fig.5] through images, digital models, and a text narrative (final report).

YOKOHAMA TERMINAL  
FUSION OFFICE ARCHITECTS



Figure 4 Parametric variations of the roof/deck structure, Yokohama Terminal, BIM model.

The aim of this exercise was to help students to develop technical knowledge necessary for the pre-comprehensive and comprehensive studios. Specifically, it addressed the integration of building systems and their appropriateness to the design intent. Additionally, this assignment



facilitated material, dimensional, and construction detail investigations in the context of contemporary architectural practice. The level of the applied constructional knowledge for this assignment matched that of the comprehensive studio work and of professional architectural practice.

With parametric analysis, students can immediately trace design changes and see how they impact other components in the assembly [fig.5]. Combining or nesting parametric components not only allows for an ease of modeling and a greater flexibility, but also allows understanding of how individual changes impact an overall design. Once a single parameter was changed in an overall, often complex, assembly of individual components, students were able to trace the propagation of changes throughout the database model and immediately evaluate the consequences of this particular change. Also, they could propose new designs through interactive manipulations of parameters and see changes propagated through the entire system assembly. This dual use of parametric digital models—for understanding of a significant architectural precedence (construction knowledge building) and for speculative explorations of possible design propositions—allows for greater integration between building science courses and the design studio. This is particularly applicable in the upper-level comprehensive studios where generative and implementive aspects of design need to be reconciled. In parametrically defined BIM environments, students can explore designs that are native to the world of construction—that do not have to be translated or reinvented as a result of the progression from a conceptual idea to a real product [figs 6, 7,8].

However, to be effective, this method has to approach design from a perspective characterized by inductive thinking, from particular to global, from the precedence to a qualitatively new design.

This reposition from didactic to inductive ways of thinking puts greater focus on design explorations and lesser focus on the hierarchical design process.



Figure 5 Analyzing parametrically-driven behaviors of element assemblies. A fully detailed beam at the slab condition with parametric control of the beam's depth and slab thickness. Remaining geometries follows spatial transformations of the beam and slab.(Alex Merlucci, NJIT)

Construction knowledge taught in architecture schools is often either irrelevant—discussing old, simplified architectural examples not related to students' current studio work—or else highly complex, representing contemporary design trends such as blobs and warps. In the latter case, it is often beyond students' ability to comprehend the information presented and apply it in their studio projects. Consequently, a certain built-in incomparability leaves students confused and less prepared for the professional life.

At the same time, the integration of building technology within upper design studios is critical. As a result of new digital tools and developments in professional practices, students increasingly

develop designs that exceed their technological knowledge. This has the potential to further fragment expertise and weaken design practice by driving it toward paper-based architecture. It also has immediate implications for the education process and specifically for changes in technology teaching methods.

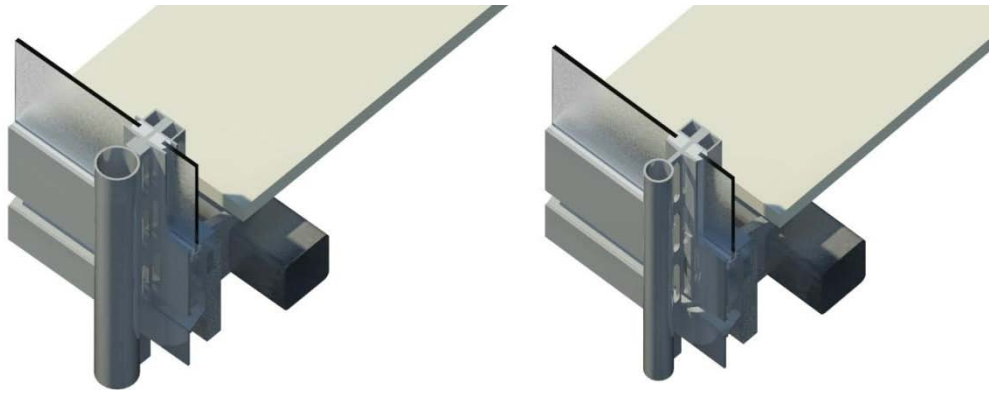

Figure 6 Parametric detail manipulations,

A common argument for BIM, and for digital design in general, is that it allows for early decision making. Thus, BIM facilitates effective design progression from the conceptual to more concrete development and implementation stages. The other argument that is often put forward is that BIM allows for deferral of design decisions exactly because of its parametric properties.

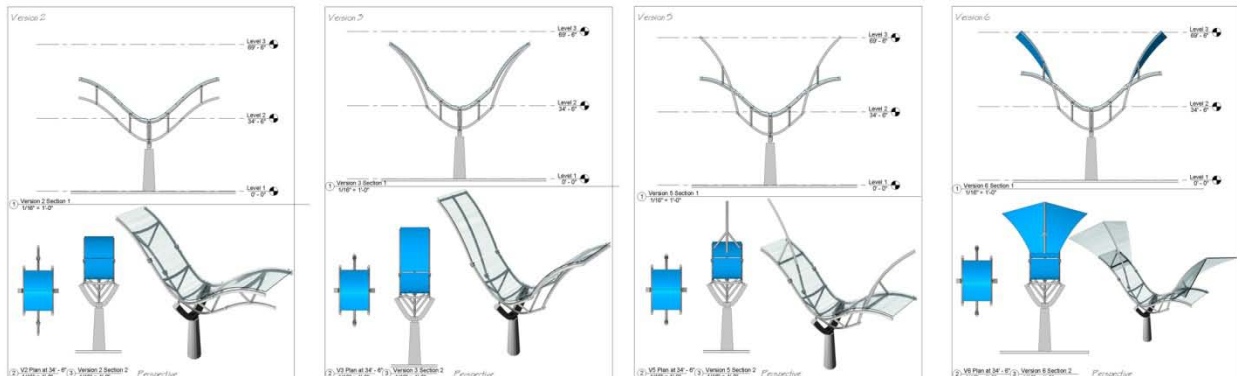

Figure 7 Parametric details allow for alternative design explorations and creating larger assemblies

While both arguments are reasonable in their particular rationales, they also seem to exemplify both blessings and impediments to the design process. Depending on circumstances, early decision making may limit the procrastination and idle versioning common in architectural production, where a lack of direction or infinitesimal small variations in design alternatives effectively loop a designer into a closed design circle. Early decision making allows an experienced designer to validate his or her scenarios by introducing the constructability component into design.

At the same time, it is evident that the parametric capabilities of digital models allow for deferring specific design decisions while still considering a parametric component as an interdependent element of an overall system. In this application, parametric objects serve as intelligent placeholders for design. These placeholders can be changed if necessary, but,

independent of the accuracy of their numeric values, they still function effectively as active elements of a larger interdependent system.

This property of parametric objects becomes a critical characteristic of BIM construction models, not only in understanding the models' assembly but also in applying them as explorative and generative tools for architectural design. This dual ability of BIM models—allowing designers to introduce constructional considerations in the early design stages, and later, due to the components' parametric definition, to develop variations and generate alternatives at the very end of the design process—reunites the act of conceptualizing with the act of making. It also renegotiates the boundary between design generation and design implementation. This renegotiated boundary will impact architectural practice and design team dynamics by increasing the requirement for each team member to contribute equally to the design and constructability of the project. Since design and implementation in BIM become more tightly intertwined, the separation into designer and detailers becomes meaningless. The next level of the design production integration removes architectural drafters from a design team structure.



Figure 8 Final design implements multiple parametrically altered instances of the same proto-element, Sophia Sobers, NJIT.

## Final Thoughts

This paper discusses an adoption of BIM tools as a teaching opportunity for various aspects of the architectural curriculum, from building technology to the design studio. It specifically focuses on BIM-based parametric modeling in discussing construction details, assemblies, and design explorations in the design studio context.

The introduction of parametric thinking into building systems courses not only allows for understanding the interdependencies between various elements of a building assembly, but also opens doors for “What if...?” speculative exploration. This second aspect of parametric thinking encourages students to bridge technical knowledge with creativity.

This paper discusses where BIM software should be, not necessarily what it already does. It highlights BIM potentialities, not today's level of software or designers' ability to use it effectively. However, the above statements are based on the various design and educational projects that take advantage of various fragmentary software capabilities that are already present or possible in today's practice. They use these fragmentary capabilities to set a path and expectations toward future BIM practice.

While it is often convenient to discuss what a particular software application, tool, or methodology can or cannot accomplish, an equal burden should be placed on a user and his or her creative ability to apply these tools. The shift in tool development advocated in this paper is necessary, but an even more substantial change needs to occur in the way designers operate and conceptualize with these tools. This responsibility for growing up to match the capabilities of the tools we use is a much harder task, one that should be better handled both in professional practice and in academia. This paper naturally evolved as a response to research, teaching, and architectural practice pursuing design creativity in the context of digital, and specifically BIM, tools.

## Bio

Andrzej Zarzycki is a designer and educator who employs digital tools to create experiential architectural spaces. Andrzej brings over 15 years of professional practice combined with design and technology teaching into the New Jersey Institute of Technology (NJIT). His research focuses on media based environments as well as validation methodologies of generative designs through building performance analysis and simulation tools. Andrzej Zarzycki earned his M.Arch from the Technical University of Gdansk, Poland, and S.M.Arch.S from Massachusetts Institute of Technology, Cambridge, MA. Contact: [andrzej.zarzycki@njit.edu](mailto:andrzej.zarzycki@njit.edu)

## Bibliography

Ford, Ed; *The Details of Modern Architecture*; Cambridge: MIT Press; 2003  
Guidera, S., 2006, *BIM Applications in Design Studio: An Integrative Approach to Developing Student Skills with Computer Modeling*, in “Synthetic Landscapes” : The ACADIA 2006  
Leatherbarrow, David; “Architecture’s Unscripted Performance”; *Performative Architecture – Beyond Instrumentality*; NY: Spon Press; 2005.  
Penttila, Hannu; Dong, A, Vande Moere, A & JS Gero (eds), *Early Architectural Design and BIM, CAADFutures’07*, 291-302. Springer.

## References

- 
1. Alberti, Leon Battista; *On the Art of Buildings in Ten Books*; 1991
  2. Wallick, Karl and Zaretsky , Michael, *Fragmentation and Interrogation as an Approach to Integration*; ACSA Proceedings, Value of Design, Annual Conference March 2009
  3. - Dürer, Albrecht; *De Symmetria. . . and Underweysung der Messung*; Nuremberg 1538
  4. Thompson, D’Arcy; *On Growth and Form*; 1992
  5. Ambrose, Michael A. 2006. *Plan is Dead: to BIM or not to BIM, that is the question. Computing in Architecture / Re-Thinking the Discourse: ASCAAD 2006*  
Ambrose, Michael ; *Agent Provocateur — BIM and the Design Studio: Questioning Roles of Abstraction and Simulation in Design Education ACSA 2009 Annual Conference: The Value of Design*; p.85
  6. LeWitt, Sol “Paragraphs on Conceptual Art,” *Artforum*, June 1967.
  7. Otto, Frei, Rasch, Bodo; *Finding Form; towards an architecture of the minimal*; Edition Axel Menges, 2001