

Board 101: Rebounding Energy

Prof. Bala Maheswaran, Northeastern University

Bala Maheswaran, PhD Northeastern University 367 Snell Engineering Center Boston, MA 02115

Rosalyn Bell Beckwith

Montserrat Velasco

Emily Minkler

Eleanor Altwarg, Northeastern University

Rebounding Energy: Harnessing Vibrational Energy from Basketball Using Piezoelectric Generators

Rosalyn Beckwith, Montse Velasco, Emily Minkler, Eleanor Altwarg, Connor Albright,
and Bala Maheswaran
College of Engineering
Northeastern University

Abstract

It is well known that some energy always is dispersed to the surroundings in the form of heat, mechanical energy, sound, and many other ways. Our team was brought together in Cornerstone of Engineering 1 and 2, an accelerated introduction to engineering course at our university, by the inspiration to conserve energy using these concepts. The team, students pursuing degrees in chemical, mechanical, and electrical engineering, aimed to design a device that would utilize the energy generated from everyday practices that are otherwise wasted. We focused on conserving energy in the game of basketball, a high-energy and globally popular sport. The goal was to design and build a device that harnesses the vibrational energy generated when a basketball is hit against the backboard of the basket, while not interfering with the game or being of high maintenance to the users. To transfer the kinetic energy from the vibrations of the backboard to electrical energy, a series of piezoelectric vibrational crystals were placed on a panel attached to the backboard. The size of attachment was sized down (approximately half size) to be tested on a smaller backboard. Using piezoelectricity was determined to be the most fitting for our project goals while being available at a relatively low cost. Furthermore, the product was designed as a portable attachment so it was user-friendly and more practical. The developed solution to the problem stated worked well and could be considered for use in the future of basketball for energy conservation.

Introduction

The concept of harnessing vibrational energy from a basketball is to using the energy produced by the ball's vibrations to power devices or generate electricity. This idea is based on the fact that when a basketball is bounced or hit, it creates mechanical vibrations that could potentially be converted into electrical energy. There have been some experimental studies exploring the use of piezoelectric materials to capture the vibrational energy from a basketball and convert it into usable electrical energy. Piezoelectric materials produce a voltage when subjected to mechanical stress, which can then be harnessed to generate electricity. While the concept of harnessing vibrational energy from a basketball is interesting, it is not practical for widespread use at this time. Further research and development is needed to make this a viable solution for energy generation.

Although researchers have hypothesized about taking advantage of vibrational energy for the production of power [1]-[5], Vibration Energy Harvesting was only developed relatively recently. This concept became more concrete in the 2000s with the growth of MEMS (Micro-Electro-Mechanical System) devices in the medical field, which are microscopic devices that use mechanical and electrical components [6]. In the past couple of decades, this technology has evolved to generate electromagnetic, electrostatic, and piezoelectric devices as well. In 2007, researchers at the Georgia Institute of Technology developed environmentally powered nanogenerators to monitor blood flow [7]. The same year, the University of Southampton made

advances in magnet-based generators that could be placed on bridges to capture mechanical energy from vibrations [8]. PaveGen then took a different approach when it created paving slabs in order to gather energy from people's footsteps [9]. Moreover, in 2013, ReVibe Energy was founded and maximized this technology in larger-scale industries such as mining, construction, and railways, through a self-power monitoring system [10]. These developments portray the variety of appliances that Vibration Energy Harvesting has.

Method and Approach

After deciding to harness energy from a basketball backboard, the decision to use piezoelectric generators, otherwise known as buzzers, was made shortly after. There were multiple ideas for how to attach the generators to the board as well as where to place them. The original paper prototype contained three panels of four buzzers each (Figure 1). However, after research into the sizes and ability of the buzzers, the decision was made to construct fewer sensors per panel and to tailor the number of panels required to the specific system. Scoreboards that required a higher input of energy would simply need to obtain more panels to work. The portability factor of the design was a priority throughout the project. This was reflected in the paper prototype by the use of Velcro dots to attach the cardboard panels to the backboard and proved to be effective in securing the buzzers to the board.

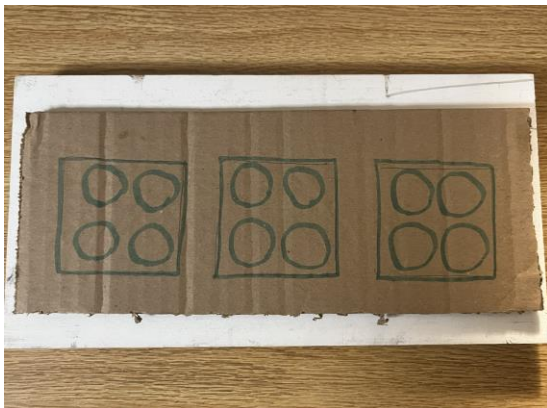

Figure 1. Scaled Paper Prototype

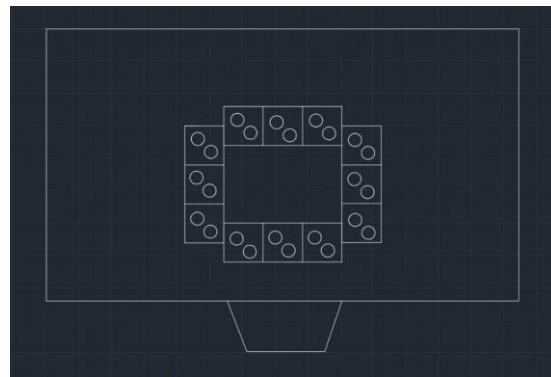

Figure 2. 2D AutoCAD Model

In the CAD designs, the panels (each consisting of six buzzers) were attached around the rim of the inner square, as demonstrated in Figure 2. Originally, the idea was to arrange the buzzers in a series pattern and in this domino format. This concept continued into the 3D design stage, which is shown in Figure 3. After experimentation, it was decided to use a parallel circuit for the buzzers but keep the four panels inside the square. The majority of the shots in a game hit the inside square, causing it to be the optimal area for placing the sensors to collect the maximum amount of volts.

Both the 2D model displayed above as well as the 3D model below show the rear view of the backboard where the panels are attached. The models are also scaled to half the dimensions of an official basketball backboard, which was a more realistic model to compare to the final product design. The Solidworks Model is pictured as an assembly, with all the panels attached as one piece or as a single Solidworks part.

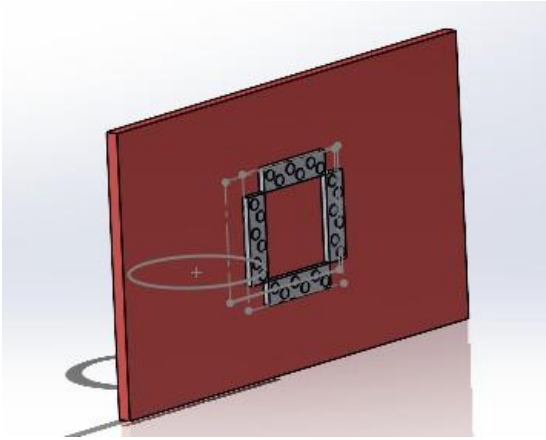

Figure 3. Backside View of 3D Solidworks Model

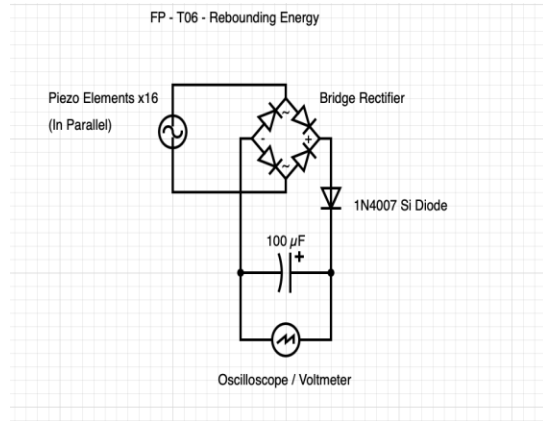

Figure 4. Circuit Diagram for the backboard

Design Details



Figure 5a. Final design backside view



Figure 5b: Final design front view

When the piezo elements are compressed by the wall and the backboard, this causes the piezoelectric effect to take place as the material is crushed causing an AC signal to be generated. The circuit diagram, displayed above in Figure 4, serves as a visual representation for the electrical components in the following explanation. Using the piezoelectric elements in parallel with one another favors a higher current output when compared to placing these sensors in series, which

ultimately gives a higher power output as well. This is inferred from using the Ohm's Law formula for power, $P = VI$ where voltage and current are proportional in the relationship for power. Even though a higher voltage could be achieved from placing the elements in series, this preference towards current ensures that the signal will be strong enough to apply energy to things such as LEDs. This AC signal that has been generated then goes through bridge rectification essentially flipping the negative signal inversely to give a pure DC signal [11], as well as increasing the overall output from the combination of the inverted negative voltage with the positive voltage. The DC signal is then sent to a smoothing capacitor, shown in Figure 4 to be $100\mu F$, where the charge is held inside the capacitor, acting as a battery. This capacitor then can be discharged to be used for other purposes such as charge for the scoreboard LEDs or other related matters.

Figures 5a. and 5b. displays the prototype for the product. Figure 5a shows the materials for the project including the electronic and 3D printed components. The green strips were designed and 3D printed to support the piezoelectric buzzers that were placed on the cardboard panel. The panel was chosen due to its low cost to remain within the economic constraints of the project guidelines. Ideally this panel would be replaced with a carbon fiber substitute. The oscilloscope connected to the board on the left of Figure 5a measured the output voltage. Figure 5a. highlights the project's compactness and nonexistent impact on the game itself. As shown, the attachment has no components that would obstruct the gameplay in any way as the part is attached only to the back of the board. This prototype produced insightful reference data that is analyzed in the results and discussion session below.

Results and Discussion

In order to collect data, a scaled basketball was thrown on the backboard from approximately 4.5 ft. away. The data was collected using a digital multimeter in parallel with the capacitor in order to measure the voltage that was stored from the use of the backboard. The testing conditions set were taking shots as you would in play rather than throwing the ball with force to ensure no extremes were measured. For our initial measurements, an average of 2.056 volts was measured for every five impacts of the basketball on the backboard since each trial consisted of five shots. This means that the average Voltage per single shot was 0.411 volts. The individual data of the shots is shown in Table 1.

Trial #	1	2	3	4	5
Capacitor Voltage (V)	1.81	2.46	2.16	1.97	1.88

Table 1: Results from Trials

The original project goal was to power a scoreboard for the average duration of a basketball game [12]-[14]. To quantify this goal, we calculated that the average game to be about 2 hours, and a scoreboard contains four numbers that contain 13 LEDs each, making 52 LEDs. Therefore, to meet our goal, our product must generate enough energy to power 52 LEDs for 2 hours straight. For our data as well as the rest of the conclusion, the focus of the research was on the powering of the LEDs as well as storing the energy generated. Storing the energy rather than instantly using it to power a scoreboard would be useful during practices and warm-ups when a lot of energy could be generated yet a scoreboard is not needed. As previously discussed, from experimentation, five shots resulted in about 2 volts of electricity. According to Kithub, it often takes 2-3 volts to power one LED. After some preliminary research watching NBA games, there are approximately 160 shots (including both hoops) in a game of basketball. This means that there would be

approximately 64 volts of electricity generated per game. The 64 volts generated could power about 32 LEDs, assuming 2 volts per LED. It can be concluded that in order to achieve our goal, about one and a half games would have to be played (52 LEDs powered/ 32 LEDs powered per game) instead of one game.

From the measured number of volts generated per shot, the amount of voltage that one panel could generate was calculated to be 0.5 V. By adding three more panels and generating about 1.5 more volts of electricity, our goal of powering the scoreboard in a single game would be achieved. These calculations are shown below in Figure 6. While this solution would have improved our product and enabled us to meet our original design goals, it required us to order additional buzzers, which due to time constraints was not possible.

$$\frac{160 \text{ shots}}{1 \text{ game}} \times \frac{3.5 \text{ volts}}{5 \text{ shots}} \times \frac{1 \text{ LED}}{2 \text{ volts}} = 56 \text{ LEDs powered per game}$$

Figure 6. Dimensional Analysis for Results

Learning Outcomes

Cornerstone of Engineering is an advanced 8 credit hour course designed for all engineering majors and covers fundamental engineering concepts. The course covered technical skills, such as C++, MATLAB, Solidworks, and AutoCAD, hands-on skills, such as laser cutting and prototyping, and soft skills such as communication and creative thinking. Alongside these learning activities, the course consisted of a semester long project to implement these skills, which led to the development of Rebounding Energy: the piezoelectric backboard attachment.

The beginning of the course started by learning how to design a product while considering factors such as cost, timelines, practicality, user friendliness, environmental impact, and inclusivity. While conducting original research into the project, the team developed an appreciation for energy saving inventions due to the difficulty of the intersections of costs, time, and product quality. Making the device high in efficiency yet affordable and sustainable was challenging. For better results, materials that are more expensive would need to be purchased, which did not align with our constraints. This was overcome by using lower quality materials, such as cardboard, electronics, and 3D printed parts, that were either created by the team or obtained through our university's First Year Engineering Learning and Innovation Center (FYELC). Planning how to use the resources we had was an engineering challenge the team learned from.

The team also implemented technical skills and effective communication learned throughout the course. The project required CAD models during the design process, as shown in Figures 3 and 4. This allowed the students to apply these skills to a relevant problem which sparked motivation and interest in the software. Multiple presentations were given at different milestones of the project. The entire team began the term explaining the concepts and projected budget of the product and concluded with showing the results and relevant data to a captured audience.

While the goals associated with the project revolved around the engineering design process, the team also learned about electricity, electronics, and energy conservation among other topics. Most of the team did not have strong backgrounds in electrical engineering and energy conservation

going into the project, so much time was spent learning about the core knowledge behind the project. After focusing and learning about how to generate and store energy, the team decided on piezoelectric technology. Most of the team had not been exposed educationally to piezoelectricity, which made the project a new and exciting experience. This knowledge has helped the team in classes outside the project and aided in making connections with real life systems as well.

The team also developed skills when prototyping, redesigning, and manufacturing the product. Developing the prototype gave the team clarity into the priorities of the project and the problems to overcome. After obtaining a more physical understanding of the product, the team reconvened and decided to lower the number of buzzers on each individual panel to create a more compact design. The development of the product was also an important learning experience as the team learned how to integrate code, electronics, and mechanical components to store energy and obtain data.

The student team members initiated the project from concept to design to implementation to communicating the results of the product. Our professor, who led Cornerstone of Engineering, mentored the team and provided support throughout the project. After each milestone presentation feedback and instruction was given to guide the team. While the work of the project was split evenly between the students, certain members took more responsibility for certain areas of the project, such as the CAD, electronics, assembly, testing, data analysis, and presentations. Collaboration was emphasized in the class to ensure everyone was on the same page within the project and to gain practice working with a team. Due to the effective communication of the group, the entire team was involved in every step of the project.

Conclusion

The product developed and tested highlighted the design's potential for becoming an accessible and reliable energy-saving device. From the concept design to the final product, creating a product that was low-cost, low-maintenance, and easily implemented was a priority. These factors contribute heavily to making a product that anyone could obtain and maintain, which was an important goal for the team. This decision influenced the project in many ways. For example, using piezoelectric energy was chosen because it provided the amount of energy required for a generally low cost of the sensors. In addition, the sport of basketball was selected due to its popularity and widespread nature. The portable aspect of the product allowed for the attachment to be implemented into already existing hoops, which allowed the team to avoid creating a new system, cutting costs significantly. This aspect was conveyed by the CAD models as well as the paper prototype and final product design, showcasing the Velcro used on the hoop as the attachment method for the panels.

The research conducted was successful in implementing the concept of the original design with minor modifications. The proof of concept was shown in the resulting data of an average of 0.411 V per shot recorded. In addition, when scaled to the correct number of attachment panels, the product would generate enough electricity to power a scoreboard for an entire game. Taking into account the scale of the attachment and basketball as well as the number of shots that hit the backboard during a game, the potential for saving energy is apparent. However, considering the legal hoops and paperwork involved in implementing a new device during official basketball games, it was decided that the design would be most effective during basketball practices or warmups as the

amount of energy generated is largely dependent on the number of impacts the board experiences. This would also eliminate any concern about the product interfering with official gameplay. This project was successful in proving the design concept and gaining a good understanding of the specifics of the product design. With minor improvements, the Rebounding Energy backboard attachment could be implemented anywhere to conserve a combined substantial amount of energy globally.

References

- [1] J. E. Company, "The piezoelectric effect - Piezoelectric Motors & Motion Systems," *Nanomotion*, 28-Aug-2018. [Online]. Available: [https://www.nanomotion.com/nanomotion-technology/piezoelectric-effect/#:~:text=Regarding%20piezoelectric%20motors%2C%20the%20piezoelectric,\(such%20as%20ceramic%20strips\)](https://www.nanomotion.com/nanomotion-technology/piezoelectric-effect/#:~:text=Regarding%20piezoelectric%20motors%2C%20the%20piezoelectric,(such%20as%20ceramic%20strips).). [Accessed: 04-Dec-2022].
- [2] F. Orfei, "Introduction to vibration energy harvesting - technical articles," *All About Circuits*, 19-Aug-2019. [Online]. Available: <https://www.allaboutcircuits.com/technical-articles/introduction-to-vibration-energy-harvesting/>. [Accessed: 04-Dec-2022].
- [3] "Industrial Monitoring Systems: Self-powered IOT systems from Revibe," *Revibe Energy*, 22-Nov-2022. [Online]. Available: <https://revibeenergy.com/>. [Accessed: 06-Dec-2022].
- [4] "Producing energy from vibrations," *AltEnergyMag*, 16-Jul-2020. [Online]. Available: <https://www.altenergymag.com/article/2020/07/producing-energy-from-vibrations/33439/>. [Accessed: 04-Dec-2022].
- [5] Q. Zhao, Y. Liu, L. Wang, H. Yang, and D. Cao, "Design method for piezoelectric cantilever beam structure under low frequency condition," *International Journal of Pavement Research and Technology*, vol. 11, no. 2, pp. 153–159, 2018.
- [6] J. Iannacci, *RF-MEMS Technology for High-Performance Passives The challenge of 5G mobile applications*, Nov. 2017.
- [7] D. Murph, "Georgia Tech researchers develop environmentally-powered nanogenerators," *Engadget*, 13-May-2021. [Online]. Available: <https://www.engadget.com/2007-04-11-georgia-tech-researchers-develop-environmentally-powered-nanogen.html>. [Accessed: 04-Dec-2022].
- [8] P. Glynn-Jones, M. J. Tudor, S. P. Beeby, and N. M. White, "An electromagnetic, vibration-powered generator for Intelligent Sensor Systems," *Sensors and Actuators A: Physical*, vol. 110, no. 1-3, pp. 344–349, 2004.
- [9] "Every step generates a powerful connection," *Pavegen*. [Online]. Available: <https://www.pavegen.com/>. [Accessed: 04-Dec-2022].
- [10] "KR20110011085U - electricity production basketball backboard," *Google Patents*. [Online]. Available: <https://patents.google.com/patent/KR20110011085U/en>. [Accessed: 04-Dec-2022].
- [11] Michal, D. wijesinghe, A. pund, F. Öhrnberg, Stephen, and R. pandey, "Full wave bridge rectifier with capacitor filter design calculation and formula," *Electric Shocks*, 04-Jul-2022. [Online]. Available: <https://electric-shocks.com/full-wave-bridge-rectifier-operation-with-capacitor-filter/>. [Accessed: 04-Dec-2022].
- [12] S. Boisseau, G. Despesse, and B. Ahmed, "Electrostatic conversion for vibration energy harvesting," *Small-Scale Energy Harvesting*, 2012.
- [13] R. Wilkins, "How many volts are needed to power an LED?," *KitHub*, 08-Feb-2019. [Online]. Available: <https://kithub.cc/2015/11/how-many-volts-are-needed-to-power-an-led-2/#:~:text=One%20question%20that%20people%20who,Electrical%20Engineer%20grad%2C%20Luz%20Rivas>. [Accessed: 06-Dec-2022].
- [14] "US4111420A - energy absorbing basketball goal/backboard unit," *Google Patents*. [Online]. Available: <https://patents.google.com/patent/US4111420>. [Accessed: 04-Dec-2022]. [Online].