

# **Capstone Mechanical Engineering Design Experience - An Industry Based Partnership**

**Ismail I. Orabi, Ph.D.**

**Professor of Mechanical Engineering  
Tagliatela College of Engineering  
University of New Haven  
West Haven, CT 06516**

## **Abstract**

The objective of this paper is to present our findings and experiences in how to use industrial projects successfully, especially in terms of guidelines for selecting projects and managing them throughout the course. This paper will convey the impact of the changes to student learning and overall experience of the faculty involved using industry projects.

The goal was to significantly elevate the quality of project work undertaken, and this was accomplished by having teams of three or four students working under real world constraints of time and budget, to produce a product or process that meet client's specifications. The first step in this process was to secure several projects from industry together with a commitment from a practicing engineer to serve as project liaison (the client). At the end of the semester, the college will hold a senior- project symposium in which each student team will present the results of its work to their clients and other invited to participate in the evaluation process.

This paper will discuss the development of industry-sponsored projects into a mechanical engineering capstone design courses. Examples of the current projects will be presented.

## **Introduction**

Senior design engineering courses have increasingly used industry-sponsored projects that give students opportunities to address real world problems [1-4]. Capstone design courses are also a site for developing many of the higher-level engineering learning outcomes and those requiring integration of innovation, problem solving and knowledge. The vast majority of capstone design instructors assign great value to the capstone design course [5-6]. Many believe their courses offer potential for achieving and assessing all of the engineering criterion 3 outcomes required by ABET [7].

The mechanical engineering capstone design instructor has initiated the industry- sponsored program for the 2008-2009 student projects. The mechanical engineering capstone design course is intended to be a unique experience for senior engineering students. Students are required to complete a two- semester capstone design course sequence involving the application of their theoretical knowledge to solve pressing real-world problems. Each project includes the

development and use of design methodology, formulation of design problem statements and specifications, consideration of alternative solutions, feasibility considerations and detailed system descriptions. Projects include realistic constraints, such as economic factors, safety, reliability, maintenance, aesthetics, ethics, political and social impact. Students are expected to present orally their results in a series of design reviews. The students document their solutions using a written report that includes an executive summary. A working prototype or simulation of their solution, as appropriate, is required to complete the course.

**The following Senior Capstone Projects are supported by local industry for 2008/09:**

- Design a device capable of testing new air bearing design - sponsored by ASML
- Design an elevator safety braking device – sponsored by Otis, UTC
- Design a dicorrhinic model that simulates normal human breathing – sponsored by Z-Medica
- Design a portable bench top demonstrator to simulate ground resonance instability and enable real-time adjustments of the fuselage dampers – sponsored by Sikorsky Aircraft

**Course Objectives**

The students are expected to learn and demonstrate the abilities to:

- solve open-ended problems
- use design methodologies and technical analysis to implement solutions
- effectively communicate ideas in a written and oral format
- effectively work in a team
- integrate ethical, social, safety, cost and environmental concerns in the design process

**Topics covered**

The course involved four main components: (1) lectures by engineering faculty aimed at providing the students with important information on topics related to professional practice, (2) presentations by invited outside speakers, (3) administrative information related to design projects, and (4) a forum for the students' presentations of their design projects. The faculty lectures covered three main areas: structural analysis techniques, project management and design for manufacturability.

Another aspect of the course involved bringing in outside speakers to give seminars. Several of the speakers were practicing engineers from industry. Topics covered by the guests included Project Management, design for manufacturability, and a Intellectual property.” The challenge in presenting some of the research talks was keeping them at a level that undergraduate students can comprehend. One seminar was a joint effort with the local ASME section and hosted by a distinguished ASME speaker. If possible, speakers presented on one of the topics mentioned above as it related to their profession.

Early in the academic year, the course was devoted to providing students with important information needed on the design project. Issues such as expectations, resource availability, and

safety guidelines were discussed. Several oral progress reports were also given by members of each team. The students considered this course a culmination of their undergraduate experience. It prepared them for professional life by exposing them to contemporary issues in the engineering field. They learned about a range of engineering research projects and about engineering challenges including fund allocation, time management, and teamwork. Students commented that this course gave them a sense of the engineering profession they were being prepared to enter and provided an excellent forum for increasing student faculty intellectual interactions.

The larger context (technical, social, economic, legal) in which the system might someday operate are included in the design process. Students are required to think about who will use this system, how, what other systems (power, support, maintenance) might be required. Students provide an analysis of ethical components of the system. They discuss the potential ethical issues, risks, safety associated with the design. Students prepare a set of recommendations for addressing possible ethical concerns. What could be done to avoid or alleviate them? These might include design changes, guidelines for proper use, documentation, the development of maintenance or training programs, etc.

### **Industry Partner Program**

The goal of the industry-sponsored program is to create a new paradigm for engineering education in which the theory and the practice of engineering are intricately woven together throughout all of capstone design courses in which students, professors, and practicing professionals work together to produce engineering graduates who truly are "Industry Ready" when they graduate.

The sponsor is expected to attend a project kick-off meeting of all industry sponsors and eligible students during the first week of the semester, at which time a brief presentation is given to the students to market the project. The industrial sponsors provide support to the project in the form of both financial and manpower commitment.

By the end of the second semester, a successful team will have carried a design problem through the various stages of a project life cycle including problem definition, data collection, model building, analysis of alternatives, project decision-making, preparation of recommendations, and delivery of results in oral and written form. The faculty meets with the team on a regular basis, typically at least once per week. The students have regular meetings in person or by telecommunication with the project sponsor or client. At the end of the semester, the faculty advisor and sponsors/clients are asked for their comments on each student's participation in the group meetings and overall contributions to the design process.

A donation of \$2,500 is requested for a project team from each company. Because this is a tax-deductible charitable contribution, no guarantees can be made on project outcomes, other than "Best Effort." Students are provided a working budget of \$1,000 to cover direct expenses.

## Assessment

The project requires several deliverables during the semester. These include the following:

1. **Weekly deliverables:** Each week the team briefs the **faculty Advisor** on the weekly deliverables. The subject matter focuses on:
  - State the project - a brief description of the goal of the project.
  - Past - a very brief recap of last week's project status. Also present items from the previous week identified by the instructor as needing revision or greater depth.
  - Present - current progress on the weekly deliverables including significant achievements and major problems.
  - Future - near term plans. Include action items as suggested by the instructor during the current presentation
1. **Midway status Presentation:** This is an oral update on your project. Attendees include fellow classmates and perhaps a few experienced designers. Students are given 20 minutes to present their progress plus 5 minutes for questions and answers. The majority of the presentation's time is spent in discussing the approach and the work plan for the balance of the semester. Students are required to include a few words on the major obstacles that they foresee.
2. **Midway status Report:** Each group delivers an interim status report to the class. This "Midway status presentation" consists of a relatively informal presentation and information exchange with class members, with an emphasis on peer scrutiny and feedback on project direction, status and goals.
3. **Final presentation:** Each group prepares and delivers a professional-quality final oral presentation. Attendees at the final oral presentation will include members of the ME and MET capstone classes, the instructors, M&IE faculty advisors, and any other interested individuals. The demonstration of a working prototype is strongly encouraged at the Final Design Review.
4. **Written Report (final report):** Each design team prepares one professional-quality written report documenting this semester. Draft chapters are collected throughout the semester. The compiled written formal report is due during the last week of class (before finals week.)
5. **Poster Board Display:** Each team creates a 42" x 36" poster board display to explain their project. Include a brief description of your problem and a brief description of your proposed solution. The poster should be primarily composed of visual images with explaining captions. The viewer should quickly understand what your project problem was and how you solved it.
6. **Coach's Evaluation:** This part of your grade is based on feedback from coaches and sponsors or clients.

7. **Peer Evaluations:** Since the class is divided into groups, an overall grade is determined for the group performance. Sometimes it is necessary to make differentiations within the group to make sure the individual grades reflect each person's contributions. Each group is to submit a group self-evaluation.

## Results

Two surveys were conducted at the end of the semester. The first survey is designed to measure the team effectiveness and performance. The second part of the survey is designed to measure individual performance and contribution to the team's activities. The sample consisted of 20 students enrolled in the course.

A summary of the team assessment survey is shown in Table 1. The survey response was on a scale of 0 (low) to 5. (High) The results show that students in the course have very positive experience working as a team. The results show that there is high degree of synergy attained and team members developed skills and ideas through interaction with others. It also indicates that the final design could not have been achieved by dividing project and working individually. The results show that students work well together to set and meet team goals; encourage participation among all team members; listen and cooperate; share information and help reconcile differences of opinion when they occur.

**Table 1 -Team Effectiveness Evaluation Rubric**

Category	Min	Ave	Max
<b>1. Roles and responsibilities</b> (establishing and performing assigned responsibilities to team)	3	4.6	5
<b>2. Attitude and climate</b> (creating and maintaining supportive team climate)	3	4.4	5
<b>3. Resource management</b> (assessing, accessing, and using team resources to achieve goals)	3	4.3	5
<b>4. Operating procedures</b> (establishing and using processes to ensure effective team interactions and productivity)	3	4.4	5
<b>5. Synergy</b>	3	4.4	5
Minimum	3	4.3	5
Average	3	4.4	5
Maximum	3	4.6	5

Table 2 shows a summary of the results obtained from the survey about student perception. In this assessment, each individual is to evaluate all group members (including themselves) using a narrative format. For each member (including themselves), they elaborate on important

contributions to the project that should be recognized. Also students explain how that member performed in the team structure. For example did a person show initiative, did just "what they were told", or was just a drag on the group? Did the person work consistently throughout the semester or did they just try to make up for lost time at the end?

As can be seen from the results presented in Table 2, each member of the team has contributed equally to the design project and submitted their assignment in a timely fashion. The results also show that the students have worked constructively within a team and responded in a responsible and professional manner.

**Table 2 - Individual Team Members' Evaluation Form**

<b>Team Member's Name</b>	<b>Min</b>	<b>Ave</b>	<b>Max</b>
<b>Attendance at the group meetings</b> 100-always 0-never	80	97	100
<b>Easy / Hard to get in contact with</b> 100-very easy 0-impossible	85	96	100
<b>Completing his/her part of the project</b> 100-always 0-never	80	97	100
<b>Finishing assignments in a timely manner</b> 100-on time or earlier 0-always late	90	97	100
<b>Collaboration with other team members</b> 100-commendable 0-none	80	94	100
<b>Overall grade</b> (result of the above, but in the letter form: A, B, C, D, or F with +/-)	B	A	A
<b>Recommended/Not to stay on the team</b> (n/a for this year, but please fill-in)	Yes	Yes	Yes

**Student experience and findings**

Students experience in the senior design industry-sponsored projects has been very positive. Students enjoyed the experience of working on a "real-world" problem, mentoring and feedback from professional engineers and access to company resources where appropriate. The experience has enabled students to be a part of the intellectual process of real-world applications, instill a sense of fulfillment and confidence, and impart life-long benefits. It has aided in preparing students for advanced degrees. Also, of particular importance is how these

experiences help to make better engineers and lead to a broad range of successful career paths in academia and industry.

### Examples of the projects

- 1. Air Bearing Tester:** The goal of this Capstone Project is to design and build a working air bearing tester for the corporate sponsor, ASML, by the end of the second semester. This air bearing tester is used by ASML to determine the air film stiffness of a hydrostatic air bearing as shown in Figure 1. The tester applies a range of push and pull forces to the bearing and the resulting air film height and flow rate of air are measured. Using these values, force versus displacement curves are generated and then differentiated to determine the film stiffness for the bearing.

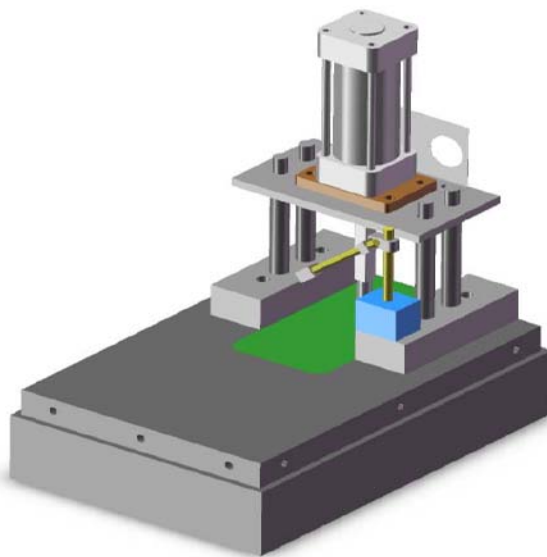

Figure 1: air bearing tester

- 2. Ground Resonance Demonstrator** - Sikorsky Aircraft has sponsored a Senior Design Team to develop a concept that will demonstrate a phenomenon known as ground resonance. This concept will eventually be brought into the production standards of the company. The primary goal is to design and build a portable bench top demonstrator with a real-time manual adjustment of the landing gear dampers. This adjustment will produce or eliminate ground resonance. The final product will be used as a training tool for newly hired engineers at Sikorsky Aircraft to demonstrate the effect of ground resonance in the helicopter industry as show in Figure 2.

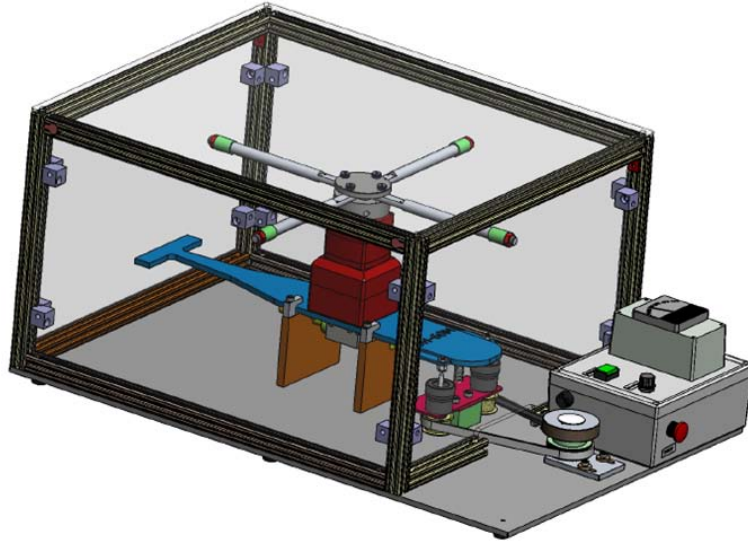

Fig. 2 – Ground Resonance Demonstrator in the helicopter industry

3. **Design a dicorrhinic model that Simulates Normal Human breathing** - The objective of this project is to determine the amount of kaolin released and possibly inhaled during use of QuikClot Nosebleed hemostatic gauze. Team III has designed and will build an apparatus to perform this task as shown in Figure 3. The device will replicate the human nasal passageway as well as simulate the normal breathing of adults and children. The kaolin inhaled into the simulated lung filters during one hour of product usage must be measured and quantified. Particle size and distribution of kaolin /binding agent (glycerol) conglomerates must then be determined. Finally, the amount of kaolin without binding agent will be quantified. The results of the test will be compared to OSHA Permissible Exposure Limits.

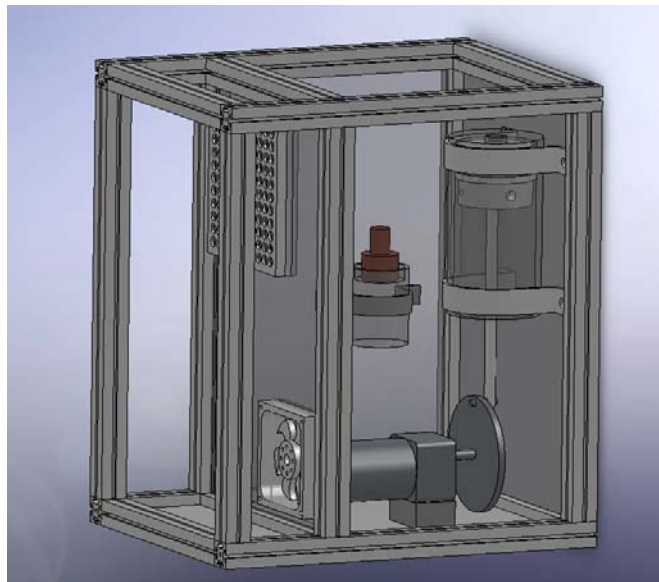

Figure 3 Dicorrhinic Model



## **Design Projects Poster**

Each design team in the capstone design course is required to prepare a display that includes a poster describing the team's goal and accomplishments which can stand alone. When the venue permits, students are encouraged to include a demonstration of their work.

The purpose is to design a team poster that will be used to introduce a new audience to the ME program, projects, and students. It also encourages teams to give explicit thought to what they are accomplishing. Furthermore, it provides experience with a different form of communication: presenting the work in a largely graphical form and discussing the project with a small audience.

## **Conclusions**

The mechanical engineering program has introduced successful industry-sponsored projects into a capstone design course. The collaboration with industry has improved and enhanced the academic excellence and integrity of the program. This initiative has raised over \$20,000 through company gifts in the first year that has been used to support these projects and the entire design program. It has been rewarding experience for the students and the faculty advisor. The student learning experience has been enhanced by interacting with practical engineers and managers. The experience has been a Win-Win scenario for the students and the Industry partner. The students have the opportunity to work on a practical design project and to interact with outside engineers. The companies also have the ability to work directly with some of our brightest and most capable students, providing them an opportunity to identify potential new hires.

## **Bibliography**

- [ 1] Dym, C. L., A. M. Agogino, O. Eris, D. D. Frey, and L. J. Leifer. (2005). "Engineering Design Thinking, Teaching, and Learning." *Journal of Engineering Education*, 94(1): 103- 120.
- [2] Dutson, A. J., R. H. Todd, S. P. Magleby and C. D. Sorenson. (1997) "A Review of Literature on Teaching Design through Project-Oriented Capstone Courses," *Journal of Engineering Education* 76(1): 17-28.
- [3] McKenzie, L., M. Trevisan, D. Davis, and S. Beyerlein. (2004). "Capstone Design Courses and Assessment: A National Study." *American Society for Engineering Education Annual Conference*, Salt Lake City, UT.
- [4] Davis, D., M. Trevisan, L. McKenzie, S. Beyerlein, P. Daniels, T. Rutar, P. Thompson, and K. Gentili (2002). "Practices for Quality Implementation of the TIDEE 'Design Team Readiness Assessment'". *Annual Conference of the American Society for Engineering Education*, Montreal, QE.
- [5] Conn A.F and W.N. Sharpe Jr. *An Industry-Sponsored Capstone Design Course*. Presented at the 1993 ASME Design Education Conference, March 24-26, 1993.
- [ 6] Magleby, S.P. et al. *Selecting Appropriate Industrial Projects for Capstone Design Projects*. *Int. J. Engng Ed*, Vol 17, Nos 4 and 5, pp. 400-405, 2001.
- [7] ABET, (2006). "Criteria for Accrediting Engineering Programs," Baltimore, MD, [www.abet.org](http://www.abet.org).

## **Biographical Information**

Ismail I. Orabi, Professor of Mechanical Engineering received his Ph.D. from Clarkson University, and his M.S. degree from the State University of New York and B.S. from Cairo

Institute of Technology (now Helwan University), all in mechanical engineering. He has published over 25 technical articles in refereed journals and conference proceedings. His research interests include theoretical and computational investigation in the area of mechanical vibrations and dynamic systems and control. Professor Orabi has received a number of research awards from the State of Connecticut and United Technologies. He has established two Laboratories: the Materials Testing Laboratory sponsored by the [National Science Foundation](#), and the Engineering Multimedia Laboratory funded by AT&T. He is a member of [ASME](#) and [ASEE](#).

### **Contact Information**

Ismail I Orabi, Ph.D., Professor of Mechanical Engineering, Mechanical, Civil & Environmental Engineering Department, 300 Boston Post Road, University of New Haven, West Haven, CT 06516, Phone: 203 932 7144, [iorabi@newhaven.edu](mailto:iorabi@newhaven.edu)