

AC 2009-1806: COLLABORATIVE DEVELOPMENT OF REMOTE ELECTRONICS LABORATORIES: THE ELVIS ILAB

Adnaan Jiwaji, MIT

Adnaan Jiwaji is a Masters of Engineering graduate in Electrical Engineering and Computer Science from the Massachusetts Institute of Technology. His thesis was development of remote laboratories for Africa with iLabs. Currently he is a Software Engineer for the Clusters and Parallel Storage Technology group at Oracle.

James Hardison, MIT

James Hardison is a Research Engineer with the Center for Educational Computing Initiatives at MIT. He holds a B.S. in Electrical Engineering and Computer Science from MIT. Presently, he is involved with the management and development of online laboratories at MIT as well as the design and development of the iLab Shared Architecture. He is a member of the IEEE.

Kayode P. Ayodele, Obafemi Awolowo University, Ile-Ife, Nigeria

Kayode Ayodele received his BSc. and MSc. degrees in Electronic and Electrical Engineering from Obafemi Awolowo University Nigeria, where he is presently concluding his PhD. His research interests include the role of emerging technologies in engineering education, applications of sensors with emphasis on accelerometers, and NARX and state space methods for behavioral modeling of non-linear systems.

Sandy Stevens Tickodri-Togboa, Makerere University

Sandy Stevens Tickodri-Togboa is Professor of Engineering Mathematics at the Faculty of Technology, Makerere University. He holds B.Sc. (Hons.) in Electrical Engineering, M.Sc. (Hons.) in Radio Engineering, PhD (Technical) in Electrical Communications Engineering.

Presently he is the Deputy Dean (Finance & Administration), Head of Engineering Mathematics and a Member of the University Senate. He is the Principal Investigator on the iLabs (iLabs@Mak) Project, Faculty Mentor on the Vehicle Design Summit (VDS) Project, and Team Leader on the Academic Records Management System (ARMS) Project, all at Makerere University. His Research areas include Information Communications Technology (ICT), Geographic Information Systems (GIS), Mathematical Modeling and Applied Engineering Hydrology.

Previously, he held positions of Deputy Dean, Faculty of Technology from 1999 to 2001; Deputy Chairman of Board of Directors of Uganda Electricity Board (UEB) between 1997 and 2000 and University Secretary of Gulu University in Uganda from 2001 to 2003.

Alfred Mwambela, University of Dar-es-Salaam

Alfred Mwambela received his B.Sc. degree in Applied Physics in 1988 from the University of Dar-es-Salaam, Tanzania, his M.Sc. degree in Electronics in 1993 from Durham University, UK and the PhD degree in Industrial process tomography in 1999 from the University of Dar-es-Salaam. He has been with the department of electronic and communication technologies of University of Dar-es-Salaam from 1989. His research interest has been in computing technologies system development. Currently he is involved in development of online laboratory experiments.

V. Judson Harward, MIT

Dr. Judson Harward is Principal Research Scientist and Associate Director at MIT's Center for Educational Computing Initiatives. He is architect and project manager for the iLab Shared Architecture. He played the same role for the Athena Muse 2 cross-platform multimedia

environment and has directed research projects focused on intelligent distributed sensor and decision support systems. He co-teaches one of the large undergraduate computing courses at MIT. His research interests include object-oriented application design and distributed multimedia.

Jesús A. del Alamo, MIT

Jesus A. del Alamo received a telecommunications engineer degree from the Polytechnic University of Madrid, Spain in 1980 and MS and PhD degrees in electrical engineering from Stanford University, Palo Alto, California in 1983 and 1985, respectively. From 1985 to 1988 he was with NTT LSI Laboratories in Atsugi (Japan).

He has been with the Department of Electrical Engineering and Computer Science of Massachusetts Institute of Technology since 1988 where he is currently Donner Professor and MacVicar Faculty Fellow. His current research interests are on microelectronics technologies for communications and logic processing. He has a particular interest in Si LDMOS, CMOS, GaAs PHEMTs and GaN HEMTs for RF power applications and in InGaAs HEMTs as a beyond-the-roadmap semiconductor logic technology. He is also active in online laboratories for science and engineering education.

Professor del Alamo has received several teaching awards at MIT: the Baker Award, the Edgerton Junior Faculty Achievement Award, the Smullin Award, and the Bose Award. He was an NSF Presidential Young Investigator. He is a member of the Royal Spanish Academy of Engineering and Fellow of the IEEE. He currently serves as Editor of IEEE Electron Device Letters.

Bryant Harrison, MIT

Bryant Harrison is a Master of Business Administration degree candidate at Harvard Business School. He received his Bachelor of Science (2007) and Master of Engineering (2008) degrees in Electrical Engineering and Computer Science from MIT. He led a team in Kenya teaching information technology and entrepreneurship in 2004 through the MIT Africa Internet Technology Initiative, and coordinated the activities of the program in Africa from 2005-2008. In 2006 he worked on the OpenAfrica project with Microsoft iCampus to assess the effectiveness of educational technologies in universities and high schools in East Africa. His current research interests include educational technologies and developmental entrepreneurship. Previous research and industry experiences include work in medical devices and bioelectronic instrumentation.

Samuel Gikandi, MIT

Samuel Gikandi was born and raised in Kenya through his high school years. He got his bachelors and masters degrees in EECS from MIT in 2006. He worked with the iLab Project during his Masters year. He currently builds electronic trading systems at Morgan Stanley.

Collaborative Development of Remote Electronics Laboratories: The ELVIS iLab

Abstract

Remote laboratories represent a significant value to engineering curricula in a variety of cases. Whether it is a complement to a hands-on experience or a substitute when a traditional lab is not feasible, remote laboratories can be a valuable educational resource. Since 1998, the MIT iLab Project has worked to increase the quality and availability of remote laboratories. Using the iLab Shared Architecture, developers of new labs can leverage a set of generic support functions and then share those labs easily and with minimal administrative cost. More recently, the iLab Project, in partnership with Obafemi Awolowo University in Nigeria, Makerere University in Uganda and the University of Dar-es-Salaam in Tanzania and in coordination with the Maricopa Advanced Technology Education Center (MATEC), has focused on building iLabs around the National Instruments Educational Laboratory Virtual Instrumentation Suite (ELVIS) platform. The ELVIS is a low-cost, small-footprint unit that contains most of the common test instruments found in a typical electrical engineering lab. By coupling the ELVIS with iLabs, a variety of remote electronics laboratories can be built and shared around the world. Using this common hardware/software platform, participants in the iLab Project at different levels of the educational spectrum have developed experiments that meet their individual curricular needs and are able to host them for use by other peer institutions. Not only does this increase the variety of ELVIS-based iLabs, but it also spurs the creation of teams that can then build other, more diverse iLabs and substantively participate in project-wide collaborative development efforts. Through such coordinated efforts, iLabs can provide rich practical experiences for students in areas not previously possible at institutions across the educational spectrum.

I. Introduction

The iLab Project is dedicated to the prospect of increasing the quality and availability of Internet-accessible remote laboratories. Remote laboratories, or iLabs, enable real laboratory instrumentation to be accessed remotely through the Internet, allowing students and educators to carry out experiments from anywhere at any time. In contrast to a traditional lab that requires multiple instrument stations to be placed in a relatively large physical space and attended by trained staff, an iLab can provide use of a single laboratory instrument, housed in a closed research lab, office or closet, to many students. This enables iLabs to provide laboratory experiences at a relatively low cost per user. Further, since users of an iLab do not have to be physically located at the laboratory, iLabs can be a means of providing broad access to rare, exotic or dangerous experiments such as those taking place in a nuclear reactor.

The iLab Project at MIT was started in 1998 by Prof. Jesús del Alamo as a response to a specific educational problem¹. Prof. del Alamo, while lecturing an introductory course in microelectronics, lamented the entirely theoretical nature of the course. A traditional, hands-on microelectronics laboratory was not feasible due to the cost of providing the necessary test instrumentation for over a hundred students. However, one such instrument did exist in Prof. del Alamo's research lab. With the help of an undergraduate student, a web-based interface for this

instrument was developed which provided Prof. del Alamo's students with access to a completely new laboratory experience.

Since then, a number of iLabs have been developed by faculty in a variety of engineering fields and made available to students across the globe²⁻⁴. The iLab Project has expanded its focus to include the development of a standardized, open-source architecture for the development of remote labs. This architecture, known as the iLab Shared Architecture and initially released in 2004, simplifies the development of remote laboratories by providing a set of generic utilities and a distributed platform for remote labs to be easily shared⁵. This architecture has been adopted by a number of universities, greatly expanding the number and variety of iLabs available to a given user⁶.

Due to the scalable and economically efficient nature of iLabs, they have sparked significant interest from various institutions. One such case is a partnership the iLab Project has had with three African universities: Obafemi Awolowo University in Nigeria, Makerere University in Uganda and the University of Dar-es-Salaam in Tanzania. While enjoying talented instructors and engaged students, such institutions often find it difficult to purchase and maintain costly or delicate lab equipment. Here, iLabs allows individual African universities to deploy experiments that they are well suited to maintain and share them easily with other universities. Thus, students are able to take advantage of a broad set of iLabs hosted from both on and off the continent.

In a separate partnership, the MIT iLab Project has been working with the Maricopa Advanced Technology Education Center (MATEC) to develop a remote laboratory in support of an electronics technician curriculum focused at American community college students. In this case, the institutions adopting the new curriculum can do so at a lower cost as certain laboratory assignments will be performed using iLabs hosted by MATEC. Additionally, the fact that students do not have to be physically present in the lab to perform certain assignments is well received at institutions that serve part-time, commuter or distance learning students. Regarding both partnerships, not only has there been significant development within their own scopes but they have influenced the direction of the iLab Project more generally.

Both of these efforts were initially focused on iLab development with the National Instruments Educational Laboratory Virtual Instrumentation Suite (ELVIS) platform. The ELVIS is a relatively inexpensive, small-footprint instrument that contains a number of common electronics test and measurement tools such as function generators, oscilloscopes and dynamic signal analyzers⁷. iLabs based on the ELVIS can be easily exported to partner universities as they are based on a common platform even though individual iLabs may focus on different subsets of the ELVIS's functionality. This common platform also increases the degree to which development at one institution can be shared with others.

This paper will provide a survey of the work that the MIT iLab Project has done with the ELVIS as a basis for lab deployments at partner institutions. It will look at how these iLabs have been adopted at the specific partner institutions identified and at how communities of educators and developers have coalesced around them. Following from that, this paper will explore how the work of these communities has increased the value of iLabs and made significant contributions to the broader iLab Project.

II. ELVIS Development at MIT

The iLab Shared Architecture (ISA) provides a common framework on which laboratory instrumentation can be integrated to create remote laboratories. The ISA, detailed in Figure 1, is a three-tiered architecture consisting of a lab client, a Service Broker and a lab server⁵.

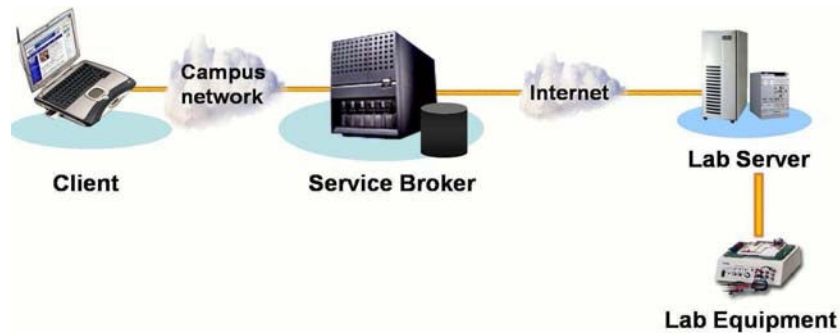

Figure 1: Topology of the iLab Shared Architecture.

The Service Broker is a middleware application that provides a set of generic administrative services as well as a deployment mechanism for individual iLabs. For batched-type iLabs - those that do not require real time control - the Service Broker also acts as a relay for all communications between a lab client and a lab

server. The lab client provides the user interface through which students interact with the experiment, providing a representation of the equipment they are using along with a means of supplying experiment parameters and viewing data. Students log in to a Service Broker, which is normally located on their campus, in order to gain access to and launch iLab lab clients. The lab server, collocated with the lab instrumentation, is responsible for receiving experiment submissions, translating them into instrument specific commands, executing those commands and returning experiment data. For the purpose of load balancing, batched iLab lab servers contain a queuing mechanism to run the experiments submitted on a first in, first out basis. The iLab Shared Architecture relies on web services for communication between the lab client, Service Broker and lab server. For communicating lab-specific information between a lab client and a lab server, a lab-specific XML encoding is used.

Since the release of the iLab Shared Architecture, a number of iLabs have been developed utilizing a broad variety of laboratory instrumentation²⁻⁴. The range of instrumentation used spans from industry-grade test and measurement equipment to ad hoc collections of sensors and input devices. On one end of the spectrum, the instruments are highly accurate and can perform specific tasks reliably but can be quite expensive. On the other are lower cost systems that, while also well featured, may be tailored to a specific type of experiment and may be hard to replicate. Striking an attractive balance between these extremes is the Educational Laboratory Virtual Instrumentation Suite (ELVIS) hardware platform developed by National Instruments.

The ELVIS, shown in Figure 2, offers the functionality of the instruments typically found on an electronics workbench in a single, relatively low-cost, small-footprint device. The ELVIS includes a basic function generator, an arbitrary waveform generator, variable and fixed power supplies and digital I/O as well as an oscilloscope, a multimeter and frequency domain measurement functionality in a unit that costs less than US\$3,000.00. These instruments can be easily controlled using LabVIEW, a graphical programming environment also developed by



Figure 2: The National Instruments ELVIS electronics workbench.

National Instruments. Drawn by the instrument's various capabilities, ease of control and relatively low cost, the iLab Project at MIT has built a number of iLabs based on the ELVIS.

The first iLab built at MIT using the ELVIS was developed in 2005 by Samuel Gikandi as part of his Master of Engineering thesis⁸. It served as a proof of concept for integration of the ELVIS into the iLab framework and laid the foundation on which future ELVIS development has taken place. This iLab exposed two of the hardware instruments on the ELVIS, the Function Generator (FGEN) and the Oscilloscope (SCOPE), enabling students to perform basic time-

domain measurements on electronic circuits. The lab client developed by Mr. Gikandi was a modified version of the Java client used in the Microelectronics Device Characterization iLab². The client, detailed in Figure 3, shows the schematic diagram of the circuit connected to the ELVIS. The user can click on the FGEN and SCOPE terminals in this diagram to input experiment parameters. The lab server for this iLab is also based on its microelectronics-based counterpart with a LabVIEW application providing an interface between the reused iLab lab server code and the ELVIS.

This first revision ELVIS-based iLab exposed a minimal amount of the functionality available on the ELVIS. It allowed for experiments with circuits that had one analog input and one analog output. Besides this, the student is not given any flexibility in the design of the circuits. However, this work was critical in laying a foundation for future modifications and enhancements to the ELVIS iLab.

One such modification to the initial ELVIS iLab was the focus of a Master of Engineering thesis by Bryant Harrison⁹. Building upon the functionality exposed by Mr. Gikandi, Mr. Harrison introduced computer controlled switching into the ELVIS iLab, allowing the construction of circuits that could have certain components switched in or out. This enabled an entirely new mode of experimentation within the ELVIS iLab. Rather than being limited to only observing the behavior of a static circuit-under-test, students could also manipulate the circuit to produce varying behaviors. The lab client and interface elements that control this functionality are shown in Figure 4. For this work, a National Instruments SCXI-1169 switch unit was used, enabling easy integration with the software control elements previously developed for the ELVIS.

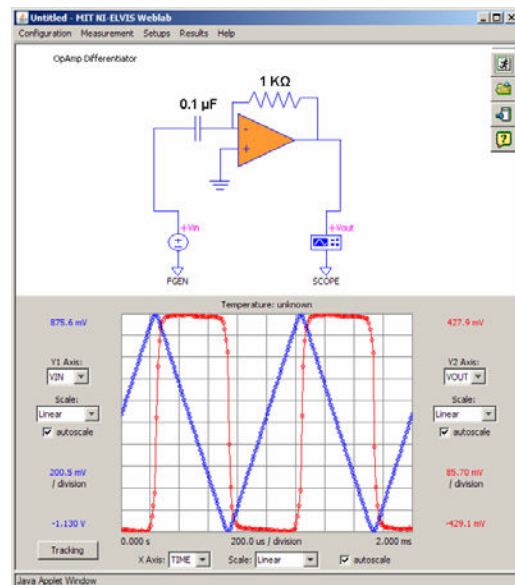

Figure 3: The lab client developed by Samuel Gikandi to run experiments on the ELVIS. An experiment run on a differentiator circuit with a triangular wave input is detailed.

At the same time, a separate set of modifications were aimed at increasing the range of experiments possible on the ELVIS iLab. This work was the focus of a Master of Engineering thesis by Adnaan Jiwaji. Specifically, Mr. Jiwaji added the ELVIS's Arbitrary Waveform Generator (ARB) and Bode Analyzer (BODE) instruments to the initial iLab's functionality set¹⁰. The ARB instruments are sources that are able to generate a wider variety of input waveforms than the more basic Function Generator, including those defined by a mathematical function, a user-supplied data vector or an audio file. Further, the ARB channels could be used independently and simultaneously with the Function Generator, enabling students to describe a wide variety of inputs to a circuit-under-test. As shown in Figure 5, the inclusion of the Bode Analyzer to the ELVIS iLab enabled students to perform frequency-domain measurements in addition to the previously available time-domain measurements. As with the inclusion of switching to the initial ELVIS iLab revision, the addition of the ARB and BODE instruments to the ELVIS iLab enabled new types of experiments to be performed remotely - all using a common hardware platform.

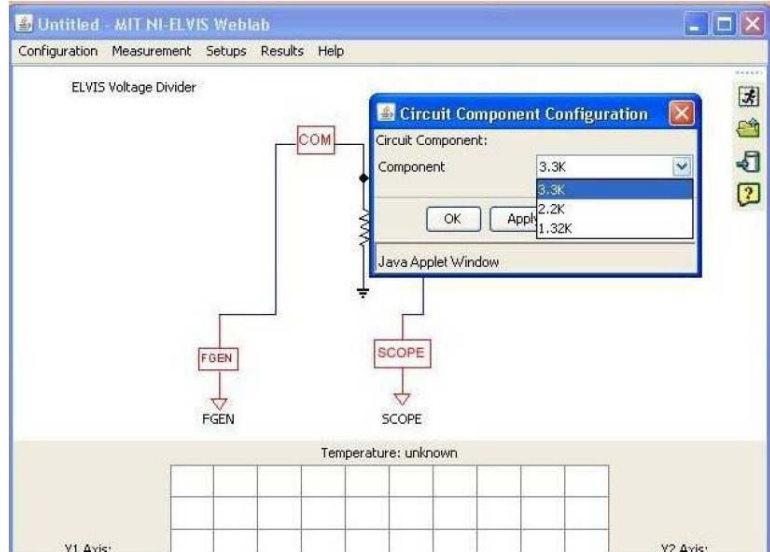

Figure 4: Addition of a switch allows users to choose the component value that they would like to place in the circuit.

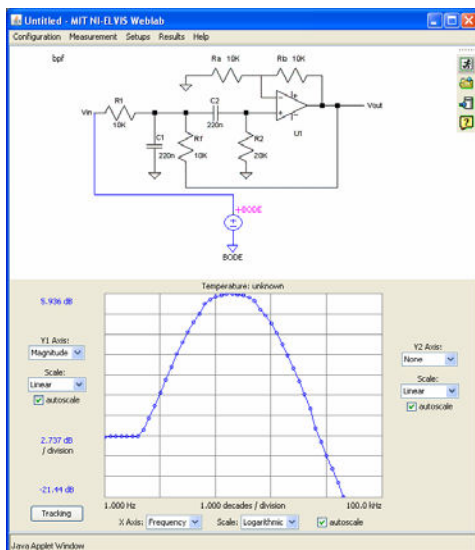

Figure 5: Magnitude plot of a Sallen-Key band pass filter as measured using the ELVIS iLab.

The work put into iLabs based on the ELVIS has had a direct impact on electrical engineering education at MIT. The initial revision of the ELVIS iLab has been increasingly used in MIT's introductory circuits and electronics course - a part of the core curriculum for undergraduate students in the university's Electrical Engineering and Computer Science program. This iLab, used alongside MIT's Microelectronics Device Characterization iLab and Dynamic Signal Analyzer iLab^{2, 3}, enables students to perform DC, time-domain and frequency-domain measurements - providing a broad view on the behavior of circuits and devices.

Building upon the work of Mr. Harrison and Mr. Jiwaji, a new ELVIS-based iLab was built with the goal of capturing the majority of the functions of the platform. This iLab, titled the ESyst Analog Systems iLab and deployed in the Fall of 2008, was developed by the MIT iLab Project in partnership with the Maricopa Advanced

Technology Education Center (MATEC) with the goal of providing a versatile remote laboratory for electronics students. This iLab builds upon the previously described work, adding control of the variable power supplies and digital I/O lines available in the ELVIS, utilizing result analysis tools available in LabVIEW and preparing the system for use by students and instructors for credit bearing assignments.

These iLabs, each based on the ELVIS, provide different experiences to their users. This is where the versatility of the ELVIS platform is realized in the iLab framework: a wide variety of iLabs can be constructed using not just the generic functionality of the iLab Shared Architecture but also the collection of instruments in the ELVIS. The common platform of iLabs and the ELVIS can be used to develop specific remote laboratories at all institutions within the iLab Project. Development efforts can then be shared among partner institutions. This approach has encouraged strong collaboration between MIT and a number of partners in developing new software and hardware features for the ELVIS platform.

III. Adoption by Partner Institutions: The iLab-Africa Project

In 2005 a major partnership was established between MIT and three African universities to form the iLab-Africa Project. The three universities are Obafemi Awolowo University (OAU) in Ile-Ife, Nigeria, University of Dar-es-Salaam (UDSM) in Dar-es-Salaam, Tanzania and Makerere University (MUK) in Kampala, Uganda. The aim of the iLab-Africa project is to exploit the potential of iLabs to enrich science and engineering education in Sub-Saharan Africa. A feasibility study conducted between 2003 and 2004 found that electrical engineering was one of the main areas that lacked laboratory facilities at universities in sub-Saharan Africa and that iLabs were a potentially valuable addition⁶.

As a first step, this partnership enabled these universities to use existing iLabs hosted at MIT, giving students in these countries access to high cost equipment that local institutions could not afford. Over the course of this project, nearly 700 students at UDSM, OAU and Makerere University have used the MIT-hosted Microelectronics Device Characterization iLab⁶. However, effective implementation of iLabs in Africa has been impeded by limited Internet connectivity. East Africa does not have a fiber optic cable connecting it to the rest of the world; hence Tanzania and Uganda have to rely on slow and expensive satellite connections. These countries are bandwidth starved, as they usually cannot afford to pay for large bandwidth connections. For this reason, while MIT-hosted iLabs are a valuable resource for African students, they are not the best solution.

In response to this, new labs that integrate low cost equipment that could be housed locally at each university were created. The platform chosen for this purpose was the ELVIS. The ELVIS is ideal in this case because of its versatility and its relatively low cost, enabling universities to easily provide a complete platform on which to build an iLab. Being hosted on campus, these iLabs can be accessed using only campus local area networks (LANs) which are more advanced than the upstream connections to the Internet. In this case, the performance of locally-hosted iLabs is superior to those hosted elsewhere on the Internet. It is also more convenient as they have access to the hardware and can easily implement the experiments they would like to run

instead of coordinating with a physically distant partner every time they need to change the setup.

Each of the partner universities has adopted the platform to a different extent based on its curriculum needs and development strengths. The following sections will provide a brief overview of the work that is happening at each of these partner universities.

III. a. Obafemi Awolowo University

Obafemi Awolowo University is one of the oldest universities in Nigeria. Although the university prides itself as being one of the best in the country, it has suffered from the same problems of neglect, poor funding and exodus of staff that has plagued other Nigerian universities for decades. As a result, science and engineering courses are typically characterized by inadequate experimentation components. In many departments, experiments that are stipulated in the curriculum are often skipped either because the necessary resources are unavailable or inadequate or because there are too few technical staff in the laboratories. The university has tried to find ways of changing this situation, and one of these ways is the adoption of iLabs.

To date, students in the departments of Physics and Electronic and Electrical Engineering of the university have used the MIT Microelectronics Device Characterization iLab for three academic sessions. They have also used two laboratories developed locally at the university: the OpAmp Lab and the Logic Lab. The OpAmp Lab allows students to remotely configure a simple operational amplifier circuit based on the Dozen-Impedance configuration detailed in Figure 6 and carry out various tests on it. The Logic Lab allows students to carry out basic digital electronics experiments.

Initially, the Logic Lab had a backend system-under-test that had a few simple digital chips. This has evolved into a system that contains an Altera DE1 Development Board with an Altera Cyclone II 2C20 FPGA to allow students to carry out VHDL and FPGA experiments on it. This hardware setup is shown in Figure 7. The new Logic Lab marks the first time students in the department of Electronic and Electrical Engineering will be able to carry out experiments on FPGAs.

The OAU development team saw a functional switching matrix as an important part of any experimentation system, since it

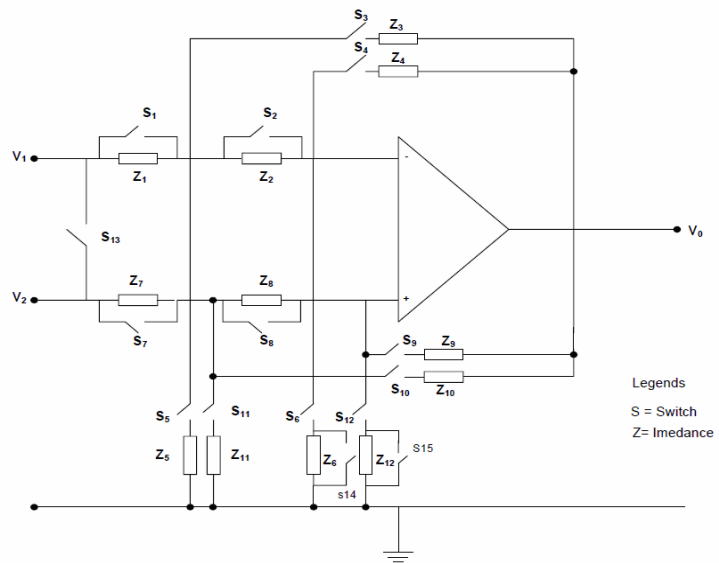

Figure 6: The Dozen-Impedance configuration upon which the OpAmp Lab system under test is based.

allows remote recombination of system parts. They felt that the ELVIS could be enhanced by the integration of a switching matrix. A small switching matrix was developed based on a PIC18F452 microcontroller and six MAX4664 Quad SPST analog FET switches. The initial plan was to couple the switching matrix to the ELVIS so that only a single line of communication between the lab server and the system-under-test would be needed. However, that plan was shelved in favor of an arrangement where the switching matrix had a different line of communication with the server using the USB port. This avoids a case where switching matrix commands can contribute to a bottleneck in communication with the ELVIS. Prompted by doubts about its long term reliability and scalability, this switch was upgraded to a National Instruments SCXI-1169 switch array similar to the one used at MIT. The SCXI-1169 was connected to the server through the USB port and controlled through a C# Switching Matrix Service which ran independent of the main queuing and execution logic on the lab server.



Figure 7: The new Logic Lab based on an Altera DE1 Development Board.

OAU's OpAmp Lab and the first generation Logic Lab both used the ELVIS hardware platform in the same way. As described in Figure 8, a small system under test was set up on the ELVIS board. Measurements of various parameters in the system were carried out by programmatically accessing ELVIS functionality from the lab server, while a switching matrix allowed reconfiguration of the system-under-test.

The lab clients for the OAU iLabs were implemented as WinForm applications written in C#. One aspect of the clients that became more important than initially foreseen was the issue of how the back end was represented. The OAU team found that students' perspective of how effective

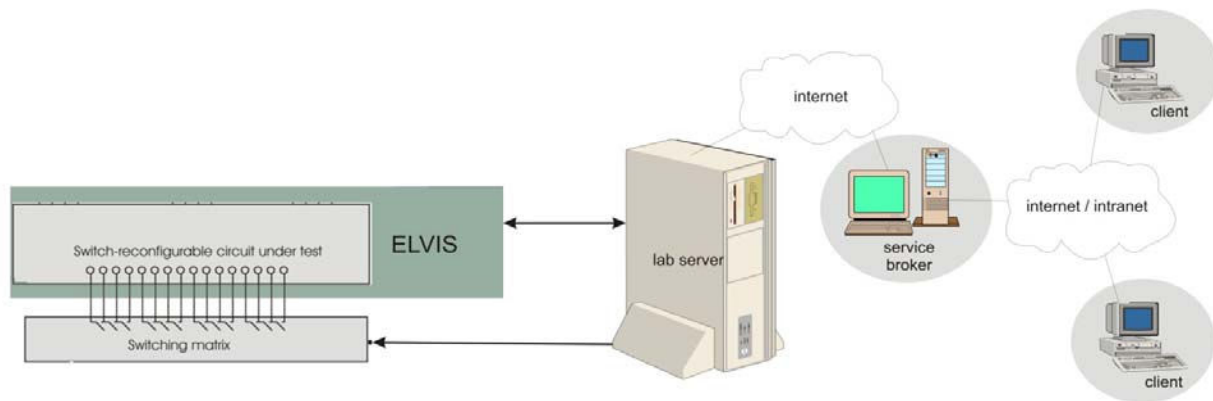

Figure 8: Architecture of the first generation OAU iLabs: a system configured on an ELVIS with the aid of a switching matrix with independent communication path to the lab server.

various iLabs were influenced most strongly by the choice of metaphor applied in depicting the back end¹¹. This was surprising given the accepted belief that Internet users prefer interface designs that allow them to work with the smallest delay. For example, when the Component Package Interface, a new “realistic looking interface” (RLI) was adopted for the OpAmp experiment (Figure 9a), students overwhelmingly said they thought the laboratory was better compared to when the same experiments were done with the traditional laboratory client (Figure 9b), even though the graphical interface was more than 100% heavier than the traditional one.

iLabs have been enthusiastically received by students at OAU. Students are usually provided with questionnaires after using any of the iLabs and their responses have generally been very positive^{11, 12}. Students’ responses consistently show that they recognize and accept iLabs as valuable supplements to real laboratories¹². Since there have been few suggested improvements to existing labs, the main focus of the OAU team for the near future should be identification and development of new iLabs along the same lines as the existing ones.

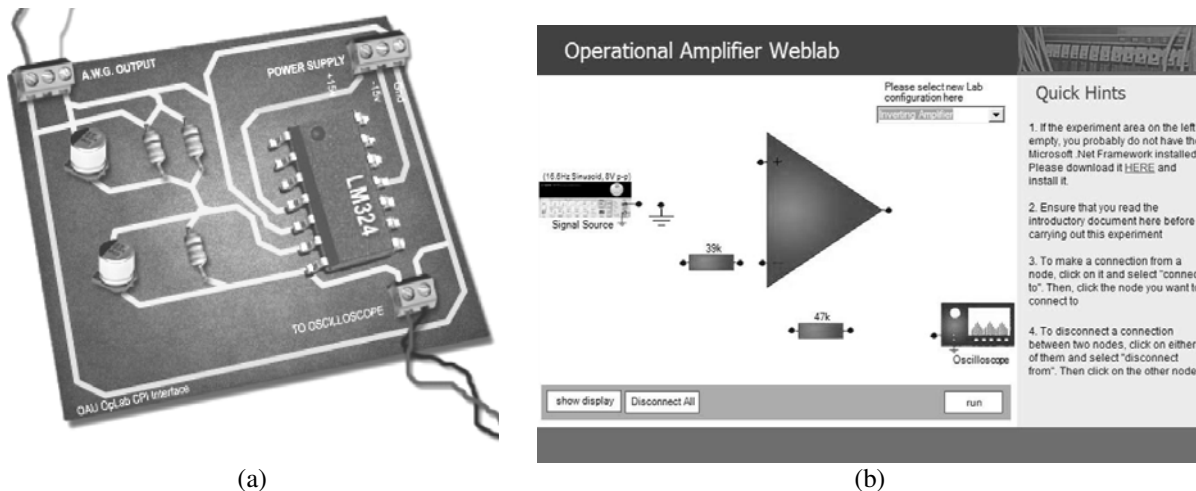

Figure 9: Two interfaces for the OpAmp Lab. A Realistic Looking Interface implementation called the Component Package Interface (a) and the original interface (b).

III. b. The University of Dar-es-Salaam

The University of Dar-es-Salaam (UDSM) is the oldest university in Tanzania. This position has allowed the university to play a key role in supporting many newly established universities in their early stages of growth. Typically, a number of science and technology institutions have relied on UDSM’s laboratory facilities to conduct experiments required in their curricula.

With increasing population, the university has been facing pressure to increase enrollment to cope with the growing number of candidates qualified to enter a higher learning institution. In turn, this has put pressure on the existing facilities which, for a number of reasons, have not expanded to reflect the increasing enrollment - a typical problem in many developing countries.

An approach to solving this problem was to exploit the power of the Internet in conducting science and engineering experiments. The university embraced the idea of online experiments proposed by Prof. Jesús del Alamo during a visit to UDSM where he demonstrated the concept of iLabs using the Microelectronics Device Characterization iLab. Since then, existing online experiments at MIT have been integrated in teaching and learning processes of some science and

engineering undergraduate programs. Additionally, a number of experiments, hosted at UDSM, have been developed based on the iLab Shared Architecture and made available to students.

Over the past few years UDSM identified a simple single-stage common emitter amplifier experiment, described in Figure 10, which was taught in one of the Electrical Engineering courses. They assembled the circuit on the ELVIS for use in classes. Based on that initial use,

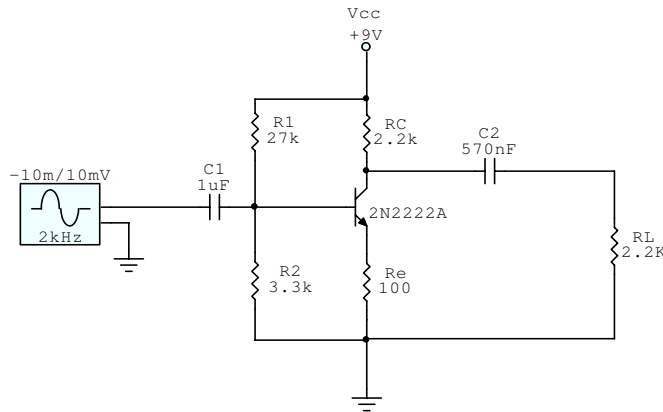

Figure 10: Single Stage Common Emitter Amplifier used at UDSM.

they saw a need to develop more features on top of the ELVIS control software they had at that time. They developed the capability of doing frequency-domain analysis almost parallel to similar development at MIT. They also needed to directly measure the DC parameters which require the ELVIS current-voltage analyzer and variable power supply integrated functions. This part of the experiment is still under development.

two other experiments: the Transistor-Transistor Logic (TTL) Device Characteristics iLab and the PN Junction Characteristics iLab. The focus of their work is to exploit the available ELVIS instruments and, where necessary, integrate additional ELVIS instruments into the iLab platform. The TTL Device Characteristics experiment also requires the ELVIS variable power supply function and the creation of a web client interface to the experiment. The PN junction experiment, which is similar in functionality to the Microelectronics Device Characterization iLab, requires the ELVIS two-wire voltage-current function which is currently not integrated into the iLab architecture. The web client interface in this case will be a slight modification to the existing Microelectronics Device Characterization lab client.

More recently two Master of Science students are working on implementing

UDSM is also serving as a center for disseminating iLabs to neighboring universities. A workshop was held in January 2008 at UDSM to increase awareness about iLabs to other universities within the country. More than 50 participants from six institutions attended. One of these universities is the Open University of Tanzania. This university offers most of its courses via distance learning and, as such, is the ideal location for deploying remote laboratories. Most of the students are located far from campus and providing a way to access different experiments remotely via iLabs would provide a much needed practical component to their engineering courses. They are currently also looking into integrating lab equipment sold by Edibon Equipment into the iLab framework.

III. c. Makerere University

At Makerere University, a research team that comprises four investigators and 14 undergraduate students chosen on merit from the Electrical Engineering Department has been built. The research in progress aims to develop experiments in the fields of digital circuit analysis, amplitude/frequency modulation, pulse code modulation and digital data transmission. These

experiments are intended for use in the first year Introduction to Digital Electronics course as well as Applied Digital Electronics, Basic Telephony and Communication Theory I, which are intended for third year students.

The team at Makerere is pioneering the integration of the ELVIS II, an updated version of the ELVIS platform, into the iLab framework. The ELVIS II was released over the summer of 2008 and, while capturing the same functionality as the original ELVIS, it allows for a wider range of



Figure 11: iLab students at Makerere University working with the ELVIS II platform and the Emona Datex board.

measurements to be made^{7, 13}. Input signals can be generated through a wider frequency range and measurements can be made at higher resolutions with a wider frequency band. Integration of the ELVIS II into the iLab framework will enable higher quality measurements to be made at a hardware cost that is comparable to the original ELVIS. Experiments are also being developed using the ELVIS Freescale board, enabling ELVIS-based microcontroller experiments, and a recently acquired Emona Datex board, shown in Figure 11, that is being evaluated for the development of telecommunications-focused iLabs.

During this work, the urgent need for iLabs has led the Makerere development team to make a slight modification to the iLabs Shared Architecture in the short term. Using the web publishing utility built in to LabVIEW, students are able to log on to a Service Broker and directly access the ELVIS instrument user interfaces supplied by National Instruments and hosted on the lab server. This has eliminated the need for the development of a separate client because the LabVIEW front panel can be used to access the hardware directly. However, this approach is more bandwidth intensive and limits the ability of these experiments to be shared across the iLab framework.

The fact that iLabs were initially an alien concept necessitated sensitization of students and staff alike about their usage and benefits. This has been done through the organization of workshops and conferences targeting students, staff and other stakeholders from within and outside Makerere University. In October 2008 the Makerere team held an exhibition at the annual technology open day as well as an exposition workshop for students. In November 2008, a students' conference was held under the theme: "Unveiling the Opportunities for Students on the iLab Framework". The involvement of other Ugandan universities such as Ndejje University, Uganda Christian University Mukono, Kyambogo University and Busitema University has the potential to broaden the spectrum of available iLabs. Prototypes from the current research will be shared with these universities, which will then be encouraged to form their own iLab teams.

IV. Adoption by Partner Institutions: MATEC and the ESyst Project

Starting in the Fall of 2007 the MIT iLab Project has been working with the Maricopa Advanced Technology Education Center (MATEC) to develop an ELVIS-based iLab for their ESyst Project. The goal of the ESyst Project is the development of a systems-oriented electronics curriculum primarily targeted at students enrolled in two-year degree programs¹⁴. These students may be full-time, part-time or distance learners.

The iLab developed for this curriculum, titled the ESyst Analog Systems iLab and detailed earlier in this paper, exposes many of the instruments built into the ELVIS for use by students over the Internet. The client interface for this iLab, shown in Figure 12, is similar to the other ELVIS-based iLabs. Students using this iLab will be able to perform a variety of measurements on an analog electronics system such as a multi-stage audio filter.

While the ESyst iLab has been deployed, feedback has been limited because the overall project is still in its development phase. However, working with ESyst curriculum developers has yielded a number of valuable lessons revolving around tailoring an iLab for different educational environments. Much of the MIT iLab Project's experience has been in developing remote labs for MIT electrical engineering students. That is, full-time students in a design-oriented program who are reasonably able to derive meaning from an abstract system such as a remote laboratory. In contrast, the target audience for the ESyst curriculum may be part-time students who are limited in the time and effort they can spend on their studies. The prototypical ESyst student will also derive the most value out of a less abstract laboratory experience that relates to their existing experience or interests. As such, the ESyst iLab not only has to faithfully expose the functionality of a traditional hands-on laboratory instrument, but it also must present the lab and experimental data in a way that is as engaging as possible. As an initial step towards this goal, an audio enabled webcam has been integrated into the lab which allows the student to both see the hardware and hear the output of the audio system-under-test as experiments are run.

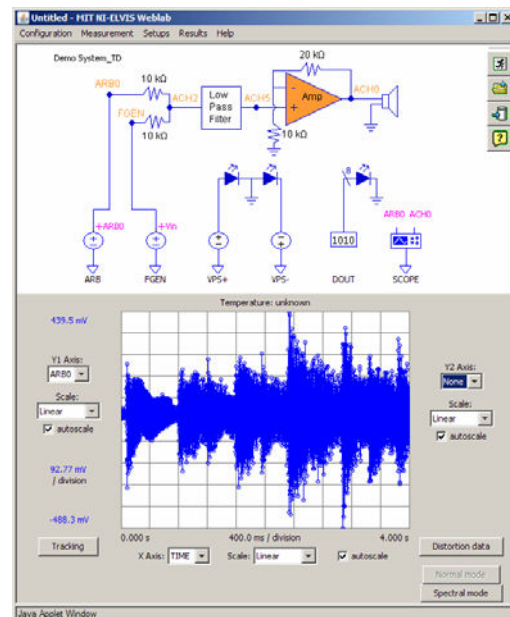

Figure 12: Lab client interface for the ESyst Analog Systems iLab.

Another challenge we have faced in developing the ESyst iLab is in instructor support. At MIT, the iLab Project enjoys the support of an established core of faculty who use iLabs regularly in their courses - exploring what can be done with existing iLabs, advocating for additional functionality when necessary and developing assignments and other curricular resources that can be adopted by their peers. Within the ESyst Project, this core has yet to be established. Not only does the ESyst iLab have to be engaging and intuitive but there must be a variety of support

materials and systems, from user manuals and tutorials to software utilities, in order to reduce barriers to adoption.

Responses to these issues are borne out of specific cases but are broadly applicable across the iLab Project. Ultimately, intuitive client design, comprehensive support materials and strong faculty support are fundamental issues in the development of any classroom technology. This is a concept that can benefit iLab partner institutions regardless of how established they are.

V. Conclusions and Future Work

In developing iLabs based on the National Instruments ELVIS, the iLab Project has established a common platform upon which a variety of remote laboratory experiences can be derived at a lower per-user cost than similar traditional labs. Each African partner university started out with the initial version of ELVIS iLab software and modified it to fit its own specific needs. Similarly, through the ESyst Project, MATEC has influenced the design of a specific ELVIS-based iLab that is tailored to their new curriculum and its target audience. It is important to note that the progress of the institutions detailed have not been limited by MIT's work. In certain cases, functionality has been added by partner institutions before or concurrently with similar work at MIT. A particular example of this can be found in the efforts around the integration of switching capabilities into ELVIS-based iLabs by the development groups at MIT and OAU. In this case, OAU began development, which prompted and inspired development by the MIT iLab Project. The work at MIT, in turn, was used by the OAU team to inform their development. Additionally, the frequency-domain measurement capability was added at UDSM and MIT in parallel.

Beyond sharing software, the cross-pollination of ideas that these partnerships foster has led to development outside the scope of ELVIS based iLabs. Through the iLab-Africa partnership, developers and project leaders from each partner institution have visited other partner institutions. This provides an invaluable opportunity not only to share ideas but to observe the strengths of each development team. More tangibly, this has led to the development of other novel iLab experiments. For example, in a visit to MIT in September 2008, a master's student from OAU developed an iLab based on controlling a robot arm. This used LabVIEW software to provide the drivers and interface for the experiment. In the case of MATEC and the ESyst Project, through the ESyst iLab, curriculum developers who would otherwise be ignorant of remote laboratories can see how they may be applied to a wider variety of laboratory experiences.

The ELVIS iLab has so far been successful not only in providing a lab experience where previously there was none but also in encouraging a generation of students and educators to work on a global collaborative engineering project. It has enabled them to work on developing laboratories for their own school and provides a chance to meet engineers working on the project from other countries. The regular visits and exchanges have encouraged the sharing of ideas and sparked numerous discussions about iLabs and engineering education in general among all members of the iLab Project.

Moving forward, the iLab Project continues its dissemination efforts, encouraging partner universities to also act as hubs from which iLabs can be made available to other universities in each area. This will enable creation of small iLab networks around the partner universities which will help those institutions secure funding from local sources to support iLab development. OAU and Makerere have been successful in securing external sources in this way, but more local sources are needed.

Within the scope of the ESyst Project, a second revision of the ESyst Analog Systems iLab is being developed. This revision will take advantage of the ELVIS II platform, which will inform ELVIS II integration efforts for other ELVIS-based iLabs. In the meantime, the first revision will tentatively be deployed in courses at both MIT and at institutions implementing the ESyst curriculum during the Spring 2009 academic term with educational assessment efforts to follow.

With respect to the iLab-Africa project, one of the main challenges faced by the project at the partner universities is iLab team building and, more broadly, retention of young faculty. Most of the developers on the iLab teams are students at undergraduate or postgraduate level. Once they graduate, many leave the universities and take their experience with them. Through the next phase of the iLab-Africa Project, there will be focus on increasing the number of graduates who pursue careers in academia at iLab partner institutions.

VI. Acknowledgments

This work has been supported in part by the Carnegie Corporation of New York, the Maricopa Advanced Technology Education Center, the Microsoft Corporation through iCampus (the MIT-Microsoft Alliance), the National Science Foundation under award #0702735, by the Singapore-MIT Alliance, the Singapore-MIT Alliance for Research and Technology and by MIT Alumni Funds (Classes of '51, '55, '60, and '72) as well as through equipment donations from National Instruments, Agilent Technologies, AMD, Hewlett-Packard and Intel.

Bibliography

- [1] del Alamo, J. A., Brooks, L., McLean, C., Hardison, J., Mishuris G., *et al.*, "The MIT Microelectronics WebLab: a Web-Enabled Remote Laboratory for Microelectronics Device Characterization", 2002 World Congress on Networked Learning in a Global Environment, Berlin (Germany), May 2002.
- [2] Hardison, J. L., Zych, D., del Alamo, J. A., Harward, V. J., Lerman, S. R., *et al.*, "The Microelectronics WebLab 6.0 – An Implementation Using Web Services and the iLab Shared Architecture", presented at the International Conference on Engineering Education and Research 2005, Tainan, Taiwan, March 1-5, 2005.
- [3] Viedma, G.; Dancy, I.J.; Lundberg, K.H., "A Web-based linear-systems iLab," American Control Conference, 2005. Proceedings of the 2005, 8-10 June 2005, pp. 5139-5144 vol. 7.
- [4] Hardison, J. L., DeLong, K., Bailey, P. H., Harward, V. J., "Deploying Interactive Remote Labs Using the iLab Shared Architecture", Frontiers in Education (FIE) Conference, Saratoga Springs, New York, October 22-25, 2008.

- [5] Harward, J., del Alamo, J. A., Choudary, V. S., DeLong, K., Hardison, J. L., et al., "iLabs: A Scalable Architecture for Sharing Online Laboratories", presented at the International Conference on Engineering Education 2004, Gainesville, Florida, October 16-21, 2004.
- [6] Harward, V. J., del Alamo, J. A., Lerman, S. R., Bailey, P., Carpenter, J, *et al.*, "The iLab Shared Architecture: A Web Services Infrastructure to Build Communities of Internet Accessible Laboratories", *Proceedings of the IEEE* Vol. 96, No. 6, June 2008.
- [7] "NI Educational Laboratory Virtual Instrumentation Suite (NI ELVIS)", <http://zone.ni.com/devzone/cda/tut/p/id/3711>.
- [8] Gikandi, S., Masters Thesis, ELVIS iLab: A Flexible Platform for Online Laboratory Experiments in Electrical Engineering, Department of Electrical Engineering and Computer Science, Massachusetts Institute of Technology (May 2006).
- [9] Harrison, B., Masters Thesis, Expanding the Capabilities of the ELVIS iLab Using Component Switching, Department of Electrical Engineering and Computer Science, Massachusetts Institute of Technology (May 2008).
- [10] Jiwaji, A., Masters Thesis, Modular Development of an Educational Remote Laboratory Platform for Electrical Engineering: the ELVIS iLab, Department of Electrical Engineering and Computer Science, Massachusetts Institute of Technology (August 2008).
- [11] Olowokere, D., Ayodele, K. P., Kehinde, L. O., Jonah, O., Ajayi, T. O., Akinwunmi, O. O., "Realistic Looking Interfaces: In Search Of The Best Ergonomic Metaphors For Remote And Virtual Laboratory Interfaces", Proceedings of the ASEE Annual Conference and Exposition, June 2008, Pittsburgh.
- [12] Ayodele, K. P., Kehinde, L. O., Jonah, O., Ilori, O., Ajayi, E. O. B, Osasona, O. O., "Development Of An Operational Amplifier Virtual Laboratory Based On ILab Architecture And NI Elvis", Proceedings of the ASEE Annual Conference and Exposition, June 2008, Pittsburgh.
- [13] "NI ELVIS II Specifications", <http://www.ni.com/pdf/manuals/372590a.pdf>.
- [14] "eSyst – Resources for Electronic Systems Technology", <http://www.esyst.org>.