

Collaborative Learning in Undergraduate Dynamics Courses: Some Examples

Francesco Costanzo and Gary L. Gray

Engineering Science and Mechanics Department
The Pennsylvania State University

Abstract

At Penn State University, we are in the midst of revising the way undergraduate dynamics is taught through an approach we call Interactive Dynamics. Interactive Dynamics is designed to engage students in a collaborative learning environment in which they also perform experiments. Students generate and analyze data, observe graphic representations of the data, and construct as well as interact with simulations. In this paper we will discuss some examples of “activities” we have created for Interactive Dynamics. These activities address not only those attributes that ABET, industry, and NSF would like to see in an engineer, but also embody the intellectual aspects of mechanics and dynamics beyond those essential skills needed to succeed in the engineering workplace.

1 Introduction

Undergraduate dynamics is a required course in many undergraduate curricula such as mechanical, civil, industrial, and aerospace engineering. In the College of Engineering at Penn State University, for example, it is taken by more than 700 students per year. Unfortunately, for many if not most students, it is not only one of the most dreaded courses in their entire curriculum, it is also a course for which some students see little purpose (*e.g.*, architectural and industrial engineers at Penn State University). We are trying to change this state of affairs at Penn State by making the course more interesting and relevant to students through the introduction of both hands-on and computer-based experiments/projects that we call “activities”. In addition, through these activities we are hoping to address some of the needs and concerns expressed by accreditation boards such as ABET and agencies such as NSF with regard to engineering education [1–4]. Details regarding what we are trying to do, how we are doing it, some of the problems we have encountered, as well as early assessment results can be found in references [5–8]. The purpose of the present paper is to present a range of the activities we have used in the course. We will do so with sufficient detail so that other instructors can use them or projects, problems, and/or experiments like them in their own courses.

2 Activities

As with a traditional dynamics course, Interactive Dynamics uses traditional “chalk-and-talk” lectures 40–50% of the time. It is the other 50–60% of the class time that profoundly differentiates Interactive Dynamics from traditional dynamics. An Interactive Dynamics class typically begins with a 15–45 minute introductory lecture in which the goal of the day’s *activity* is presented. This introduction is intended to point out any particularly important things the students should look for during the activity and to put that activity into a proper engineering context. After the introductory lecture, the activity begins.

An activity is, in essence, a project that requires the solution of a difficult problem. The level of complexity in these problems is such that it would be difficult for the students to complete them without working in teams. In fact, activities are usually substantial enough such that they cannot be completed in one class period (the course meets two times per week for 1 hour and 55 minutes each time) and their completion usually requires students to meet outside of class. We must emphasize at this point that we require written reports from the students for most activities.

Within each activity, the notion that dynamics is about equations of motion and finding loads on systems for the purpose of design is strongly emphasized. In addition, each activity requires the students to work in teams and to either take on or assign roles for each of the team members. This requires communication, leadership, and management skills that are typically not required of students in the first dynamics course. Finally, Interactive Dynamics introduces its students to an abundance of concepts and ideas that students in a traditional dynamics course never see. Again, all of these elements are intended to make the Interactive Dynamics classroom an environment which is as close as possible to the workplace that the students will experience when they leave school. On the other hand, we try not to sacrifice the notion that each activity, as well as the dynamics we are trying to teach, can be fun.

3 Examples of Some Activities

Now, on to some examples of activities we have used in Interactive Dynamics. We present each with little or no pedagogical motivation as our goal here is simply to disseminate material that can be used in the dynamics classroom. These examples are presented in no particular order.

3.1 Numerical Solution of Equations of Motion

This activity emphasizes a point that is not often made in the first course in dynamics, namely that dynamics is about equations of motion. That is, we are interested in the motion over an interval of time and not about the motion at a specific instant in time. This activity is purely “analytical” in nature and shows the students that within the first three or four weeks of the course they have the ability to derive equations of motion describing complex systems and that, with a little effort, they have the ability to numerically solve these equations to make predictions about the motion.

We begin class by doing an example problem whose solution requires the derivation and solution of an equation of motion. We convince the students that the equation we have derived is not solvable analytically and that we must resort to some other means. This provides for a transition to the numerical solution of differential equations of motion and Euler's method. We then spend 30–40 minutes introducing Euler's method and Heun's method, which is a modified, more accurate version of Euler's method.

We then present two problems to the students:

1. A two degree-of-freedom elastic pendulum; and
2. A two degree-of-freedom system consisting of a mass on one end of an elastic rod, the other end of which is pinned. The system slides in the horizontal plane on a viscous layer and is undergoing a constant torque at the pinned end. It is simply a modified version of the elastic pendulum.

3.1.1 An Elastic Pendulum

For this part of the activity, the students are given the appropriate physical parameters of the

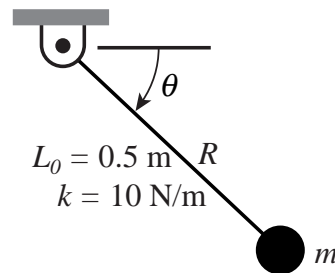

Figure 1. Diagram illustrating the elastic pendulum described in the activity.

system in the following statement (also see Figure 1),

The 0.25-kg mass, which is attached to the elastic rod of stiffness 10 N/m and undeformed length 0.5 m, is free to move in the vertical plane under the influence of gravity. The mass is released from rest when the angle $\theta = 0^\circ$ with the rod stretched 0.25 m. Assume that the rod can only undergo tension and compression and that it always remains straight as the pendulum swings in the vertical plane.

We then ask the students to:

1. Derive the equations of motion for this system and state the initial conditions.
2. Solve the equations numerically from the time of release ($t = 0$) until $t = 10$ seconds.
3. Find the maximum speed of the mass during this period of integration.

4. Determine the maximum value of R and the *first* value of θ theta when the rod becomes slack.
5. Plot R and $\dot{\theta}$ versus θ .
6. Plot the *actual trajectory* of the mass as you would see it for $t = 0$ until $t = 10$ seconds.

Parts 2–6 of this activity are all performed in Microsoft Excel. To do this, the students set up columns in Excel defining position, velocity, and acceleration at each time step. They then use the equations for either Heun’s method or Euler’s method, along with the governing differential equations, to propagate the solution forward in time. This is easily done in Excel as one can simply drag down rows of numbers to update cells based on defined equations.

3.1.2 A Whirling Mass in a Horizontal Plane

As part of the same activity in which the students analyze the elastic pendulum, they also analyze a two degree-of-freedom problem described in the following statement:

With reference to Figure 2, consider a mass of 0.25 kg sliding on the horizontal surface forming the xy -plane. The surface is covered by a film of lubricant intended to facilitate the sliding motion, but which also provides a viscous resistance to the motion. The action of the lubricant on the moving mass is equivalent to a viscous resistance force, which is proportional to the velocity of the mass and has a viscosity coefficient $c = 0.3 \text{ N}\cdot\text{s}/\text{m}$. The mass is connected to the (fixed) origin of the xy -plane via an elastic rod which has a free length $L = 0.5 \text{ m}$ and elasticity constant $k = 100 \text{ N}/\text{m}$. The rod can elastically

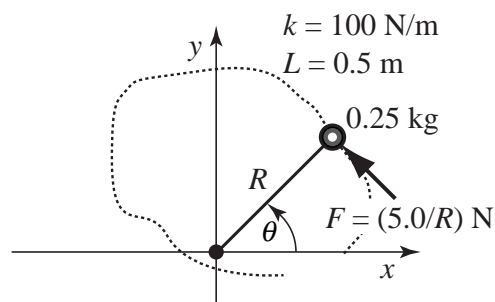

Figure 2. Material point sliding on the xy -plane while attached at the end of an elastic rod.

extend but cannot bend. The mass is acted upon by a force $F = 5.0/R \text{ N}$ oriented always in a direction perpendicular to the rod, where R is the length of the rod. From a physical viewpoint, the force F results from the application of a constant moment of magnitude $5.0 \text{ N}\cdot\text{m}$ applied to the elastic rod. At time $t = 0$, the mass is at rest with an initial position characterized by $R = 0.1 \text{ m}$ and $y = 0$.

We then ask the students to perform the following tasks:

1. Derive the equations of motion and state the corresponding initial conditions.
2. You will discover that after some time this system will be characterized by a circular motion with constant angular velocity. For convenience (and because this is how engineers refer to it), this part of the motion will be referred to as the *steady state* solution. Analytically (*i.e.*, without using computer solutions) determine the radius of the circular trajectory and the corresponding value of the angular velocity for the steady state solution.
3. Numerically integrate the equations of motion and plot the trajectory of the mass during the interval of time $0 < t < 5$ s. Verify that the trajectory will, at some point, coincide with the circle determined in Item 2.
4. Finally, repeat the operations done in Item 3 for two other sets of arbitrarily assigned initial conditions and verify that, regardless of initial conditions the motion of the mass will converge to the steady state solution. Provide a physical explanation for this behavior.

3.2 Dynamics of Particle Systems: Two Masses Connected by a Spring

This activity involves the dynamics systems of particles. In the case, the system of particles is given by two masses connected by a spring, or more accurately, an elastic rod (this is so that it can also undergo compression). The pretense for the activity is a new Olympic even in which the goal is to throw this apparatus as far as possible (see Figure 3 for a depiction of the apparatus).

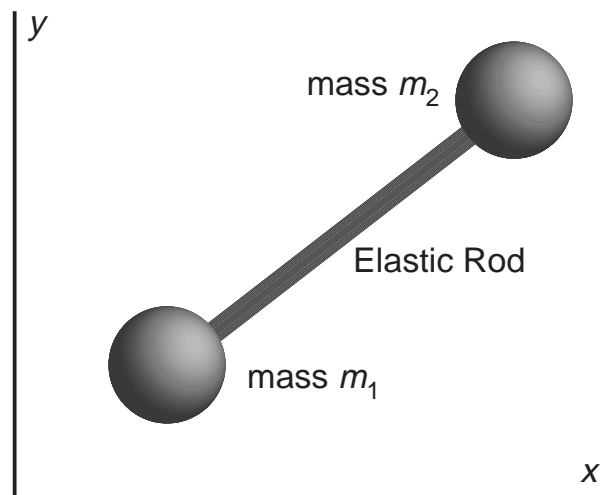

Figure 3. The pair of masses and elastic rod connecting them analyzed in the Dynamics of Particle Systems activity.

The students are provided with an unstretched length and stiffness of the elastic rod as well as the mass of each of the two masses, m_1 and m_2 . In addition, we show them a QuickTime movie, generated using Working Model, of the motion of this system over the period of interest.

In this case, we assume that the students have already been introduced to the idea of numerically solving ordinary differential equations through the use of Euler's method in Excel. Therefore, we use this activity as an excuse to introduce Mathematica (or MATLAB) as a means of solving ODEs and plotting and visualizing their solutions. Consequently, one of the first things we do is introduce the needed fundamentals of Mathematica or MATLAB. Finally, we give the students the initial positions and velocities of each mass and then ask them to do the following:

1. Plot the trajectory of each of the two masses as they fly through the air until approximately the time at which the first mass hits the ground.
2. Plot the trajectory of the center of mass of the two particles. Comment on this curve based on the theory you learn in class. That is, provide a physical explanation as to why the curves look the way they do.
3. Plot the kinetic energy, potential energy, and total energy of the system as a function of time until approximately the time at which the first mass hits the ground. Comment on these curves based on what you learn in class. That is, provide a physical explanation as to why the curves look the way they do.
4. Plot the total angular momentum of the system about the origin of the coordinate system as the particles fly through the air. Again, comment on this curve based on what the theory learned in class.
5. Set acceleration due to gravity, g , equal to zero and the plot angular momentum as you did in Step 4. Again, comment on this curve based on the theory learned in class. That is, provide a physical explanation as to why the curves look the way they do.

We have found that either Mathematica or MATLAB provide a simple and effective way to elucidate the dynamics of particle systems. In addition, this activity allows us to once again talk about design and optimization. In this case, we do so by asking students to play some "what if" games with the initial positions and velocities of the two masses and how they affect the distance traveled by the system.

3.3 Experimental Determination of the Acceleration Due to Gravity

Usually, the first activity of the semester is one where all the student teams experimentally determine the acceleration due to gravity, g .

3.3.1 The Experimental Part

We begin by introducing the equation of motions governing the motion of an ideal pendulum. In this case we have not yet covered curvilinear coordinates, so we derive the equations in Cartesian coordinates, thus yielding two equations of motion. We then show the students how the resulting two equations can be converted to a single equation of motion in polar coordinates. Following this, we show the students what form can be given to the equation of motion for small oscillations via the approximation $\sin \theta \approx \theta$. We then proceed to introduce enough vibration theory so that the students have the ability to extract the period of oscillation from the linearized equation.

This allows us to show them that the important parameters in measuring the acceleration due to gravity, at least as far as theory tells us, are the length and period of the pendulum. We then head out to an area that has overhanging balconies so that we can create pendulums with very long lengths (*i.e.*, approximately 15–20 feet).

We then ask the students to come up with an experimental procedure for measuring g . We tell them that we want them to measure g as accurately as possible (by measuring the period and length of the pendulum) and to try and ascertain all the possible sources of error in their procedure. Once they have determined a value for g , we ask them to speculate on why the value they have obtained differs from the value they have been told to use ever since high school.

3.3.2 The Analytical Part

Having done the experimental part of the activity, we then ask the students to use Excel, Mathematica, or MATLAB (depending on what we have introduced or what we want to introduce at this point) to integrate the nonlinear equation of motion to find the period of their pendulum for the swing angle used in the experimental part of the activity. This gives them their first opportunity to numerically solve equations of motion in addition to giving them the opportunity to compare “theory” and “experiment”.

3.4 Elastic Particle Impact and A Ballistic Pendulum

This activity focuses on particle impact, both plastic and elastic, through two largely unrelated sub-activities.

3.4.1 Elastic Impact of Spheres

In this part of the activity their goal is to be able to predict the rebound height of the top ball in a stack of three balls (see Figure 4). The students begin by measuring the coefficient of restitution

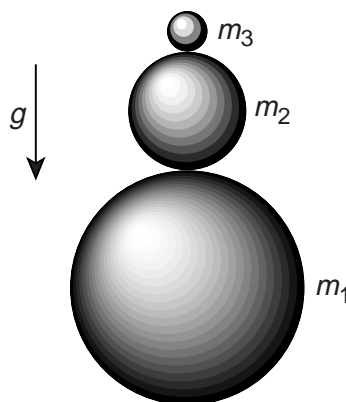

Figure 4. The three balls, along with their labeling scheme, used in the elastic impact activity. We typically use basketballs, rubber “superballs”, and the “playballs” that can be found in any discount store (*e.g.*, Wal-Mart).

of each of the balls to be used in the experiment. We ask them how they might do this and give them the hint that the height of rebound of a ball off of a fixed surface depends on the coefficient of restitution. We tell them to try dropping the same ball from the same height onto different surfaces (*e.g.*, carpet, table, toes, etc.) to see how the rebound height differs with each surface. Having measured the appropriate coefficients of restitution, they then measure the mass of each ball using the scale provided.

Having done all of this, we then ask them to perform the following calculations:

1. Assume that you have stacked two balls m_1 and m_2 , that m_2 is on top of m_1 , that the mass of $m_2 \ll m_1$, that all impacts are perfectly elastic ($e = 1$), and that they are dropped from a height h . Compute the rebound height of mass m_2 as a function of h .
2. Now do exactly the same thing, except use three balls of mass m_1 , m_2 , and m_3 and assume that $m_3 \ll m_2 \ll m_1$. In this case, compute the rebound height of m_3 .
3. Having done the previous two calculations, can you generalize to what the rebound height of n balls should be?
4. Use what you have learned in the previous calculations to predict the rebound height of two, then three, of the stacked balls for which you have measured e and m .

Finally, actually do the experiment for which you have predicted the results in Step 4 above. That is, stack two balls, drop them from a known height h , and measure the rebound height of m_2 . Then, if possible, stack three balls, drop them from a known height h , and measure the rebound height of m_3 .

3.4.2 A Ballistic Pendulum

The second part of the experiment involves the study of plastic impact through the analysis of a ballistic pendulum. This is a classic problem for which we have videotaped a bullet being fired into a block of wood suspended from a pivoted rigid rod (see Figure 5). We tell the students that

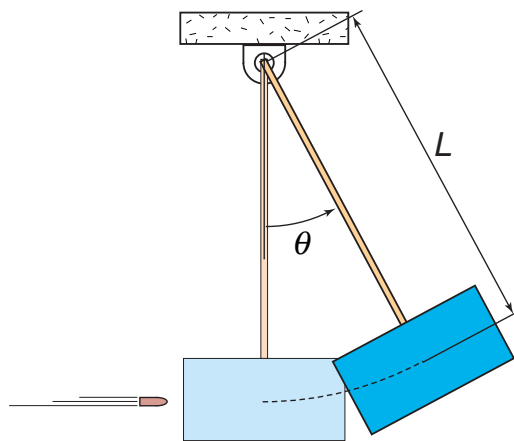

Figure 5. The ballistic pendulum. The block at the bottom is a 12-inch long 4×4 and the rod is a 1/2-inch wooden dowel. The pivot at the top is a simple hinge.

in this activity they will analyze a movie displaying the motion of a (ballistic) pendulum being hit by a bullet fired by a rifle. The analysis is done using VideoPoint, a software package that allows them to measure spatial and temporal two-dimensional data of the motion of one or more objects from a QuickTime movie. Their task is to measure the velocity of the bullet as it enters the block and to compute the percentage of energy lost during the impact.

As part of the activity, we have them measure what they feel are the appropriate properties of the pendulum. At this point in the semester, we have not yet covered any rigid body dynamics, so many of the students do not know to take into account rotational inertia. The only thing we provide them is the mass of the bullet. As a point of comparison, when all the students are done with the analysis, we provide them with the bullet velocity measured using an electromagnetic device used at the time of videotaping. Interestingly, and very fortuitously, the students are usually within 5% of the velocity measured by a very expensive piece of instrumentation.

3.5 Kinematic and Kinetic Analysis an Automotive Slider-Crank

This activity is a rather large two-part activity in which the students play the role of an automotive engineer. In this activity, they perform a complete kinematic and kinetic analysis of part of the innards of a piston engine. Their eventual goal is to:

1. find acceleration curves for the important parts of the crank, connecting rod, and piston within the engine;
2. find the forces at critical locations within this same system;
3. understand some of the reasons why engines are designed the way they are.

As part of the introduction to this activity we explain the layout of an internal combustion engine, give the students some idea of how it works, and show then exactly where one would find the crankshaft, connecting rod, and piston in an internal combustion engine.

3.5.1 Kinematic Analysis

The students begin by doing a kinematic analysis of the slider-crank (*i.e.*, crank, connecting rod, and piston) mechanism depicted in Figure 6. We provide them with all the necessary geometric properties to do the analysis. We tell them to assume that the engine starts out at $\theta = 0$ and that the speed of the engine (and thus $\dot{\theta} = \omega$, the angular speed of the crank) is given by $\omega = \omega_0(1 - e^{-3t})$. We then ask them to find and plot the following kinematic quantities as functions of time t (assuming $\omega_0 = 3000$ rpm):

1. The acceleration of point D , the mass center of the connecting rod.
2. The angular acceleration of the connecting rod.
3. The acceleration of the piston.

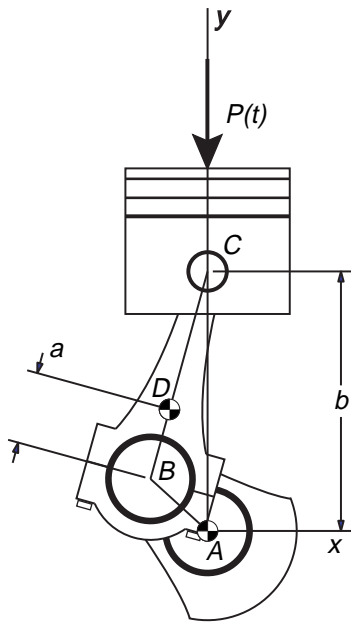

Figure 6. Schematic of the slider-crank mechanism to be analyzed.

After completing the above kinematic analysis, we then ask the students to find those positions that are “limiting positions” of the slider-crank mechanism. That is, after the system appears to reach a steady state, what are those crank angles that give the highest linear and angular accelerations of each of the components (really just the connecting rod and the piston). We then ask the students why do they might want and/or need to find these locations?

3.5.2 Kinetic Analysis

Now that they have done the entire kinematic analysis and have been given the necessary mass properties, we ask them to go ahead and find the following forces acting on the system (not necessarily in any particular order):

- The total force on the pin (B) connecting the crank to the connecting rod (as a function of time).
- The angle of the force on the pin at B relative to the orientation of the connecting rod (as a function of time).
- The total force on the pin (C) connecting the connecting rod to the piston (as a function of time).
- The angle of the force on the pin at C relative to the orientation of the connecting rod (as a function of time).
- The output torque delivered to the crank/crankshaft (again, as a function of time).

We then ask them to find the maximum value attained by each of these forces. They do this by using Mathematica to plot all of the forces/torques and angles they found above as a function of time.

We tell the students that the force P on the top of the piston is assumed to be known. We will model P as a piecewise constant force that is equal to 3000 N for θ between 0 and π (the explosion part) and is equal to 750 for θ between π and 2π (the part of the cycle during which exhaust gases are ejected). At 2π , the force simply repeats. We tell the students that a piecewise continuous force such as this one can be difficult to deal with computationally so therefore we introduce a new concept by telling that we will use the first four non-zero terms in the Fourier series representation for P as given in the following equation

$$P(\theta) \approx 1875 + \frac{1}{\pi}(4500\sin\theta + 1500\sin 3\theta + 900\sin 5\theta).$$

We ask the students to comment on the following items:

- Compare the maximum acceleration of the piston with the acceleration of gravity and with your estimate of the maximum acceleration of a fast automobile. In addition, compare it with the maximum number of “g’s” that a human can withstand.
- Looking at your plot of output torque versus time and given that we are assuming that the crank rotates at a constant angular velocity when in steady state, why is the output torque not constant? In addition, what features might you add to the engine so that you obtain a nearly constant output torque for a constant angular velocity of the crank?
- What is the area under your output torque versus time curve for one complete cycle of the crank? Use that area and the time it takes for one rotation of the crank to compute the horsepower of your engine. Finally, compare the horsepower of your engine with that of the 3 engines of the Titanic (you will find this on the web if you look hard). What is the horsepower of a typical automobile engine?
- How does the maximum total force on each of the pins compare with the weight of a typical person?

4 Conclusion

We have tried to give a representative sampling of some of the activities used in Interactive Dynamics at Penn State University. We hope that these not only give a flavor of what our new course is like, but also give you some ideas and material that you can use in your dynamics course, even if it is not Interactive.

Acknowledgments

We would like to thank the Penn State College of Engineering and the Department of Engineering Science and Mechanics for providing course enhancement funds and to acknowledge receipt of a grant from the General Electric Fund in support of the Interactive Classroom concept.

References

- [1] *ABET Engineering Criteria 2000, Third Edition* (1997). Available at the following WWW site: <http://www.abet.org/eac/eac2000.htm>.
- [2] *ABET Mechanical Engineering & Engineering Mechanics Criteria 2000* (1998). Available at the WWW site: <http://www.asme.org/educate/abet/progcrit.htm>.
- [3] *ABET 2000 Program Criteria: Materials and Metallurgy* (1998). Available at the following WWW site: <http://www.tms.org/Education/ABET2000.html>.
- [4] M.S. Wald, "Engineering Criteria 2000," *International Journal of Engineering Education*, **12**, pp. 389–390 (1996).
- [5] Gary L. Gray and Francesco Costanzo, "On the Concept of the Interactive Classroom and its Integration into the Mechanics Curriculum," To appear in the *International Journal of Engineering Education*.
- [6] Francesco Costanzo and Gary L. Gray, "On the Implementation of Interactive Dynamics," To appear in the *International Journal of Engineering Education*.
- [7] Gary L. Gray and Francesco Costanzo, "Interactive Dynamics: A Collaborative Approach to Learning Undergraduate Dynamics," *1999 ASEE Annual Conference and Exposition*, Charlotte, North Carolina, June 20–23.
- [8] Patricia M. Yaeger, Rose M. Marra, Gary L. Gray, Francesco Costanzo, "Assessing New Ways of Teaching Dynamics: An Ongoing Program to Improve Teaching, Learning, and Assessment," *1999 ASEE Annual Conference and Exposition*, Charlotte, North Carolina, June 20–23.

GARY L. GRAY

Gary earned a Ph.D. in Engineering Mechanics in 1993 from the University of Wisconsin–Madison. Prior to that, he received an M.S. in Engineering Mechanics from the University of Wisconsin–Madison, an S.M. degree in Engineering Science from Harvard University, and a B.S. in Mechanical Engineering from Washington University. He is currently an Assistant Professor of Engineering Science and Mechanics at Penn State University, where his research has focused on nonlinear dynamics and chaos in engineering systems. Since arriving at Penn State, he has used his background in mechanics to begin investigating the use of shape memory alloys in electrical connectors. He teaches courses in dynamics, nonlinear dynamics, vibrations, and numerical analysis and is actively involved in the reform of undergraduate mechanics education.

FRANCESCO COSTANZO

Francesco is currently an Assistant Professor of Engineering Science and Mechanics at Penn State University. He joined the faculty of the Engineering Science and Mechanics Department in the fall of 1995. Prior to this he held a position as a Lecturer and Post-Doctoral Scholar with the Mathematics Department at Texas A&M. He came to the U.S. in 1989 from his home country of Italy following a B.S. degree (magna cum laude) in Aeronautical Engineering from the Politecnico di Milano (Milan, Italy, 1989) on a Fulbright Scholarship. He obtained his Ph.D. degree in Aerospace Engineering from Texas A&M University (College Station, TX) in 1993. His professional interests include fracture mechanics of nonlinear history dependent materials, homogenization of composites with evolving microstructure, linear and nonlinear computational mechanics, continuum thermodynamics of phase transition, and evolving interfaces.