

## **Development of an Instructor Station for Electrical Engineering Laboratories**

**Richard L. Martin, Michael G. Morrow, and Thad B. Welch  
United States Naval Academy**

### **Abstract**

An individually laboratory-based Centralized Signal Distribution System has been developed to provide known signals in labs for undergraduate core electrical engineering and technology courses. The system consists of a general purpose PC running LABVIEW software which controls three Arbitrary Waveform Generators. LABVIEW, a graphical programming language, allows easy programming of the instruments. The source code for LABVIEW looks like a flowchart, while the user interface appears on the monitor as the front panel of a virtual instrument. The presently developed system is programmed to provide basic signals for introduction to signal waveform analysis and oscilloscope operation, phase-locked waveforms of integrally related frequencies for digital applications, AM and FM signals for elementary communications experiments, and frequency sweeps for testing of analog transfer functions. Signal parameters such as DC offset, frequency, phase, amplitude, waveform, and modulation may be readily changed by the lab instructor.

## I. Introduction

In the teaching of introductory or core courses in electrical engineering or technology, laboratory experience by the students is a necessity. In teaching basic signal analysis and/or introductory communications theory and the use of basic instrumentation, it has been found that provision of known signals to the various student laboratory stations both increases the efficiency of the instructor's time and enhances the student's learning. For over thirty years, the Electrical Engineering Department at the U. S. Naval Academy has used a central signal distribution system in its laboratories. The system was installed in 1968 and has been used to the present. The EE laboratory complex was in fact constructed around that facility, and the majority of the EE labs have been tied to that facility.

For core labs as well as introductory majors' labs, the system has been used to generate signals with known amplitude, frequency, phase, and waveshape used in the EE laboratories. These signals range from simple sine waves with DC offsets for teaching use of the oscilloscope, to more complex digital waveforms and AM and FM signals for communications experiments. Each signal is generated from a signal generator in the Central Signal Facility and distributed to each of the student lab stations in the particular laboratories which use that signal. Some signal generation requires the use of amplifiers and/or specially constructed circuit cards to modify or combine simple signals before distribution. Signals with fixed phase differences are provided by generating a reference signal, passing that signal through a phase shifting network, and then distributing both signals. The pattern of signals for a laboratory is specified by the course coordinator, set up by a technician, generally at the beginning of the week, and is maintained through the week.

This paper describes the development and implementation of a microcomputer based instructor station which provides the previously described signals, can be installed in individual laboratories, and can be "programmed" by individual instructors to either a default set of signals or to a temporary alternative set of signals for individualized demonstrations or quizzes. The settings may also be readily stored and retrieved for later use.

## II. Equipment Utilized

A single instructor station has been set up and is currently being used in Michelson Lab E1, for use in EE311 (Fall 1999) and EE312 (Spring 2000). The microcomputer based instructor station makes maximum use of the existing laboratory bench equipment and interconnecting cabling. The previous cabling, which had been run from the Central Signal Facility in Michelson E5 to the lab through cable ducts in the floor, was terminated in the lab. The cabling changes and the resulting configuration with the instructor station are shown in Figure 1.

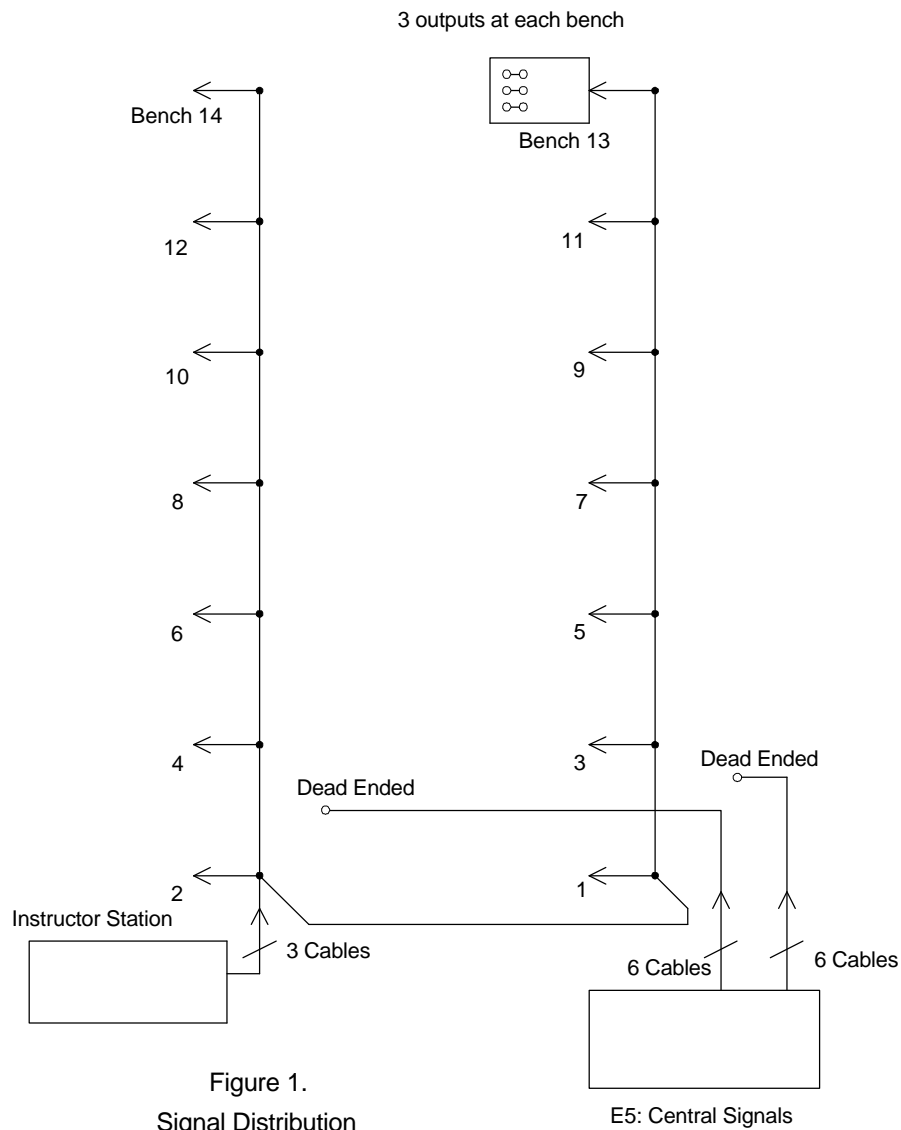

### III. Instructor Station

The instructor station consists of a general purpose personal computer running LabVIEW (Laboratory Virtual Instrument Engineering Workbench) software from National Instruments, which controls three arbitrary waveform generators (AWGs) as shown in Figure 2. The AWGs chosen were Hewlett Packard model 33120A AWGs, each retailing for \$2200, equipped with a Phase Lock Loop (PLL) option.

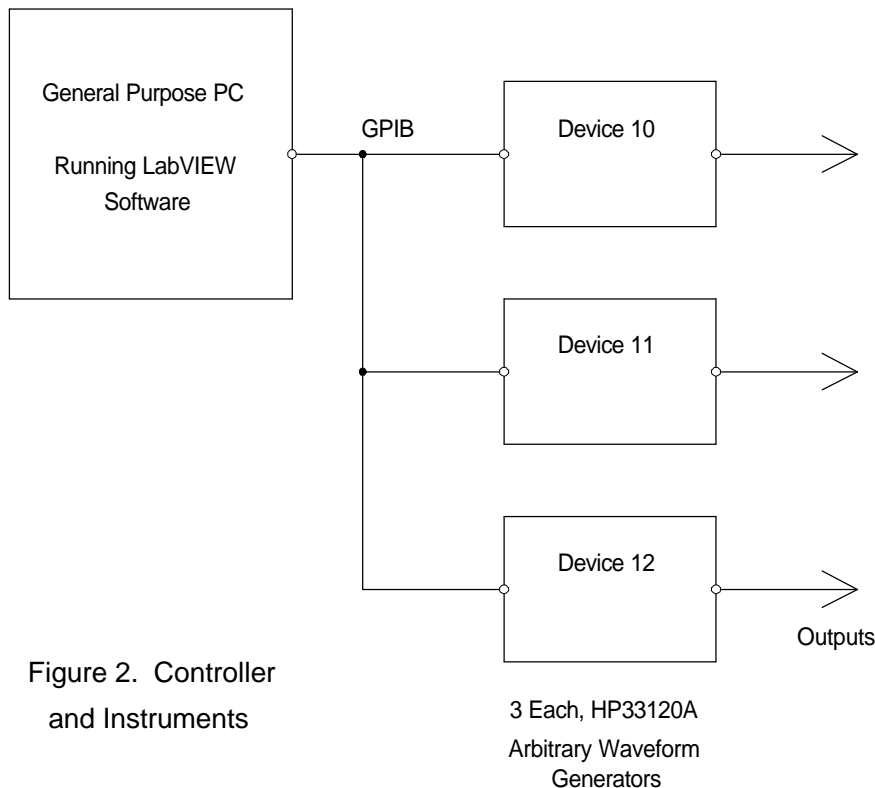

Figure 2. Controller and Instruments

The HP 33120A AWGs can provide sinusoidal and square wave frequencies up to 15 MHz, triangle and ramp frequencies up to 100 KHz, and arbitrary waveforms using up to 16,000 points, using a sampling rate of 40 Msamples/second, with 12 bit resolution. Modulation capabilities include internal AM, FM, and FSK, along with external sources for AM and FSK. GPIB and RS-232 interfaces are also included, and the generators are controlled either manually or by commands in compliance with the Standard Commands for Programmable Instrumentation (SCPI). Each AWG has a 50 Ohm output impedance and provides signals up to  $\pm 5$  Volts (peak ac + dc) into a 50 Ohm load, or up to  $\pm 10$  Volts into a high impedance load. A diagram of the external connections required between the AWGs to phase lock the various signals is shown in

Figure 3.

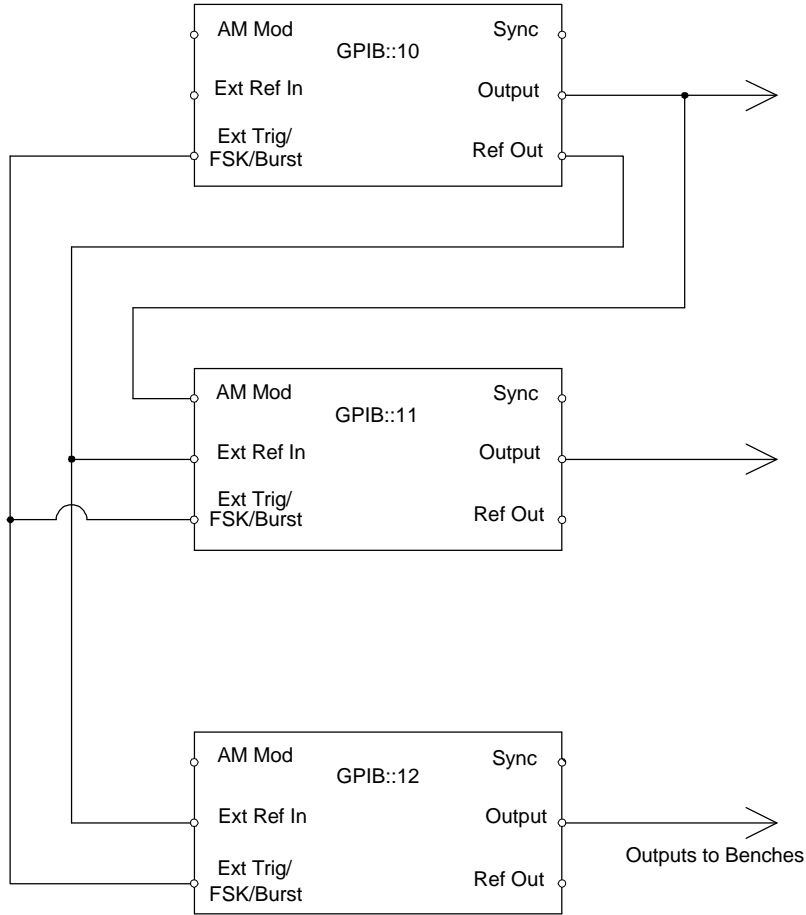

Figure 3.  
External Connections  
for Generators

Although the generators may be controlled by HP “BenchLink Arb” software, a graphical user interface was determined to be necessary for wider use by faculty with minimal training required. LabVIEW software was found to provide an ideal interface. LabVIEW is itself a graphical programming language where the user interface appears as the front panel of a virtual instrument, and the source code looks like a flow chart. Each node of the flow chart executes a particular function such as selecting a waveform, frequency, or amplitude. Wires in the block diagram connect nodes together, and the execution order of the program is established by data flowing from one node to another.

LabVIEW communicates with and controls external instruments (such as generators, oscilloscopes, and multimeters) using the GPIB as well as other interface bus standards. The LabVIEW “Instrument Wizard” software allows the programmer to automatically detect connected instruments, install the required instrument drivers, and manage the instrument drivers

already installed. An instrument driver is a piece of software (that is, a Virtual Instrument) that controls a particular instrument. The instrument driver for the HP 33120A AWG is included in LabVIEW's virtual instrument library.

## IV. Operation of the Central Signal Instructor Station

The Central Signal Instructor Station allows the user to control the signal generator settings, save settings to disk, and to load settings from disk. All user interaction occurs through the virtual control panel depicted in Figure 4. Operating instructions, along with six suites of signals have been developed for use in the laboratories for EE311 (Fall 1999) and EE312 (Spring 2000), Electrical Fundamentals and Applications I and II, taught to junior level students majoring in Math and Science.

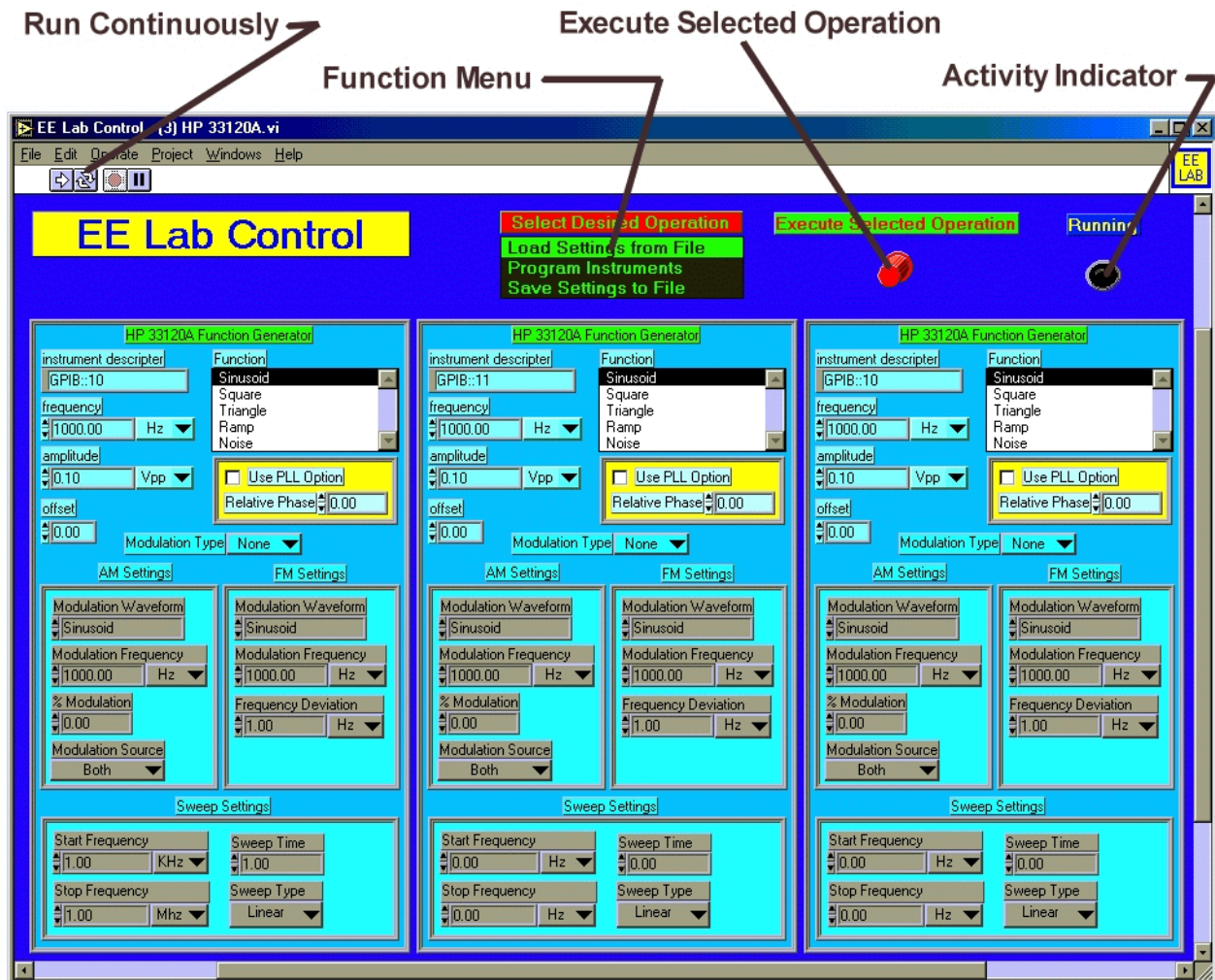

Figure 4. Instructor Station Virtual Control Panel

## Activating the System

Turn the computer ON. Turn on the HP33120A Arbitrary Waveform Generators.

On the computer, double-click the “*EE Lab Control*” icon.

A menu will appear listing the available Virtual Instrument (VI) files.

Double-click the menu item “*EE Lab Control - (3) HP33120A.vi*”

A virtual control panel with three signal generator panels should appear.

Click the “*Run Continuously*” button at the upper left of the virtual control panel.

The activity indicator in the upper right of the virtual control panel will blink, indicating the program is running.

## Loading Previously Saved Settings

Click on “*LOAD SETTINGS FROM FILE*” in the function menu of the virtual control panel.

Click the “*EXECUTE SELECTED OPERATION*” button.

Select the desired file from the menu by opening that file.

The settings for frequency, amplitude, offset, and phase will appear on the various generator panels.

Click on “*PROGRAM INSTRUMENTS*” in the function menu of the virtual control panel.

Click the “*EXECUTE SELECTED OPERATION*” button.

The displayed settings will be downloaded to the generators. The generator displays will indicate each generators instrument descriptor. Any errors in the process will be displayed as pop-up windows on the computer.

## Modifying Instrument Settings

Make the desired changes to the instrument setting by directly editing them on the virtual control panel.

Click on “*PROGRAM INSTRUMENTS*” in the function menu of the virtual control panel.

Click the “*EXECUTE SELECTED OPERATION*” button.

The displayed settings will be downloaded to the generators. The generator displays will indicate each generators instrument descriptor. Any errors in the process will be displayed as pop-up windows on the computer.



## **Saving Current Settings**

Click on “*SAVE SETTINGS TO FILE*” in the function menu of the virtual control panel.

Click the “*EXECUTE SELECTED OPERATION*” button. Select the desired file to write the settings to.

The displayed settings will be written to the selected file.

## **Shutting Down the System**

Close the virtual control panel, and exit the LabView dialog box.

Perform a normal shutdown on the computer.

Turn off the computer and the HP33120A Generators.

## V. Descriptions of Signal Distribution and Signal Suites

The signals generated by the AWGs are distributed by coaxial cables to each student station through a signal panel and its accompanying high input impedance isolation amplifiers as shown in Figure 5. A one KiloOhm resistance is connected inside the panel in series with each line at the student station to prevent any short circuiting of the signal at any bench from affecting the signal at any other bench. Although the original panel was designed to accept six different signals, no more than three different signals have been required at any one time.

Six suites of signals are presently stored as files on the PC. Their file names with brief descriptions and usages are as follows. Since the first two listed are the most widely used, more extensive descriptions are provided along with associated connections, circuitry, and displays of the waveforms from a digitizing oscilloscope set up at the Instructor Station.

### 1. DC\_FREQ\_PH\_1:

This provides three phase-locked sinusoids (shown in Figure 6) with dc offsets and phase shifts. This suite of signals has been used in an existing lab concerned with teaching electronic signal fundamentals and oscilloscope operation. This is one of the most important laboratory experiences for our students who are not in an ABET accredited program and do not consider themselves to be engineers, but who still need the fundamentals of signal analysis. In addition to a general technical competency requirement, professional competency also requires understanding of three phase power distribution, which is a subset of this signal suite. The suite of signals is normally set up with the signal from Device 10 (signal 1 at the student station) as the reference. The signal from Device 11 may be used as a demo to lead the student through the process of measuring DC offset, amplitude, and phase. Then the signal from Device 12 is used as an exercise where help in performing the measurements may be obtained. Later, the complete suite of signals may be readily changed (in less than 30 seconds) and used as a graded quiz.

The instrument settings for this suite of signals are presently as follows.

	Instrument 1	Instrument 2	Instrument 3
Instrument Descriptor	GPIB::10	GPIB::11	GPIB::12
Frequency	1250.00 Hz	1250.00 Hz	1250.00 Hz
Function	Sinusoid	Sinusoid	Sinusoid
Amplitude	8.00 V p-p	4.00 V p-p	2.00 V p-p
Use PLL Option	ON	ON	ON
Relative Phase	0.00 (degrees) (the reference)	60.00 (degrees) (phase lead)	-125.00 (degrees) (Phase lag)
Offset	3.00 (Volts)	-5.00 (Volts)	4.00 (Volts)
Modulation Type	None	None	None

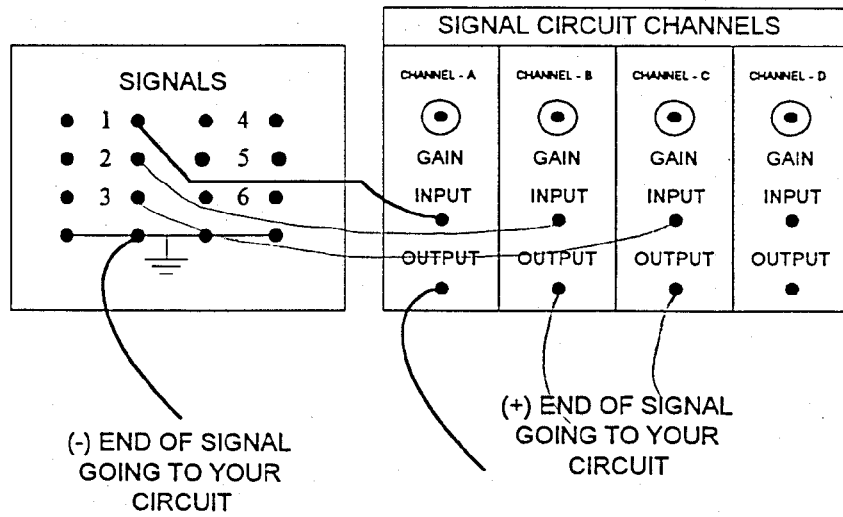

Figure 5. Student Station Panel

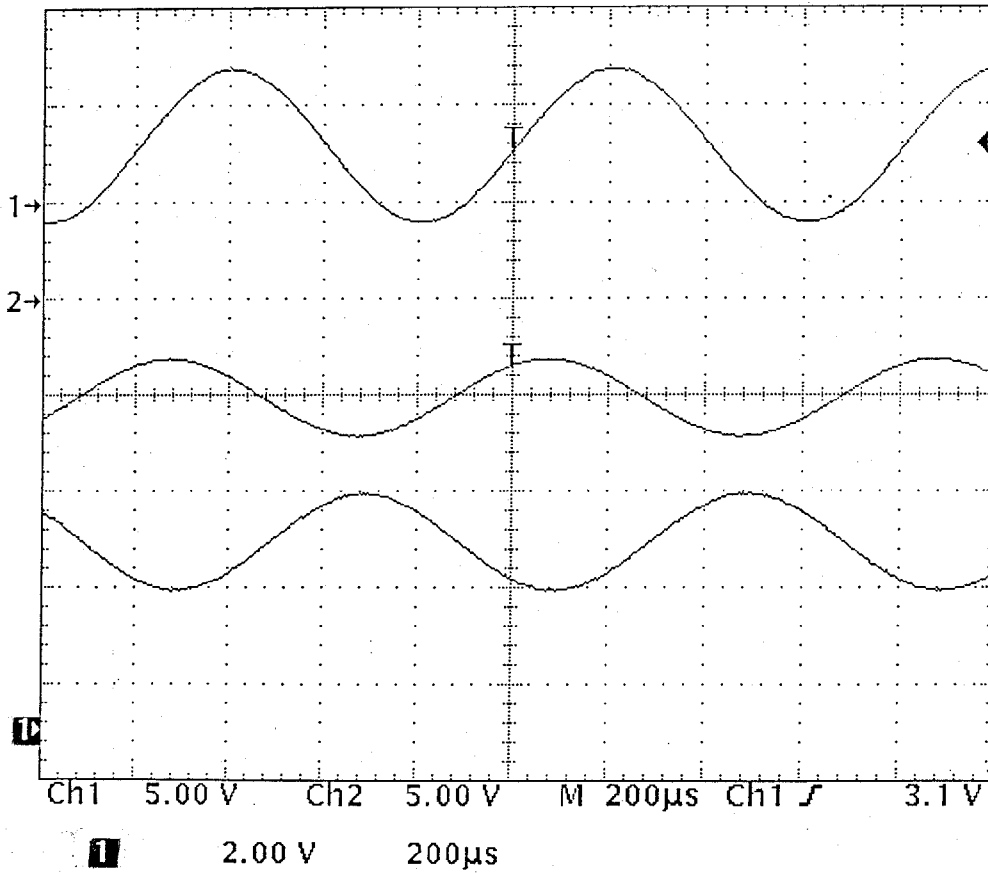

Figure 6. Three Phase-Locked Signals

2. AM\_20\_1\_80PC:

The AM signal is used in a lab covering fundamentals of communication systems, modulation, and demodulation circuitry where the performance of a simple demodulator circuit (Figure 7) is studied. The greatest additional advantage here is that an AM modulated sinusoid (Figure 8) is provided where the carrier and modulation are phase locked. The previously used AM signal did not have the carrier and modulation locked together, resulting in a smeared presentation of the carrier on the oscilloscope. Now the effects of changing the demodulator time constant can be readily observed, and the students' tendency to "press the 'I believe' button" is greatly reduced.

The instrument settings for this suite of signals are presently as shown below. Instrument 1 provides a phase-locked reference for triggering an oscilloscope for monitoring the AM signal as well as the external modulation source for Instrument 2. This reference may or may not be distributed to the student station. Once the AM signal is demodulated, the result may be used to trigger the oscilloscopes at the student stations. Note that nothing is specified in the Modulation Source blocks for Instruments 1 and 3 since no modulation type is specified for those instruments. Although Instrument 3 is not used, it may have extraneous settings assigned to it, such as from a previous lab. The ability to generate phase-locked signals at integrally related frequencies, as between Instruments 1 and 3, allows for interesting oscilloscope displays which entertain both students and other faculty.

	Instrument 1	Instrument 2	Instrument 3
Instrument Descriptor	GPIB::10	GPIB::11	GPIB::12
Frequency	1000.00 Hz	20000.00 Hz	1250.00 Hz
Function	Sinusoid	Sinusoid	Sinusoid
Amplitude	8.00 V p-p	9.00 V p-p	2.00 V p-p
Use PLL Option	ON	OFF	ON
Relative Phase	0.00 (degrees) (the reference)	0.00 (degrees)	-125.00 (degrees)
Offset	0.00 (Volts)	0.00 (Volts)	4.00 (Volts)
Modulation Type	None	AM	None
Modulation Source	---	Ext	---

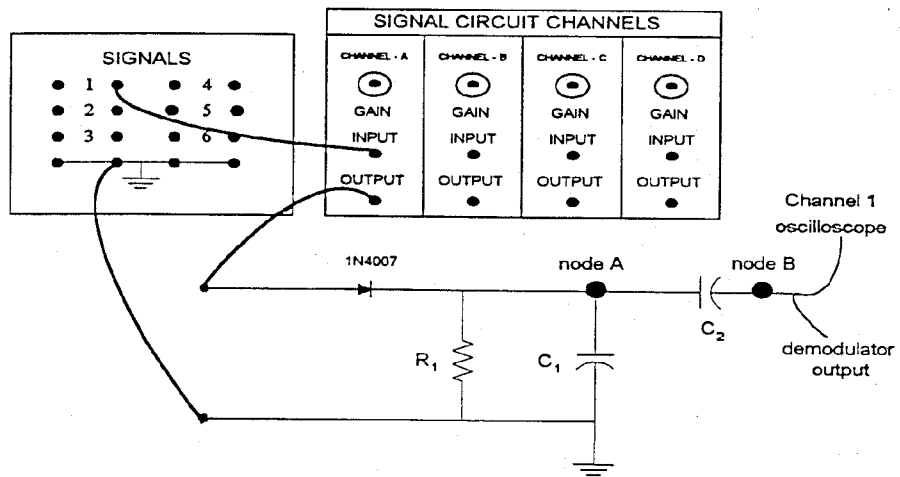

Figure 7. Simple Demodulator Circuit

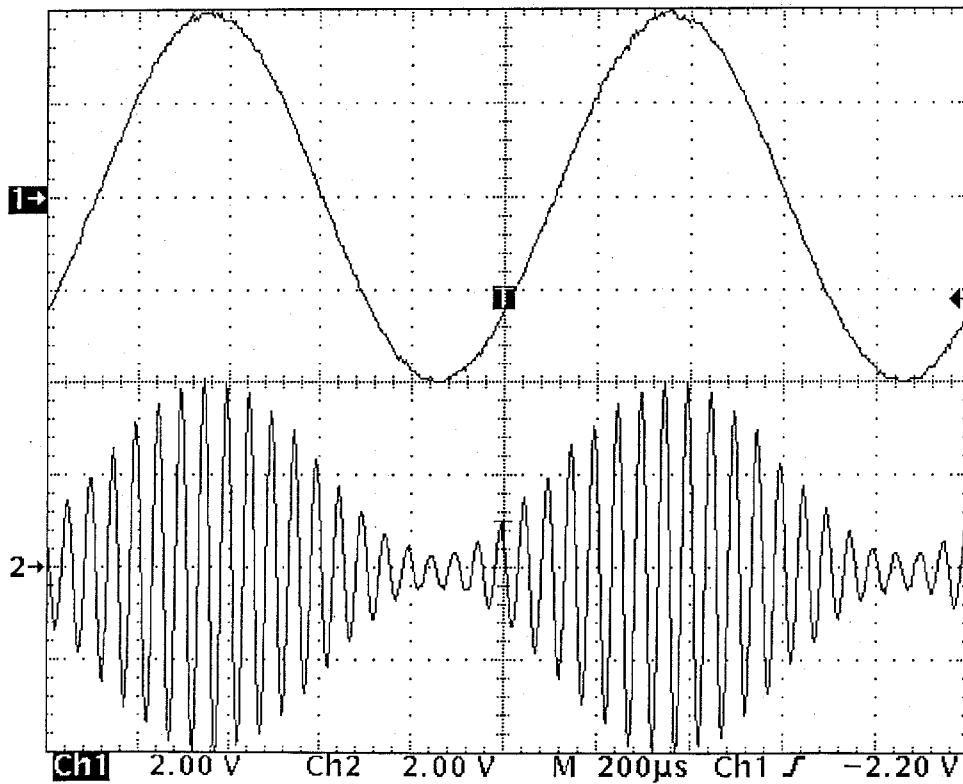

Figure 8. Amplitude Modulated Waveform

3. FM5\_1\_2:

An FM modulated sinusoid is generated where the carrier and modulation are phase locked. The stability of the waveform is a capability which we did not have previously. This setup may be used to show various FM waveforms and allows us to reintroduce basic FM circuitry operation either as demonstrations or actual lab exercises. Labs run previously suffered from the inability for the affected signals to be clearly observed, and the lab exercises fell into disuse.

4. SQUARES1\_2\_4:

Here, three phase-locked square waves at frequencies in the ratios of 1 // 2 // 4 are provided. These waveforms are used in an existing digital circuits lab concerned with counters and digital-to-analog conversion.

5. SQLAGS1\_2\_4:

These waveforms are similar to those provided by SQUARES1\_2\_4, but with intentionally introduced lags between the waveforms. They can be used to demonstrate the effects of delays and signal race conditions in unlocked digital systems.

6. SWEEP2\_10KHZ:

This provides a fixed amplitude signal whose frequency is swept linearly from one frequency to another. This signal may be used to readily show the characteristics of filters, particularly narrow bandpass types. Previously used lab exercises were deleted due to the difficulty of maintaining the stability of the swept signals.

## VI. Summary

The individual laboratory-based Instructor Station and Signal Distribution System presented here has been a complete success. The system, consisting of a general purpose PC running LabVIEW software which controls three Arbitrary Waveform Generators (AWGs), allows for rapid lab equipment setup without the loss of flexibility associated with a centralized distribution facility.

Instructor reaction has been quite favorable. Particularly noted is that the graphical user interface, appearing on the monitor as the front panels of three virtual instruments representing the three AWGs, provides a simplistic method for setting up the required suite of signals. Selection of the desired signals by simply pointing and clicking has been found to be more intuitive than pushing buttons and turning dials to accomplish the same action. Generating well defined and stable phase separations previously was particularly difficult. A record of the signal settings can be readily printed from the computer, and rechecking of the signals during the lab time is not necessary. Another clearly perceived advantage is the ability to save a particular setup to a file and then recall the settings when needed for other lab times or make-up lab sessions.

## References

1. Robert H. Bishop, *Learning with LabVIEW*, Addison-Wesley, 1998.
2. User's Guide, *HP 33120A Function Generator / Arbitrary Waveform Generator*, Hewlett-Packard, Edition 5, 1997.
3. User's and Service Guide, *HP 33120A/Option 001, Phase-Lock Assembly*, Hewlett-Packard, Edition 1, 1994.

### RICHARD MARTIN

Professor Richard L. Martin is Associate Chair of the Department of Electrical Engineering at the United States Naval Academy. He teaches the EE majors' senior design course and laboratory sequence and coordinates the senior design projects. He received his PhD from the University of Maryland, College Park, in 1968. Dr. Martin is a registered Professional Engineer in the State of Maryland and has been actively involved in research with the Naval Research Laboratory (Washington, D. C.) and the Naval Surface Warfare Center (Annapolis).

Email: [rmartin@nadm.navy.mil](mailto:rmartin@nadm.navy.mil)

### MIKE MORROW

Lieutenant Commander Michael G. Morrow, PE, is a Master Instructor in the Department of Electrical Engineering at the U.S. Naval Academy. His research interests include real-time digital systems, power system automation, and software engineering. He is a member of IEEE and ASEE. Email: [morrow@ieee.org](mailto:morrow@ieee.org)

### THAD WELCH

Commander Thad B. Welch, PhD, PE, is an Assistant Professor in the Department of Electrical Engineering at the U. S. Naval Academy. From 1994 - 1997 he was an Assistant Professor in the Department of Electrical Engineering at the U. S. Air Force Academy. His research interests include multicarrier communication system design and analysis, RF channel measurements, and real-time signal processing. He is a member of ASEE and Eta Kappa Nu and a senior member of the IEEE. Email: [t.b.welch@ieee.org](mailto:t.b.welch@ieee.org)