

# Electromagnetic Aircraft Launching Unit (EMALU)

Rahmi Allamadani  
CETA University of Hartford  
Hartford, United States  
Allamadan@hartford.edu

Feng Chen  
CETA University of Hartford  
Hartford, United States  
Chen@hartford.edu

**Abstract**— The concept of using electromagnetic forces to launch an object has been discussed and researched by numerous engineers for decades now, only recently has it become more realizable with advances in technology. The goal of this project is to use electromagnetic forces to propel a payload down a track at a desired velocity for launch. An electromagnetic launch system is one that harnesses the power of using a large electric current to generate a magnetic field which can push a magnetized cylinder down a channel for launch. Research on electric catapult systems have been around since 1940's including some done by the United States Navy however, because of the limitations of energy storage at the time the project had been abandoned. For this application the goal will be to propel a large mass such as the aircraft in a linear motion to a high enough speed where it can be launched from a short runway.

## I. INTRODUCTION (Heading 1)

The current system in place right now by the US Navy uses a steam powered system that pushes two pistons the length of the runway by highly pressurized steam. Some of the disadvantages of this system include the size and weight limitations that the catapult can actually propel. In addition, steam powered catapults impart large transient loads to the airframe and are difficult to maintain. Furthermore, the amount of weight the current catapults are capable of launching limits the types of planes that are compatible with it. The advantages to using electromagnetic catapults are much greater than current systems in place it will be the goals of this project to further explore these possibilities. The steam powered system can launch a 45,000 pound plane from 0 to 165 mph in only two seconds under the distance of 100 yards. Our goal will be to modify the same design for an electromagnetic launch and receive similar speeds on a smaller scale instead.

## II. EASE OF USE

### A. Selecting a Template (Heading 2)

For the design that is being used for this project contains a rectifying circuit for charging of the capacitors. The capacitors that are being used in this application are two 250V 12,000 $\mu$ F which are not capable of being fully charged by a regular power supply. In order to fully charge the capacitors the charging circuit will contain several voltage doublers to give enough voltage to charge the capacitors. Once the capacitors are charged they amount of charge will be monitored in LabView by using a voltage divider and scaling the low

voltage in LabView appropriately to give an accurate reading. The amount of charge stored in the caps will vary depending on the amount of weight that is trying to be launched. Attached in between the capacitors and coil is a 4 layered PNP SCR (Silicon Controlled Rectifier) which is triggered by a lower voltage of 1.7V. When the lower voltage is applied at the gate of the SCR the current from the capacitors passes through the PNP junction and flows through the coil. When current is flowing through the coil it generates a magnetic field around the piston that has an opposing magnetic charge of the coil repelling it through the channel at very high speeds. Several switches are used in the circuit for safety including a charging switch and firing switch. The control system for this project will all be done through LabView which will apply the 1.7V to gate of the SCR to trigger the device. In addition to triggering the SCR, LabView will also be responsible for determining how much charge the capacitors will hold depending on how much weight is being launched by thresholds set in the program.

## III. THE CHALLENGE

The challenge of this project will be to get the projectile up to a fast enough speed in a short distance. Using a coil gun for this type of application can improve the current design of steam catapults for several reasons. For example, by increasing the amount of current in the coil at the end of the track the speed of the launch will be proportionally increased. In addition, this design will reduce the amount of stress on the frame the aircraft carrier. Currently the United States Navy is working on a similar idea called the Electromagnetic Aircraft Launch System or EMALS which uses a similar concept. For this project we will be using several capacitors wired in series to produce the necessary amount of current in our coil. Since the navy launches 45,000 lbs aircrafts the amount of energy storage that is needed is much larger and using lots of capacitors is impractical. The EMALS energy-storage subsystem draws power from the ship and stores it kinetically on rotors of four disk alternators. Each rotor can store more than 100 mega joules, and can be recharged within 45 seconds of a launch, which is much faster than steam catapults. This type of energy storage is ideal for this type of application but since we will be doing a small scale capacitors will do. Another problem that is faced during projects like this is

being able to complete a circuit with such high current. This same problem occurred when testing this project being that the SCR used could only handle 35A which is not nearly as much as the capacitors can discharge. Since the 1 SCR can't handle the amount of current that we are trying to pass through it. In order to combat this issue the use of multiple SCR's that are triggered at the same time which allows for the current to be divided through each SCR reducing the chance of a single one failing. Another challenge while using the SCR's was that even if it can take the amount of current running through it the heat that it generates is very high which is why a heat skink was added to the original design.

#### IV. STRENGTHS OF EMALU

There are many benefits to using an electromagnetic catapult as compared to using old style steam catapults. For instance one advantage is the weight limit that steam catapults are able to launch. Another disadvantage to steam powered catapults is the amount of stress that they put onto the frame of the aircraft carrier when launching planes. Furthermore, the steam powered catapult also occupies a great deal of space on the aircraft carrier which could be used for various other things.

Finally, the steam catapult has many parts to it which often break and can be very difficult to maintain. With the Electromagnetic catapult there are very few parts to moving parts to it and only needs a small amount of space for the capacitor bank.

#### A. Equations

$$L(\mu H) = \frac{.8(NA)^2}{6A + 9B + 10C} \quad (1)$$

#### V. CONCLUSION

After the text edit has been completed, the paper is ready for the template. Duplicate the template file by using the Save As command, and use the naming convention prescribed by your conference for the name of your paper. In this newly created file, highlight all of the contents and import your prepared text file. You are now ready to style your paper; use the scroll down window on the left of the MS Word Formatting toolbar.

#### A. Figures and Tables

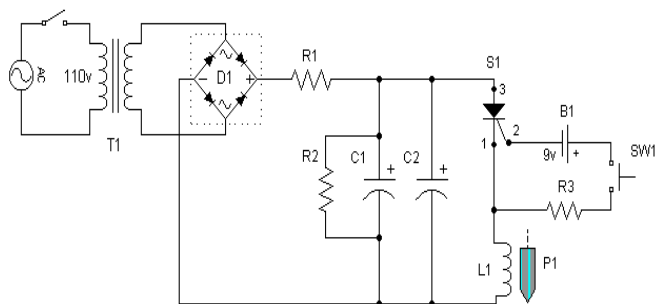
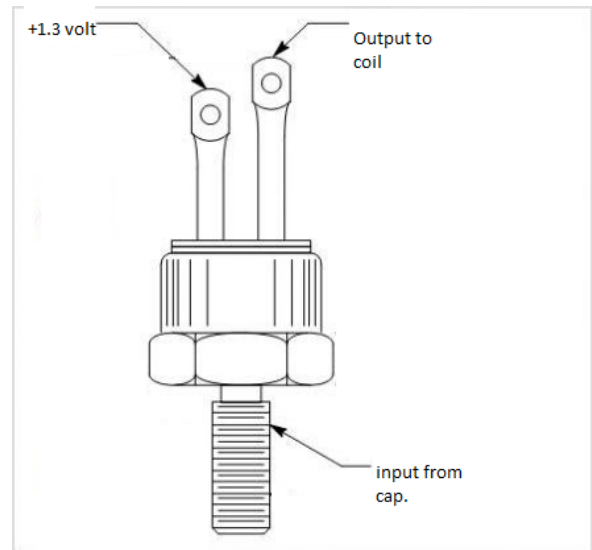

#### ACKNOWLEDGMENTS

Special thanks to Ladimer S. Nagurney Professor of Electrical Engineering at the University of Hartford And Ray Miller Engineering technician at the University of Harford

#### REFERENCES

- [1] M. R. Doyle, D. J. Samuel, T. Conway, and R. R. Klimowski, "Electromagnetic aircraft launch system—EMALS", *IEEE Trans. Magn.*, vol. 31, no. 1
- [2] R. R. Bushway, "Electromagnetic aircraft launch system development considerations", *IEEE Trans. Magn.*, vol. 37, no. 1, pp.52-54 2001
- [3] Becherini. G.: Di Fraia. S.: Tellini. B. "Analysis of the Dynamic Behavior of a Linear Induction Type Catapult". *Plasma Science, IEEE Transactions on*, On page(s): 59 - 64 Volume: 39, Issue: 1, Jan. 2011
- [4] M. N. O. Sadiku, *Elements of Electromagnetics*, 2010.
- [5] I. R. McNab, "Launch to Space With an Electromagnetic Railgun," vol. 39, pp. 295-304, 2003
- [6] A. Monti, C. W. Brice, R. A. Dougal and R. O. Pettus, *Design and Simulation of a Permanent-Magnet Electromagnetic Aircraft Launcher*, vol. 41, no. 2, pp. 566-575, 2005.
- [7] R.J. Kaye et al., "Design and Evaluation of Coil for a 50 mm Diameter Induction Coilgun Launcher," *IEEE Trans. On Magnetics*, vol. 31, no. 1, pp.478-483, January 1995.