

## **Enhancing Understanding of Mechanics Courses using FEA Active Learning Modules**

**Dr. AHM E. Rahman, Pennsylvania State University, Harrisburg, The Capital College**

Dr. Rahman is an assistant professor in the department of Mechanical Engineering. He obtained his PhD from the University of North Dakota. His research interests include Nano MMC, Light Alloy Technology, Physical Metallurgy, Joining of Alloys, Structural Ceramics and Bioceramics.

**Anil Chandra Attaluri, Pennsylvania State University, Harrisburg, The Capital College**

Anilchandra Attaluri received the Ph.D. degree in mechanical engineering with a focus on biotransport and imaging from the University of Maryland at Baltimore County. He received post-doctoral training in magnetic hyperthermia from the Department of Radiation Oncology & Molecular Radiation Sciences, The Johns Hopkins University School of Medicine. Focusing on experimental, preclinical, and finite element analysis, his work resulted in novel applicators and pioneering data for improving magnetic nanoparticle hyperthermia. In 2017, he joined the School of Science, Engineering, and Technology, The Pennsylvania State University - Harrisburg, as an Assistant Professor of mechanical engineering. His research interests include the field of theranostic technologies and systems with an emphasis on devices and image-based modeling. He teaches courses on capstone design, engineering simulations, and computational techniques for biomedical applications.

**Dr. Amit Banerjee**

**Dr. Brian A. Maicke, Pennsylvania State University, Harrisburg, The Capital College**

Brian A. Maicke is an associate professor of Mechanical Engineering and Technology at Penn State Harrisburg. He completed his B.S. degree in Mechanical Engineering at Marquette University and worked as a civil, mechanical, and manufacturing engineer before returning to graduate school, earning his M.S. And Ph. D. degrees in Aerospace Engineering from the University of Tennessee Space Institute. Dr. Maicke serves on the AIAA Hybrid Rocket Technical Committee as Chair of Web Communications. He teaches core courses in thermo-fluids as well as electives related to aerospace engineering. His research focus is on the modeling and simulation of propulsion systems.

# **Enhancing Understanding of Mechanics Courses using Finite Element Analysis (FEA) Active Learning Modules**

A.H.M.E. Rahman, Anilchandra Attaluri, Amit Banerjee, Brian Maicke

*School of Science, Engineering and Technology, Pennsylvania State University –  
Harrisburg  
777 W Harrisburg Pike, Middletown, PA 17057, USA*

## **Abstract**

Finite Element Analysis has become an important simulation tool in academia and industries. To take full advantage of this incredible engineering tool, FEA has been integrated in lower-level mechanics courses such as statics, mechanics of materials, machine design etc. It should be noted that most mechanical engineering undergraduate programs offer FEA as an upper-level technical elective or required course. Although the integration of FEA in mechanics and/or design courses is an existing concept, the practice is limited to the use of FEA software package such as how to create a CAD model, how to set up a problem, and obtain a simulation. Simulation of stress analysis of 2D truss bridge, 2D beam frame using a simulation software can be mentioned as examples. On the other hand, the class-room instructions of mechanics courses are primarily limited to solving problems from different textbooks. The authors propose that the FEA simulation software can be used effectively to enhance the understanding some of the concepts of lower-level mechanics courses. This paper discusses the introduction of FEA active learning modules on combined loading, beam deflection, and critical buckling in mechanics of materials course, a sophomore-level course, and shaft deflection in Machine Design course, a junior-level course. The learning outcomes were discussed in class for each module. The learning outcomes were assessed using following two different ways: 1) conceptual understanding of the content before and after introducing the FEA module was assessed by the assignment grades, and 2) student response on survey questionnaire obtained towards the end of semester. The focus of the assessment and student survey were to determine how effective the integration of FEA package was to understand the concept of any topic in Mechanics of Materials and Machine Design courses.

## **1. Introduction**

Finite Element Method (FEM) and Finite Element Analysis (FEA) simulation software are widely used in research and industries. It has become an attractive tool for product design because it enables shorter development cycles [1-3]. Theory-based basic FEM is offered as graduate-level course or on a few occasions as a technical elective course in Mechanical Engineering or Civil Engineering programs [4]. However, this trend has been shifted. Most undergraduate programs offer FEA course as an upper-level elective and a significant chunk of it is the FEA simulation using commercial software. Industries prefer to use this powerful simulation tool in their design phase. Hence, it requires that the students with an undergraduate engineering degree learn this skill to satisfy the requirements of entry-level engineering

positions. Now the question is how this powerful simulation tool can be utilized in undergraduate engineering curricula where it can strengthen the learning process and grow students' skills.

Occasional attempts have been made to integrate FEM into basic mechanics courses as well as first year design courses. Most FEM integration into mechanics courses are limited to FEM theories. Brinson et. al. [5] introduced 1D beam and 2D triangular elements using stiffness method, Chapalkar et. al. [6] introduced 1D and 2D truss elements using stiffness method in Statics and Mechanics course, and also extended their approach to MATLAB solution of FEM theories and truss problems with 30+ members solved using Ansys only. The Ansys solution provided merely the description of steps and commands. Other attempts [7,8] have been made to integrate FEM into basic mechanics courses were limited to the theories only. However, few examples [9,10] were found where the integration of FEM theories into mechanics was considered insignificant.

The incorporation of FEA simulation into first year design courses has been found in early 1990's. It was understood that a FEM theory was not necessary to learn the usage of FEA simulation. FEA simulation was included as a part of solid modeling in an engineering design graphics course [11]. Ural et. al. [12] have developed a project for first year course incorporating FEA simulation. In that project, the behavior of a SMARTBEAM<sup>®</sup> was examined using experimental measurement and FEA simulation and the results were compared. For all these first year courses FEA was used only as a simulation tool and the philosophy was that the underlying FEA theory or the knowledge of mechanics was not necessary.

Papadopoulos et al. [13] proposed a different pedagogy on integration of FEA practice throughout the undergraduate CE/ME curriculum. They hypothesized that a theory-first approach is neither necessary nor sufficient to exploit the full potential of the capability throughout all of the formative phases of curriculum. They advocated a consistent approach of early and continued exposure of FEA simulation, beginning with the first year, to successive mechanics courses, again without requiring the education FEA theories. In simple words, neither FEA theory nor theories of mechanics are necessary to exploit the advantage of FEA simulation, learning how to obtain an FEA simulation is enough. In this article, it was hypothesized that FEA simulation can be integrated into ME core courses to better understand the concepts of conventional theories in mechanics, heat transfer, and machine design courses. Underlying FEA theories may not be necessary, but the theories of mechanics and heat transfer are important to make the FEA simulation meaningful. Although the knowhow of FEA simulation steps is important, however, just learning them may not be adequate to take the full advantage of this important engineering tool. The integration of FEA simulation serves other purposes too such as learning the steps in simulation in early stage, making an engineering decision based on analysis, learning to use required CAD model and assess the validity of the analysis.

## **2. Integration of FEA simulation and Learning Outcomes**

The FEA simulations are integrated into the following two mechanical engineering core courses:

- a) Strength of Materials (E MCH 213)
- b) Machine Design (ME 360 and MET 365)

*Strength of Materials*

Three different types of problems were discussed in Strength of Materials class. One problem from each of the Buckling of Column, Deflection of Beams and/or Shafts, and Stress Transformation chapters.

- i) Determine if any of the members of the truss will fail by buckling? The truss members are assumed to be pin connected and is made of structural steel rod with a radius of 2 inches. The load  $P$  is 40,000 lb. Elastic modulus,  $E = 29 \times 10^6$  psi

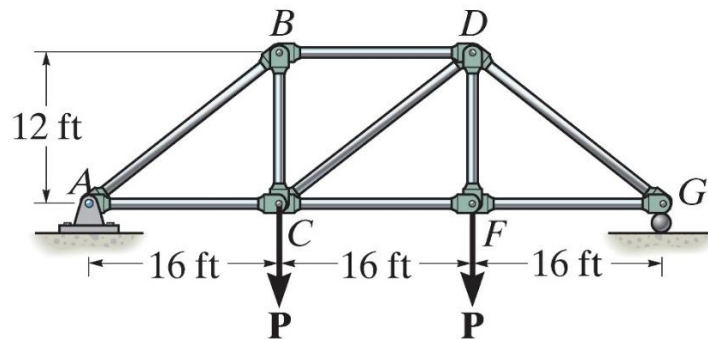

Figure 1: 2D Truss

Analytical solution requires to calculate critical buckling load in all members. Comparing this critical load with the exerted compressive load in members a decision can be made if the truss would fail by buckling. This problem has been simulated in a commercial FEA software Ansys Workbench. The following steps were used:

- 1) Creation of the geometry (CAD) in Ansys Design Modeler.
- 2) Material properties data was created using appropriate material data
- 3) The CAD was imported to Ansys Mechanical, and load and boundary conditions were applied.
- 4) Under solution, axial force, bending moment, shear force, axial stress (direct stress), combined stress and bending stresses were determined.
- 5) The solutions in step 4 were imported to Eigenvalue Buckling analysis in Workbench. Then a load multiplier was determined for each of the member though it mattered for members with compressive force/stress only. A load multiplier of .14 for a member means that the member will fail by buckling only with 14% of the force exerted in that member. If  $P_{\text{buckling}} = \pi^2 EI/L^2 = 2,226$  lb (let's say) and a compressive force in that member is 15,802 lb then the load multiplier is  $2,226/15,802 = .14$ . For this problem the load multiplier minimum is 0.33952 (see Figure 2) which means at least one of the members will fail by buckling only by 33.95 % of the applied load.

*Learning Outcome:* The student learned how to create a CAD using Ansys Design Modeler and the steps required to solve this type of problem using Ansys Workbench. Students can easily figure out the members with compressive stresses (and forces) as can be seen in Figure

2(a). The truss members with blue colors exerted compressive forces. Then using Eigenvalue Buckling Analysis in Ansys the load multiplier was determined. If the load multiplier is less than 1 then failure by buckling occurs. Students compared these results with the analytical solution. Fig. 2 (b) and (c) show two members of truss are failed by buckling. The simulation provided opportunity to the students to observing visually truss members failed by buckling.

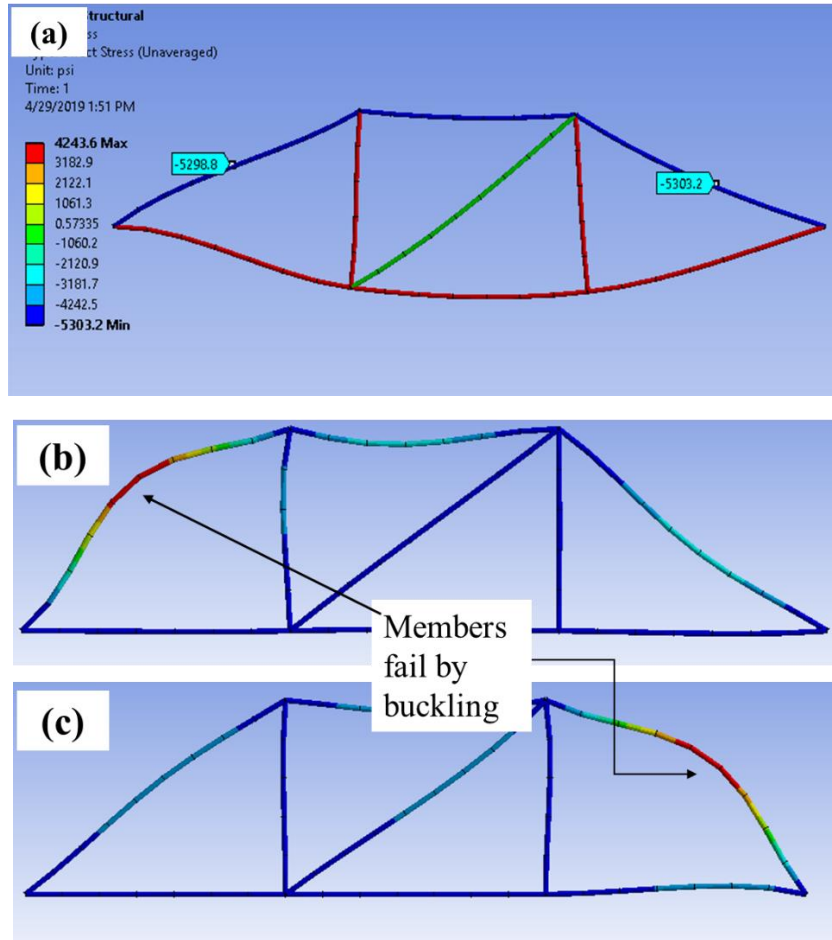

Figure 2: FEA simulation of axial stress in truss members and critical buckling analysis.

- ii) The beam has a rectangular cross section and is subjected to the loading as shown. Determine the combined stresses at point A and point B, which located just to the left of 20 kN force.

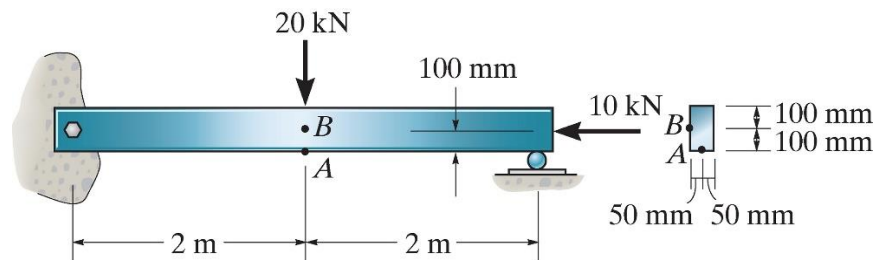

Figure 3: Rectangular beam under combined loading

This is an example of combined loading of bending stress and normal stress. The analytical solution requires to find the normal force, bending moment, normal stress, bending stress and then the combined stress using superposition theory.

Simulation in Ansys workbench involves following steps:

- 1) Creation of the CAD using Ansys Design Modeler and create material database.
- 2) The CAD was imported to Ansys Mechanical and point load and surface load were applied. A fixed boundary condition was applied at the support.
- 3) The elastic curve (Figure 4) helps the students to determine the direction of stress at any point on the beam cross section at any point along the beam length by observing the beam deflection in  $y$ -direction. For example, from the elastic curve it can be determined that the stress on the bottom surface of the beam at the point of interest is tension.
- 4) Then solution was obtained, and maximum and minimum principal stresses, bending stresses, axial stresses (direct stress in Ansys) were found at any point.

*Learning Outcomes:* As usual the student learned how to create a CAD using Ansys Design Modeler and the steps required to solve this type of problem using Ansys Workbench. The students often struggle to apply the superposition theory in a proper way, e.g. if the bending stress would be tensile or compressive on the upper surface and on the lower surface at any location. To understand the concept, the FEA simulation of this problem was break down into three different stages. First, only 10 kN axial force was applied in FEA simulation (Fig. 4(a)), then only 20 kN bending force was applied in the simulation (Fig. 4(b)), and finally, both 10 kN axial and 20 kN bending forces were applied in the simulation (Fig. 4(c)). The simulation provided - 0.5 MPa stress uniformly on any location along the length of the beam. Since the force was compressive the stress obtained was compressive (-ve) also. If the force is tension the stress would be tension (+ve) as well. In this case, the deformation is in axial ( $x$ -direction) direction (to the direction of force). Fig. 4(b) shows the normal stress and deformation of the beam under 20 kN bending load only. The elastic curve of the beam can easily be seen from the simulation. The bending stress at three different locations on a cross section is shown in the image below. From the simulation it can easily be demonstrated (see the stress labels) that the bending stress on the upper fibers (surface) is tensile and compressive on the lower surface for current loading condition. Now, the scenario for combined loading can be understand easily. If the normal stress is needed to be calculated at point A in Fig 3 above, the axial stress and bending stress at that point need to be added algebraically such as  $-0.5$  (compression) +  $8.0804$  (tension) =  $7.5804$ . This method applies to any point on a beam cross section. The concept explained here can be extended to other similar types of problems of combined loadings.

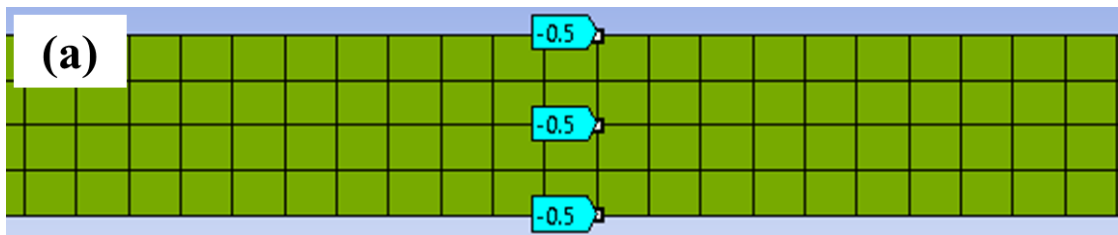

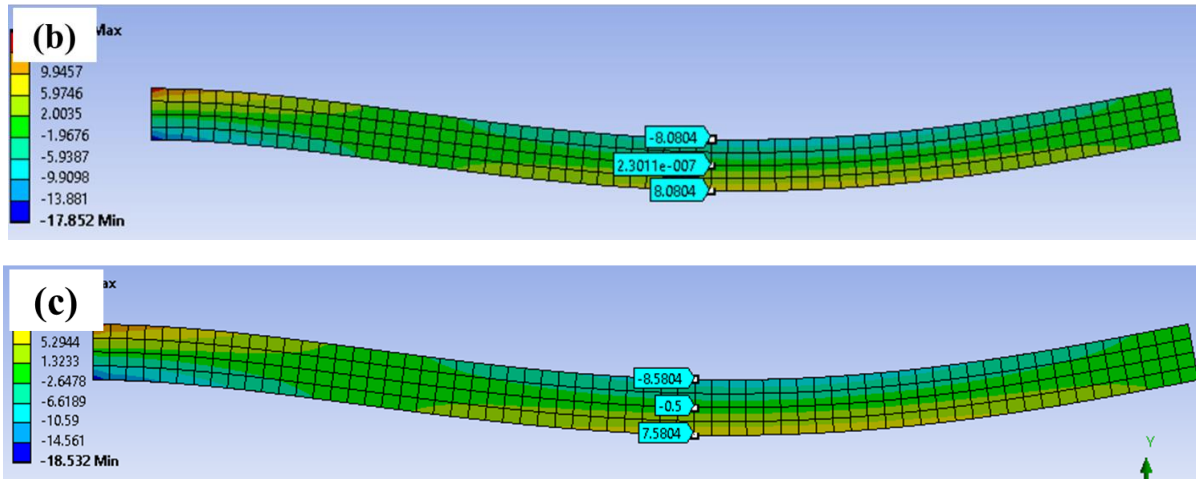

Figure 4: FEA simulation of normal stress under (a) 10 kN axial load only, (b) 20 kN bending load only and (c) axial 10 kN and bending 20 kN load combined [the unit of stress: MPa]

- iii) Determine the elastic curve of the W14 x 30 beam in Fig. 5. Find the deflection at point C and in the middle of support A and B.  $E = 29 \times 10^3$  ksi.

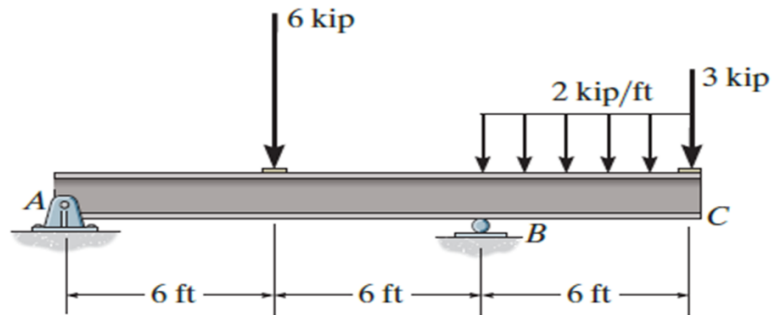

Figure 5: W14 x 30 beam with forces.

The analytical solution of this problem involves finding reaction force and moment at the support A, then generating a moment equation of a segment in terms of  $x$  and finding the equation of beam deflection in terms of  $x$  by integrating the moment equation twice. At the end, applying the boundary conditions the integration constants are calculated and substitute back into beam deflection equation and this equation is used to calculate deflection of the beam at any point. The equation after first integration is used to calculate slope of the beam at any point.

The FEA simulation in Ansys Workbench involves:

- 1) Creation of the geometry in Ansys Design Modeler and create material database.
- 2) The CAD model was then imported in Ansys Mechanical.
- 3) Appropriate boundary conditions and forces were applied and a solution was generated.
- 4) Ansys Workbench provided graphical solution of beam deflection.

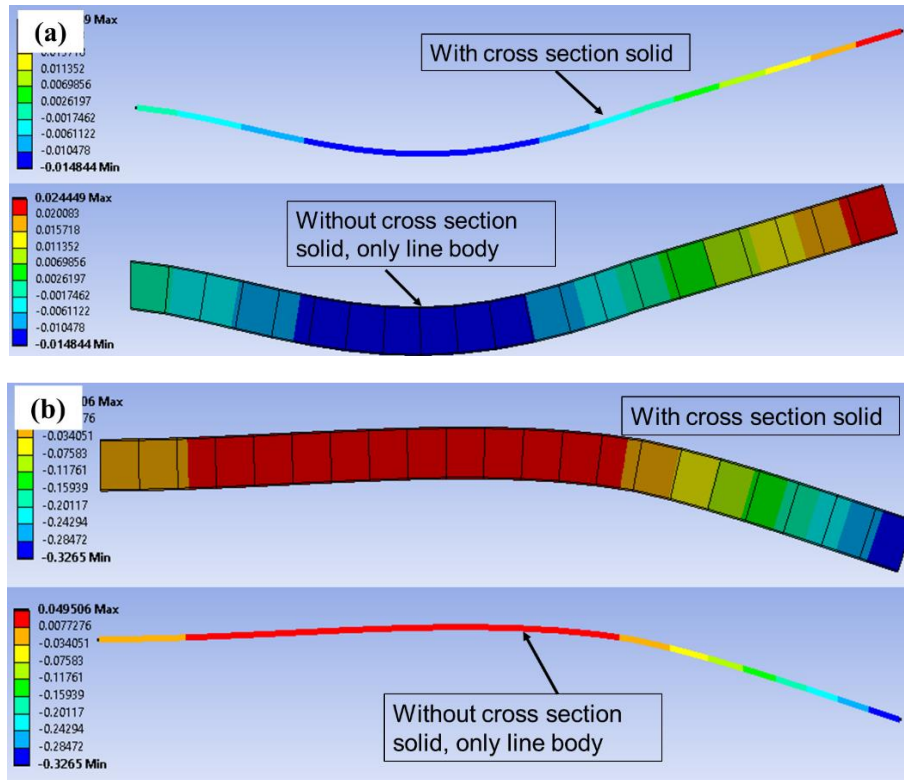

Figure 6: FEA simulation of beam deflection in y-direction (a) with 6 kips force only and (b) with 6 kips, 2kips/ft and 3 kips forces on the beam shown in Fig. 5.

*Learning Outcomes:* Like the two previous problems the students learned the necessary steps required to obtain an FEA simulation in Ansys Workbench. Fig. 6 shows the simulation of beam deflection in y-direction (a) with 6 kips force only and (b) with 6 kips, 2kips/ft and 3 kips forces on the beam shown in Fig. 5. The figures show the views with cross section and without cross section (line body only) to clearly understand the deflection sense. The simulation shows the shape of elastic curves. This helps to easily understand the sign of deflection and slope of the beam at any location of the beam. The student can figure if the deflection/slope would be positive or negative depending on the applied load.

### *Machine Design*

In Machine Design, shaft deflection problems are worked out by hand and do not emphasize numerical methods used in common practice. In a typical classroom setting, deflection of a shaft in bending are solved using estimation by beam table superposition, closed-form successive integration of the bending moment equations, numerical successive integration using the trapezoid rule, and/or energy methods. For a stepped shaft, direct successive integration becomes tedious and energy methods such as Castigliano's second theorem is used if the deflection or slope is required at only a few locations. Numerical methods, such as successive numerical integration or FEA are recommended for detailed analysis and understanding. Students are exposed to all the different methods for stepped shaft deflection calculations with an emphasis on FEA. Students are introduced to steps involved in FEA: Pre-analysis, geometry, mesh, physics



setup, numerical simulation, mesh convergence, and verification and validation. Student teams (2 to 4 students per team) are asked to develop FEA skills using online video tutorials (via Lynda.com) and apply it to design problems from Shigley's Mechanical Engineering Design 10e. Instructor's experience with the self-learning team project in a machine design course has been positive. Students appreciate having multiple chance to successfully solve a problem.

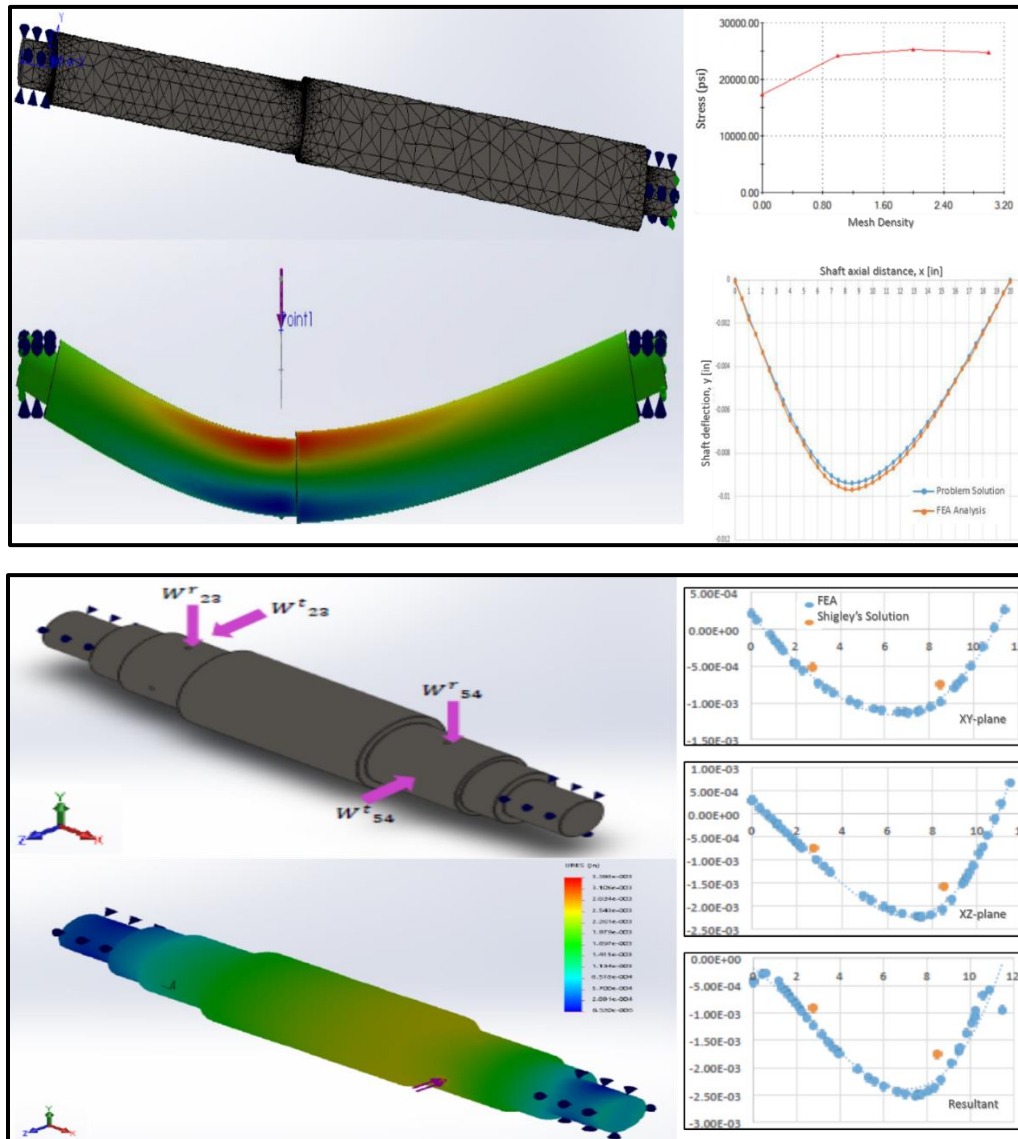

Figure 7: samples of two stepped shaft deflection problems from the student reports.

*Learning Outcomes:* Students demonstrated understanding of the simulation process, ability to translate that fundamental knowledge to commercial FEA packages and verify FEA solutions with analytical solutions. Students were exposed to ASME verification and validation (V&V) standards. Sample simulation results in Figure 7 helps reinforce the relationship between applied load and sign of deflection and slope of the shaft, introduce the concept of mesh sensitivity in FEA, and realize the importance of V&V in the context of model credibility. The expected

learning outcomes of this self-learning student project were to use commercial CAD and FEA package to

- reinforce fundamental understanding of the physics governed design
- estimate stress and deflections for complex shaft geometries
- provide useful graphical representations of the results
- understand influence of boundary conditions on stress and deflections estimates
- understand influence of mesh size on stress and deflections estimates use classical shaft design calculations and literature data to verify and validate the FEA results

### 3. Assessment

The plan for assessment of using of FEA active learning modules into Strength of Materials and Machine Design courses is two-fold. The first one is to give students assignments before and after the introduction of FEA. The second one is to have students answer a survey questionnaire. Samples survey questionnaire for Strength of Materials and Machine Designs and the student responses are added in Appendix A and Appendix B, respectively. The questions were framed in a way to get feedback on how much the FEA integration can help to understand the concept, if the students want more of these types of materials in their courses, and last but not least if these FEA modules increased their interest about learning more about FEA simulation.

A quiz on combined loading asking students to calculate the normal stress on any location on a beam cross section was given before and after the FEA simulation modules were introduced. The following problem (Figure 8) was given as a quiz before the introduction of FEA modules:

Problem: The plate has a thickness of 20 mm and the force  $P = 5$  kN acts along the centerline of this thickness such that  $d = 133$  mm. Determine normal stresses at point A and B on a section a-a.

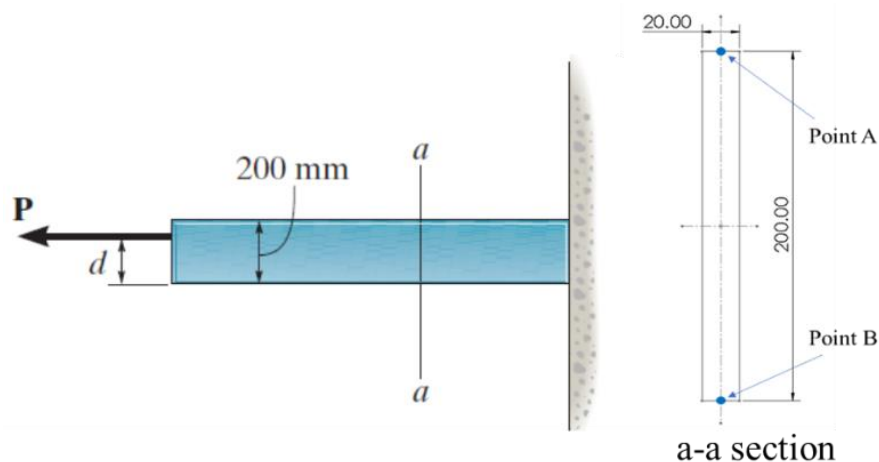

Figure 8: Combined loading problem for quiz before the introduction of FEA.

The following problem (Figure 9) was given as another quiz after the introduction of FEA modules:

Problem: The beam has a rectangular cross section and is subjected to the loadings shown. Determine the normal stress at point A which is located just the left of the 20-kN force. Determine if the stress at point A is in tension or compression.

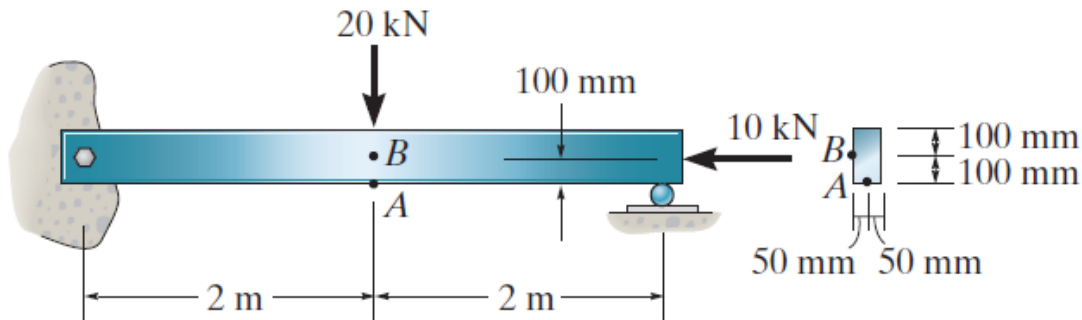

Figure 9: Combined loading problem for quiz after the introduction of FEA.

The average scores on these quizzes were 40.9/50 before the modules were introduced and 44.23/50 after.

The responses from the survey questions indicated that the introduction of FEA active learning modules has increased the student's ability to understand the concept. 15 out of 19 participants either strongly agreed or agreed to that visualizing FEA simulation increased the understanding of the concepts. 18 out of 19 participants either strongly agreed or agreed to see more of these types of FEA modules in Strength of Materials or other courses. 15 out of 19 participants either strongly agreed or agreed that FEA modules showed in class have increased their interest about FEA simulation. The response for survey in Machine Design class indicated that 8 out of 12 participants either strongly agreed or agreed that FEA simulation has helped to improve the understanding of shaft deflection. The responses for other questions also indicated positive impact of using FEA simulation in Machine Design course.

## 5. Conclusions

FEA has been integrated in many different courses from first year to senior level courses. The philosophy of those integration was limited to learning the steps involved in simulation process. In some cases, the underlying mechanics or conventional theories was overlooked let alone the bottom-up FEA theory. It has been argued that the knowledge of conventional theories or FEA theory is not required to learn the FEA simulation. However, the authors philosophy here is not in complete agreement with this. The authors acknowledge that the FEA theory may not require but the conventional theories are important to understand and interpret the results from FEA simulation. In fact, the FEA simulation can be an important tool to understand the concepts. FEA simulation modules explained here with the learning outcomes can be an important philosophy of integrating FEA in mechanical core courses. The assessment of quiz grade before and after the introduction of FEA simulation indicated that it helped the student to enhance the understanding of theories. The student survey strongly favored the proposed hypothesis as well.

## Appendix A

### Survey Questions for EMCH 213

19

Responses

01:02

Average time to complete

Active

Status



Ideas

1. Visualizing FEA simulation results enhanced my understanding of concepts in EMCH 213 - Strength of Materials course.

Strongly Agree	5
Agree	10
Neutral	3
Disagree	1
Strongly Disagree	0



2. Being exposed to FEA in EMCH 213 - Strength of Materials my desire for signing up for the FEA technical elective class increased.

Strongly Agree	4
Agree	10
Neutral	4
Disagree	1
Strongly Disagree	0



3. FEA modules provided in EMCH 213 - Strength of Materials were adequate to accomplish the FEA related in-class activity.

Strongly Agree	5
Agree	11
Neutral	3
Disagree	0
Strongly Disagree	0



4. I would like to see more of this type materials in my EMCH 213 - Strength of Materials course and other courses in future.

Strongly Agree	4
Agree	14
Neutral	1
Disagree	0
Strongly Disagree	0



5. FEA simulation modules showed in class increased my interest about FEA simulation and I would like to learn more about it.

Strongly Agree	7
Agree	8
Neutral	3
Disagree	1
Strongly Disagree	0



## Appendix B

### ME 367 - Machine Design FEA Shaft Deflection Survey

12

Responses

00:58

Average time to complete

Active

Status

1. Using Finite Element Analysis (FEA) in ME 367 - Machine Design has helped improve my understanding of shaft deflection.

Strongly agree	2
Agree	6
Neutral	4
Disagree	0
Strongly disagree	0



2. Being exposed to FEA in ME 367 - Machine Design my desire for signing up for the FEA technical elective class increased.

Strongly agree	1
Agree	4
Neutral	5
Disagree	2
Strongly disagree	0



3. FEA training modules on Lynda.com or other online resources in ME 367 - Machine Design were adequate to accomplish the shaft deflection project.

Strongly Agree	1
Agree	3
Neutral	6
Disagree	1
Strongly disagree	1



4. I would like to see more of this FEA based projects in ME 367 - Machine Design.

- Strongly Agree 0
- Agree 6
- Neutral 1
- Disagree 2
- Strongly disagree 0
- Other 3

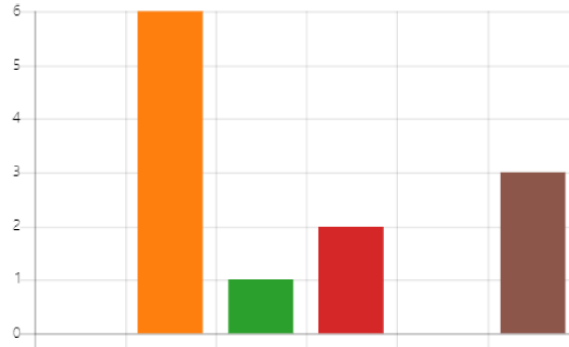

## References

1. Thilmann, J. (2000), Analyzing up Front. *Mechanical Engineering*, October: 88-91.
2. Thilmann, J. (2001), FEA in a Snap. *Mechanical Engineering*, July: 60-62.
3. Mahoney, D. P. (1999), Go with the Flow. *Computer Graphics World*, March 3: 30-36.
4. Watson, K.A., Brown, A.O., Liu, J. (2015), Finite Element Analysis Active Learning Modules Embedded Throughout A Curriculum: Implementation and Assessment of Results Based on Student GPA, Proceedings of the 2015 American Society for Engineering Education Annual Conference and Exposition.
5. Brinson, L.C., T. Belytschko, B. Moran, and T. Black. (1997), "Design and Computational Methods in Basic Mechanics Courses, *Journal of Engineering Education*, Vol. 86, No. 2.
6. Chaphalkar, P. and D. Blekhman. "Introducing Finite Element Analysis in the First Course of Statics and Solid Mechanics", in Proceedings of the ASEE Annual Conference & Exposition, Honolulu, HI, June 2007.
7. Earley, R.D. "Use of FEA in an Introductory Strength of Materials Course" in Proceedings of the ASEE Annual Conference & Exposition, Seattle, WA, June, 1998.
8. Zhao, J. "Teaching Finite Element Analysis as a Solution Method for Truss Problems in Statics", in Proceedings of the ASEE Annual Conference & Exposition, Salt Lake City, UT, June 2004.
9. Boronkay, T.G. and J. Dave. "Introduction of Finite Element Methods in the Lower Division Mechanical Engineering Technology Curriculum", in Proceedings of the ASEE Annual Conference & Exposition, Milwaukee, WI, June, 1997.
10. Pike, M. "Introducing Finite Element Analysis in Statics", in Proceedings of the ASEE Annual Conference & Exposition, Albuquerque, NM, June 2001.
11. Krueger, T.J. and R.E. Barr. "The Feasibility of Teaching FEA in a Freshman Graphics Course", in Proceedings of the ASEE Gulf-Southwest Annual Conference, Texas A&M University-Corpus Christi, 2005.
12. Ural, A. and J. Yost. "Integration of Finite Element Modeling and Experimental Evaluation in a Freshman Project", in Proceedings of the ASEE Mid-Atlantic Annual Conference, Villanova University, October 2010.
13. Papadopoulos, J. Papadopoulos, C. and Prantil, V.C. "A Philosophy of Integrating FEA practice throughout the undergraduate CE/ME curriculum," in proceedings of the American Society for Engineering and Education Annual Conference, Vancouver 2011.