

Harvesting Energy using Piezoelectric Materials for a Pacemaker

Xavier Mirza, Amir Ali, Thomas Reyes, Jonathan Zea

Computer Engineering Technology
Engineering Technology Department
University of Houston

Abstract

A pacemaker is a small sophisticated unit that helps to regulate heart's rhythm. This is performed by sending a small electric stimulation to the heart. The doctor places the pacemaker under the skin on patient's chest, just below the collarbone. It's connected to the heart with tiny wires. Pacemakers' main purpose is to keep the heart beating properly by maintaining the heartbeats, which helps the body get blood, oxygen and food that it needs. Pacemakers are useful in many cardiac conditions which can disrupt the heart's normal electrical system. They are mostly used for patients who may have slower heart rates caused by sinus syndrome or heart blocks. They usually eliminate the symptoms often caused by bradycardia including weakness, fatigue, lightheadedness, dizziness, or loss of consciousness. Pacemakers do not take over the work of the heart as it's responsible to function on its own. Rather, the pacemaker merely helps to regulate the timing and sequence of the heartbeat.

The replacement of a pacemaker has some negative effects on the patients, such as the cost of a surgery to replace a pacemaker is \$45,000. There are complications that may be caused during the surgery or during the recovery time such as infection, and mainly the trauma of going through a surgery itself such as patients who have phobia of needles, anesthesia, or hospitals. The additional cost of the procedure with associated medical care varies greatly depending on the hospital that the patient receives the pacemaker. In an outpatient setting, where the procedure is done on the same day of discharge or the day prior to discharge, the average cost is over \$2,000 plus the cost of the pacemaker. However, for the inpatient setting, where the patients are admitted to the hospital, the average cost can be over \$60,000. If the surgery is repeated there is a risk of damage to the blood vessels or the nerves near where the pacemaker is implanted, according to MayoClinic.com. There is also a risk that a lung may collapse during the procedure if it is punctured or that the heart may be punctured, according to MedlinePlus. Sometimes the surgery can cause an abnormal heart rhythm. Other side effects of the surgery include a risk of infection, swelling, bruising, bleeding or an allergic reaction to the anesthesia given during the procedure.

Our goal is to eliminate the need for this extra surgery for such crucial device and the risks that are involved for doing so. Our idea is simple: Covert mechanical energy into electrical energy and use it as a power source for the pacemaker instead of a battery. We will capture the vibrations of the human heart using the piezoelectric energy harvesters and convert it into electrical energy and provide a power source for the pacemaker, thus eliminating the need for an extra surgery in order to replace a battery.

Introduction

Pacemakers are very important and crucial medical device that stimulates the heart by electrical impulses in order to keep it beating at a healthy rate. The pacemaker is inserted through a surgery that can take up to 90 minutes. The pacemaker is made up of three parts. First is the generator, this is the computer and battery. Second is the connector, this is where the leads are attached. Lastly is the leads, these are the wires that link the heart with the pacemaker.

Our Self-Powered Pacemaker is a device that functions just like any Pacemaker in the market, but instead it creates power independently from the battery using piezoelectric harvesters, which uses the vibrations from the heartbeats and converts them into electrical energy and harvests them into the capacitors. The stored energy is utilized as a power source for the pacemaker.

Background

Our interest in energy harvesting led us to believe that we can take apart a complex device such as a pacemaker and eliminate its battery as the primary power source. We introduced this idea to few medical professionals such as Dr. Macknoja, a cardiologist, and Dr. Curran, PHD in Neurology. Their enthusiasm and inputs for this topic gave us motivation to design a complete product for demonstration. The main complexity of this project dealt with the piezoelectric sensors since our application needs sufficient power to work. Since we cannot use an actual human heart to test our theory, we created a mimic heartbeat model using Arduino microcontroller. This required us to create a complex C code which is listed in Appendices of this paper. Our project's primary goal is the cost reduction for patients. The replacement surgery and the risks associated can be an alarming factor for patients' health.

Product Requirements

- Breadboard – For testing purposes.
- Capacitors – To store the energy.
- Arduino UNO – To create a heartbeat model
- Oscilloscope – To get our energy readings.
- Vibration Motors – To mimic the heart vibrations.
- LTC3588-1 chip – To mount it onto the heart.
- Aluminum enclosure – To place the circuit inside.
- Fake Heart Prop – To mimic the actual heart with a motor inside
- Piezoelectric Energy Harvesters – To convert vibrations into electrical energy

Design Alternatives

Designing a pacemaker's circuit was not complicated. We were given an actual pacemaker donated by Hall Garcia Medical facility for testing purposes. We used the dremel tool to pry open the titanium covering. Our original goal was to use the actual circuit from that pacemaker. Unfortunately the manufacturer had a tamper protection liquid inside the pacemaker which destroys the circuit if anyone cuts open the pacemaker. Although, the circuit was useless, it gave

a great picture of how we can build a pacemaker from scratch. Any pacemaker's circuit is a full-wave bridge rectifier consisting of four diodes in series with capacitors to hold the charge into.

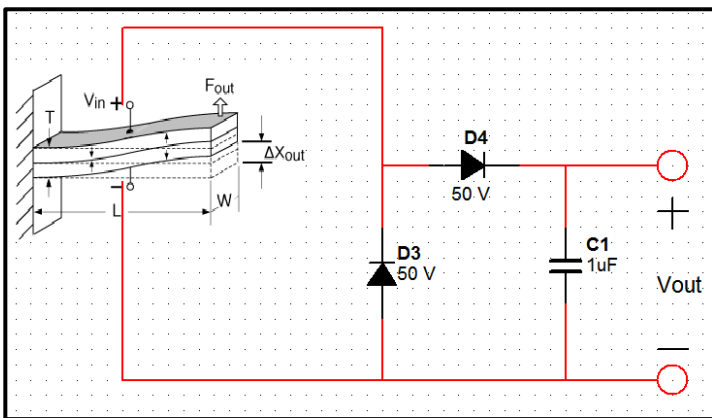
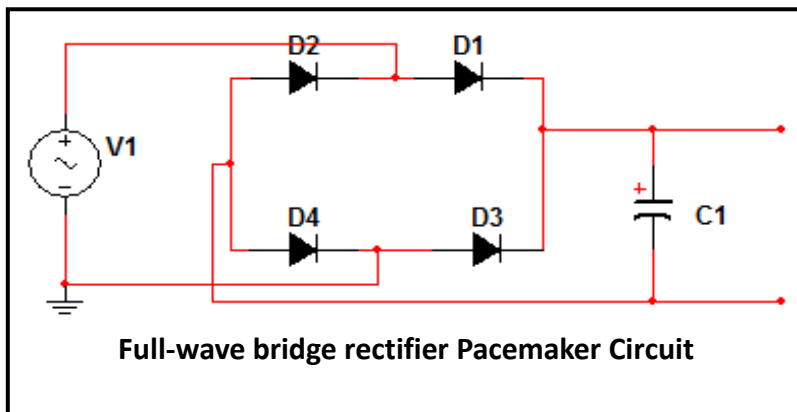

Piezoelectric Sensor used as a Power Source

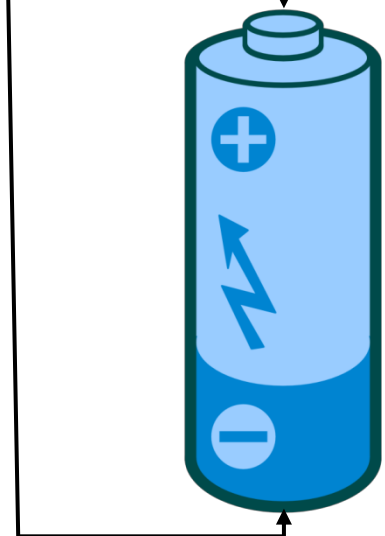

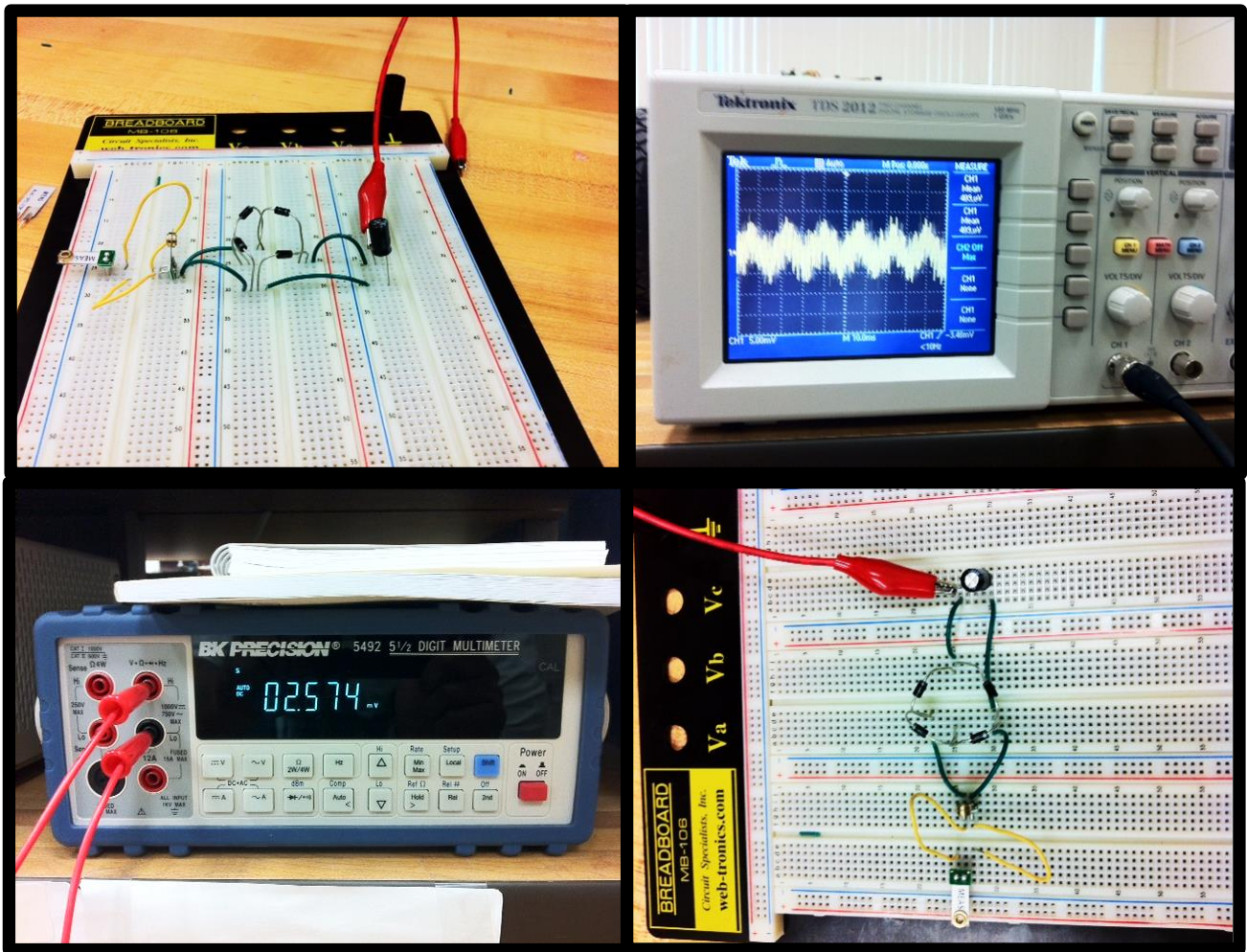

Piezoelectric Energy Harvesting Rectifier Pacemaker Circuit with Piezoelectric Minisense100 Vibration Sensors

While conducting our research, we came across Volture Vibration Energy harvesters that are created by MIDE Engineering group. The Volture Piezoelectric Energy Harvester uses the piezoelectric effect to convert normally wasted mechanical energy in the form of vibrations into useable electrical energy. Any application where sensing is needed and there is a consistent vibration to harvest from can benefit from the Volture. This harvester was clamped at its base to allow for resonant frequency energy harvesting. This ensures that the clamp line (front of the clamp) is around 0.2" over the edge of the piezoelectric ceramic is efficient and safe operation.

Polarity: Pins 1&3 = V+, Pins 2&4 = V-.

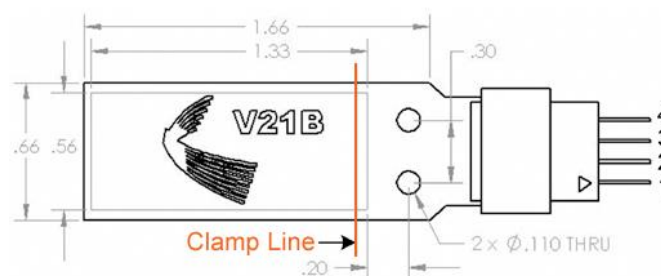

Volture Piezoelectric Energy Harvester

*Energy Harvesting using Piezoelectric Materials for a Pacemaker,
University of Houston College of Technology, March 8, 2013.
Copyright © 2013, University of Houston Engineering Technology Department*

Product Layers



Specifications - v22b	
Application type:	energy harvesting
Frequency Range (Hz):	120 - 360
Harvesting Bandwidth (Hz):	2
Device size (in):	1.4 x 0.24 x 0.025
Device weight (oz):	0.045
Active elements:	1 stack of 2 piezos
Piezo wafer size (in):	1.00 x 0.15 x 0.01
Device capacitance (nF):	nominal: 10.2, maximum: 14.2

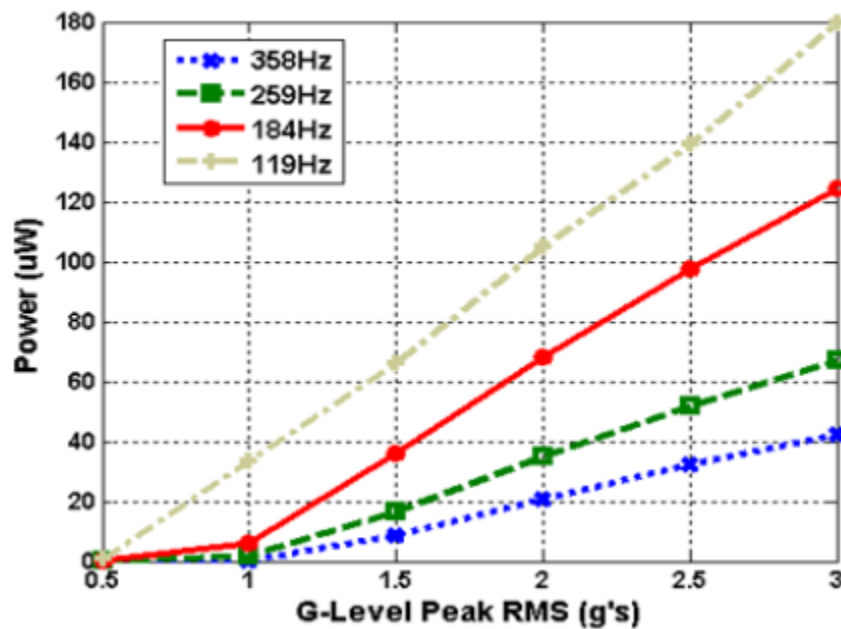

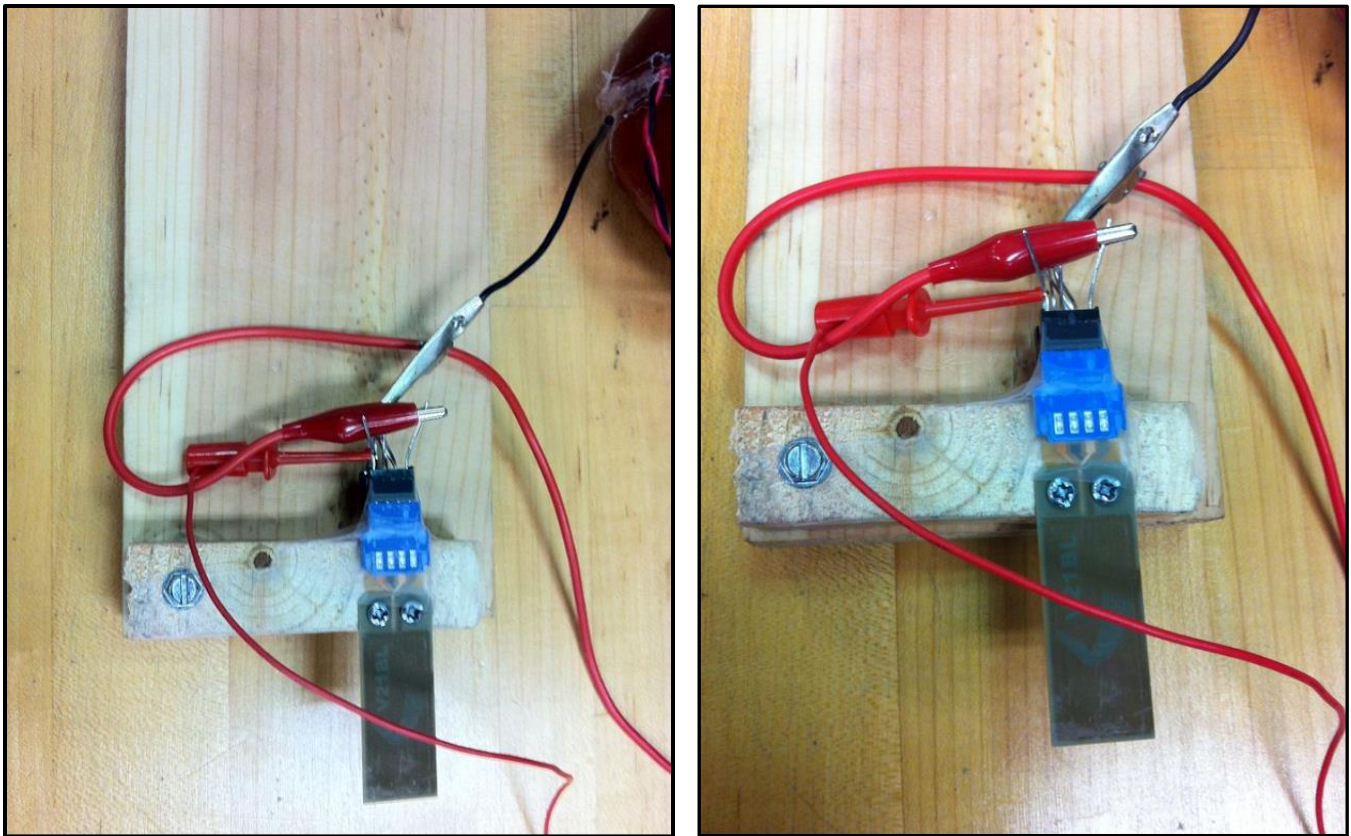

Volture Energy Harvesters connected with our Pacemaker Circuit

Unfortunately, after vigorous testing, we concluded these harvesters were not what we are trying to accomplish in our project. They were designed mainly for higher frequency applications and since pacemaker's frequency is very low, these harvesters were not ideal and dropped from our design. Going back to our original design of full-wave bridge rectifier circuit, we came across a problem: The capacitors we had were leaking the charge really fast, and were not sufficient to hold for a longer period. After doing more research we found a LTC3588-1 chip which was perfect for our project. Therefore, we finalized our circuit using The Minisense100 piezoelectric Vibration sensor mounted parallel onto LTC3588-1 chip.

Design Specifications

The LTC3588-1 integrates a low-loss full-wave bridge rectifier with a high efficiency buck converter to form a complete energy harvesting solution optimized for high output impedance energy sources such as piezoelectric transducers. An ultralow quiescent current under-voltage lockout (UVLO) mode with a wide hysteresis window allows charge to accumulate on an input capacitor until the buck converter can efficiently transfer a portion of the stored charge to the output. In regulation, the LTC3588-1 enters a sleep state in which both input and output quiescent currents are minimal. The buck converter turns on and off as needed to maintain regulation.

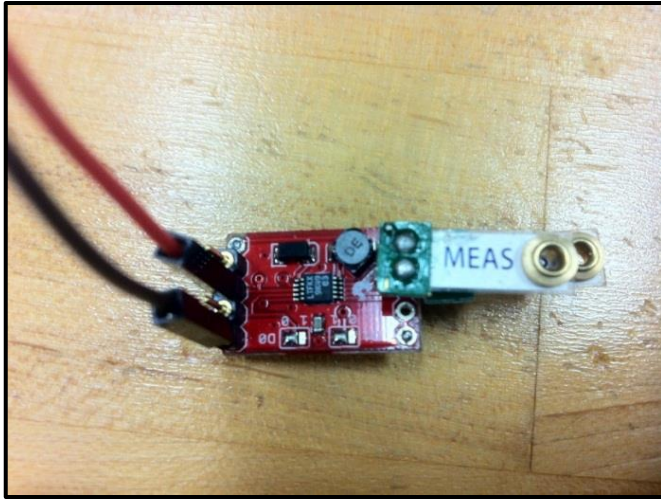

LTC3588-1 Chip with Minisense100 piezoelectric Vibration sensors mounted parallel

LTC3588-1 3.3V Regulator Start-Up Profile

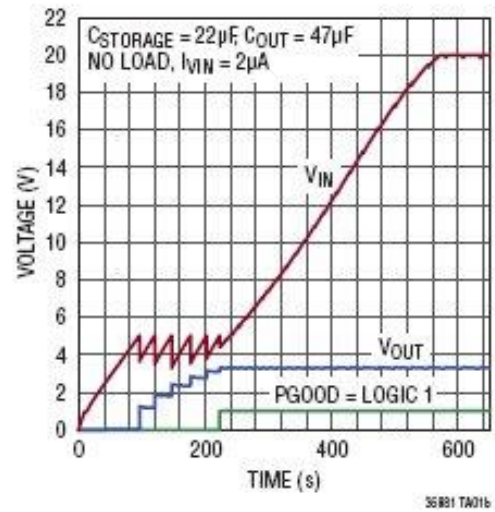

100mA Piezoelectric Energy Harvesting Power Supply

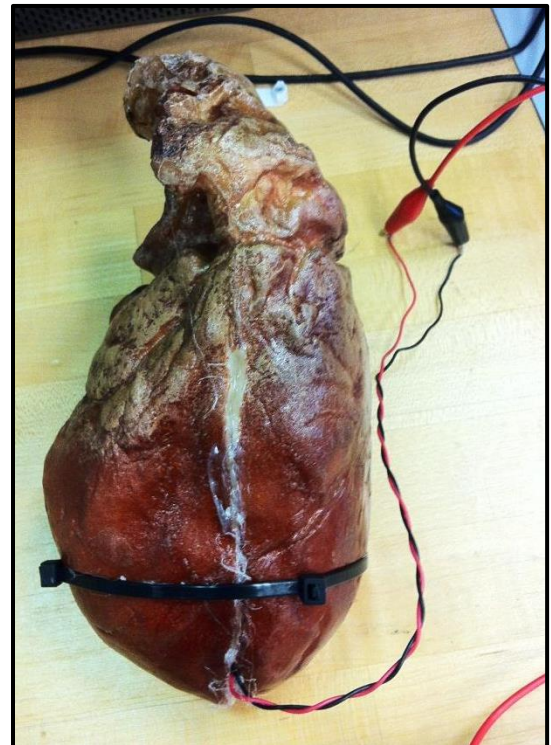
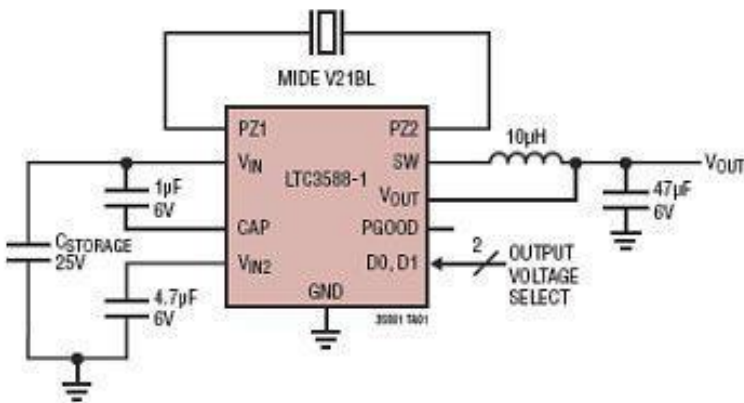

Foam Modeled Heart with DC Motor mounted inside

The piezoelectric material is an AC voltage source which means that the voltage will shift from positive to negative as it is moving up and down. To convert the AC voltage to DC voltage, a diode bridge rectifier is implemented in the circuit design.

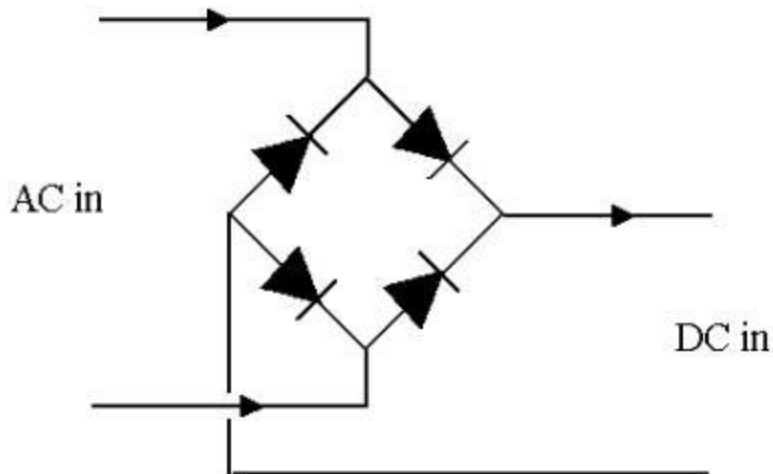

The conversion from AC to DC occurs as only the positive input remains on the upper path of the diode rectifier and the negative input remains in the lower diodes. By using this process, all of negative waves are converted to positive as shown in figure above. The capacitor across the output terminals is required to smooth the ripples as the flow of current is rectified.

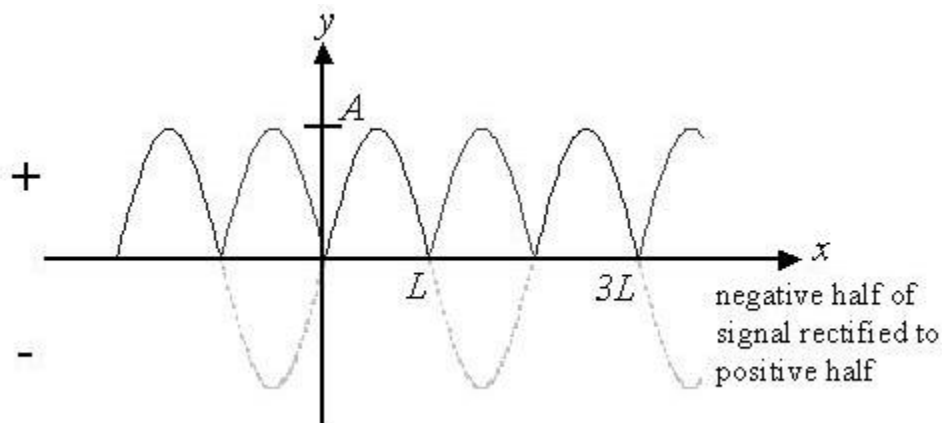

Once the AC input has been rectified to DC output, the output then goes through a buck-boost converter circuit. The circuit consists of a reversed biased diode, inductor, capacitor and a switch. The buck-boost converter is a type of DC to DC converter that has an output voltage that is greater or less than the input voltage. One of the most noticeable characteristic of the buck-boost converter is that it changes the polarity of the output voltage opposed to that of the input.

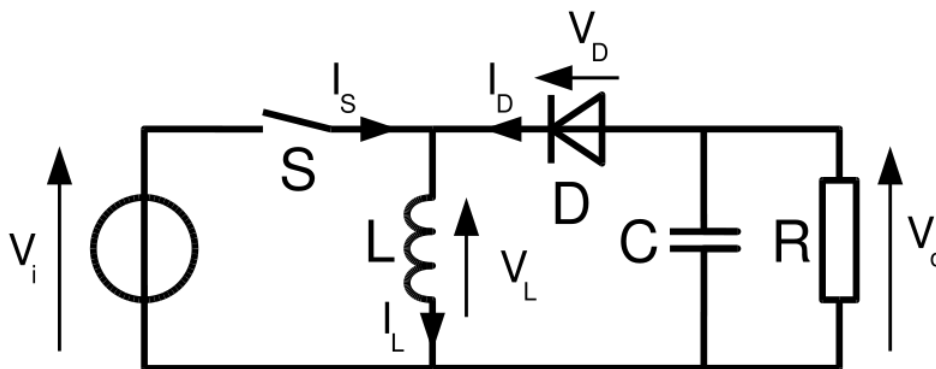

When the switch is in the on/closed state, the input voltage source is directly connected to the inductor (L). This results in the inductor storing the energy. In this state the capacitor is used to supply energy to the output load. When the switch moves to off/open state, the inductor is connected to the output load and capacitor in which the energy is transferred from the inductor to the capacitor and the load. The rate of change in the inductor current I_L in the on state is given by the following equation (eq 1):

$$\Delta I_{L_{on}} = \int_0^{DT} d I_L = \int_0^{DT} \frac{V_i}{L} dt = \frac{V_i DT}{L} \quad \text{eq (1)}$$

D is the duty cycle. It represents the fraction of the commutation period T during which the switch is on. Therefore D ranges between 0 (S is never on) and 1 (S is always on). During the off state, the switch is open so the inductor current flows through the load and this can be expressed by the following equation (eq 2).

$$\Delta I_{L_{off}} = \int_0^{(1-D)T} d I_L = \int_0^{(1-D)T} \frac{V_o}{L} dt = \frac{V_o(1-D)T}{L} \quad \text{eq (2)}$$

After finalizing all the components a simulation of the circuit was created in Multisim software (see figure below). The circuit was fully designed on the software with parts, diode rectifier circuit and the buck-boost converter circuit.

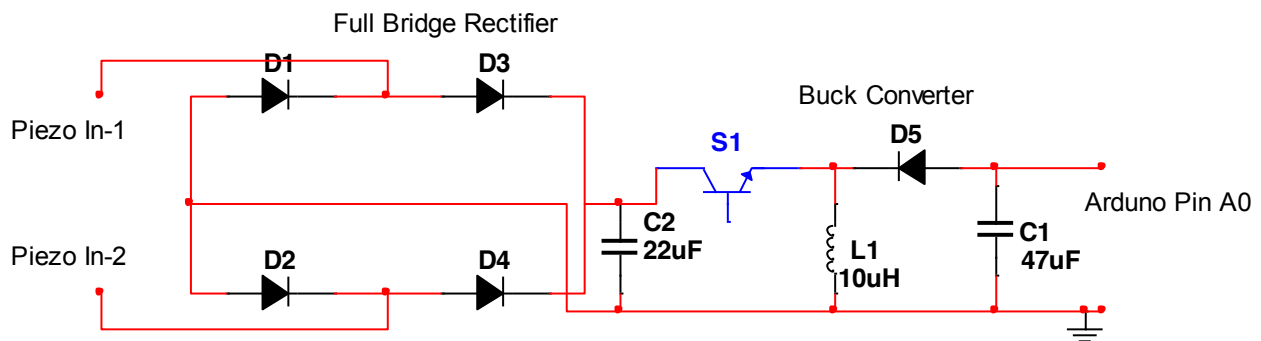

A LTC3588 breakout board was acquired for this project as it had all the necessary components required. The size of the prototype was essential to the design as this entire circuitry will be placed in a human body. With the limited tool and hardware, a prototype was prepared. Following image shows the LTC3588 pin outs and components attached to the chip (figure below).

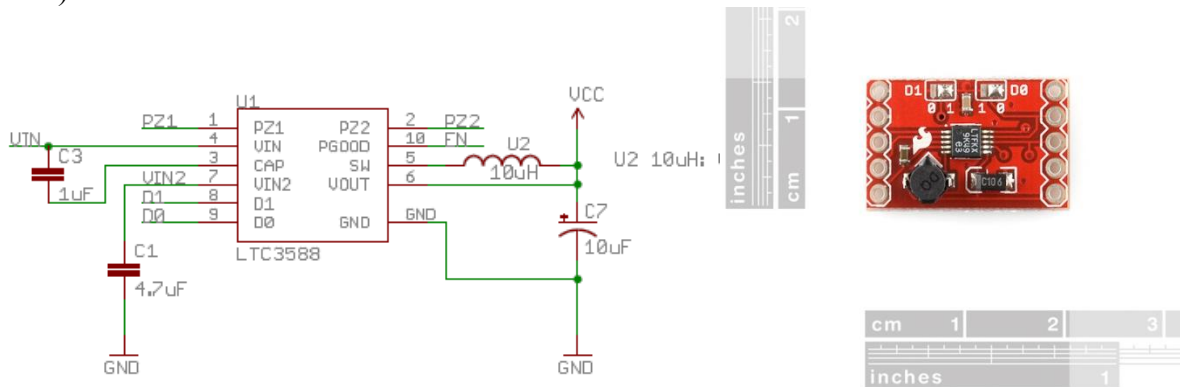

Once the prototype was completed a graphical user interface (GUI) was developed to show the

harvested energy from the piezo-electrical material. The gui consists of two separate programs. The first program is used to feed the analog signal (voltage) to the Arduino microcontroller to convert the value from analog to digital format. This task is achieved using the Analog to Digital Converter chip that is on board of the microcontroller. Once a signal is received by the microcontroller, the process of converting the analog signal to digital signal takes place at which point the microcontroller sends the collected data to the serial port of the Arduino.

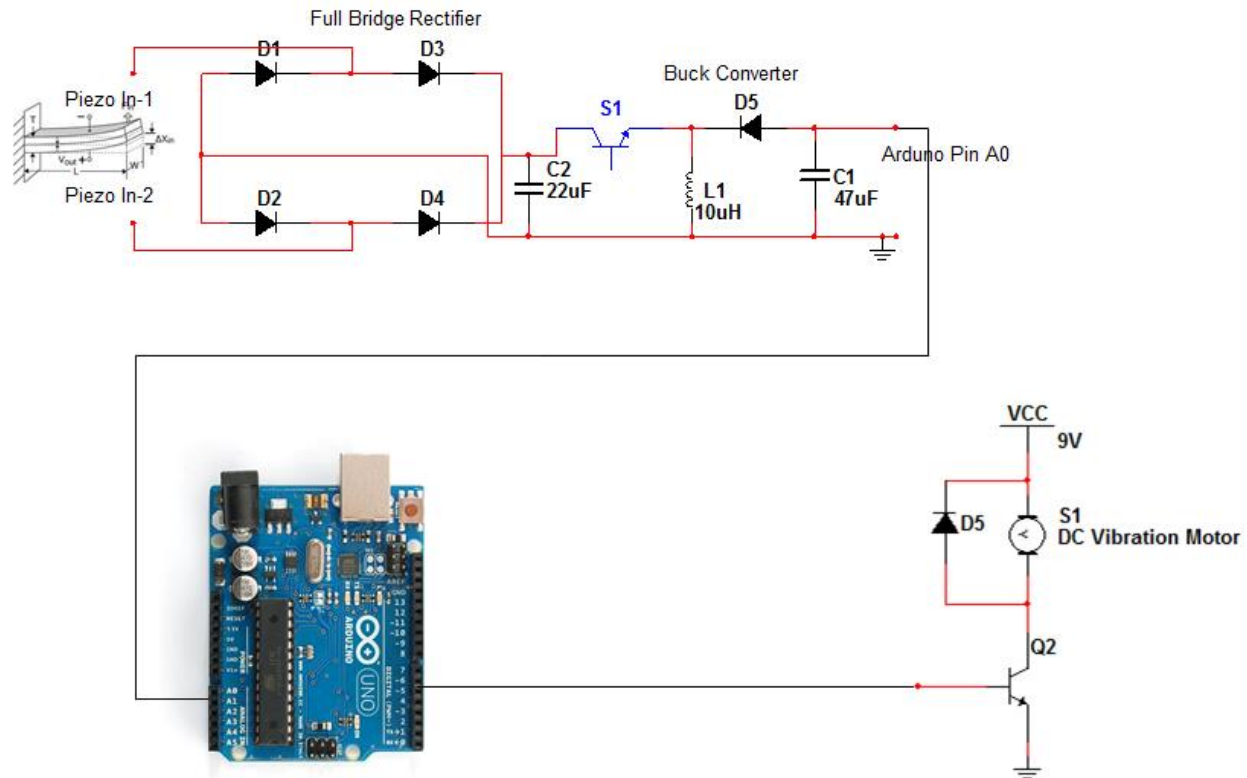

LTC3588-1 - Piezoelectric Energy Harvesting Power Supply

Features

- 950nA Input Quiescent Current (Output in Regulation – No Load)
- 450nA Input Quiescent Current in UVLO
- 2.7V to 20V Input Operating Range
- Integrated Low-Loss Full-Wave Bridge Rectifier
- Up to 100mA of Output Current
- Selectable Output Voltages of 1.8V, 2.5V, 3.3V, 3.6V
- High Efficiency Integrated Hysteretic Buck DC/DC
- Input Protective Shunt – Up to 25mA Pull-Down at $V_{IN} \geq 20V$
- Wide Input Undervoltage Lockout (UVLO) Range
- Available in 10-Lead MSE and 3mm × 3mm DFN Packages

The next phase of the gui involves processing the data that is collected from the serial port of the Arduino. The gui is developed using the Processing IDE software. Processing uses a combination of java and C++ programming language. The gui shows the level of voltage that is being stored in the capacitor that is harvested from the piezoelectric material. Below are the gui screenshots:

*Energy Harvesting using Piezoelectric Materials for a Pacemaker,
University of Houston College of Technology, March 8, 2013.
Copyright © 2013, University of Houston Engineering Technology Department*

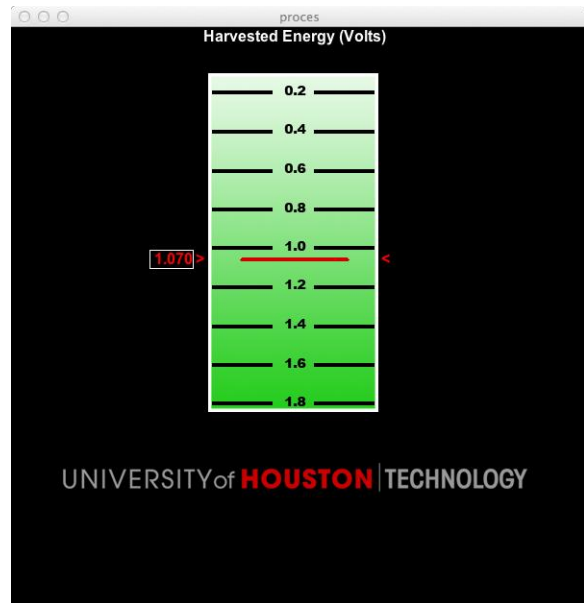
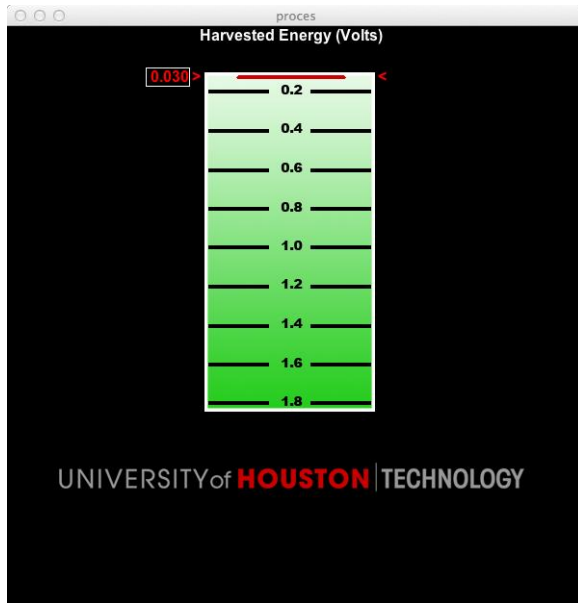

Design Description

The basic principle behind a piezoelectric material is that it takes the linear electromechanical interaction between the mechanical and the electrical state in crystalline materials with no inversion symmetry. The first thing that needs to be understood is the piezoelectric effect which describes the relationship between a mechanical stress and an electrical voltage in solids.

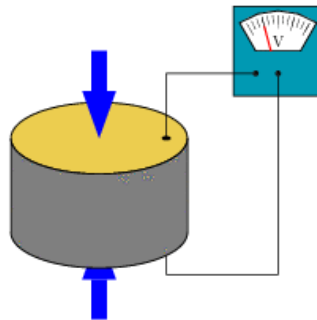

Piezoelectric properties

Figure above shows the relationship between the mechanical and electrical state in which when the material is stressed, it results in a voltage as an output.

This project involves the use of piezoelectric material to take the vibration that are caused by the heartbeat and convert it into a power source which will charge the battery of the pacemaker.

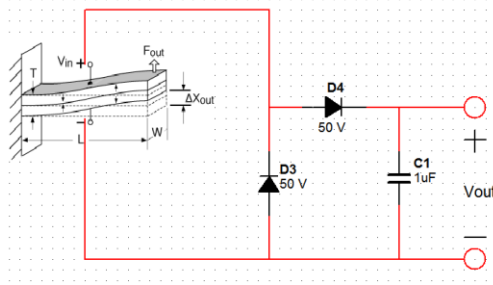

Figure 1: Sensor Circuit

This effect of piezoelectric material is achieved by creating voltage through vibration is reversible. This means that an applied mechanical stress will generate a voltage and an applied voltage will change the shape of the solid by a small amount.

There are two main groups of piezoelectric materials which are crystals such as quartz and ceramics such as PZT. Piezoelectric materials can be used as power sources, sensors, and actuators. However, the main focus of this project will revolve around the use piezoelectric material as a power source.

One of the most important aspects of this project was to be to harvest maximum power. This was done when both, piezoelectric circuit and pacemaker circuit, were impedance matched (can be seen in Design Alternatives section). When two circuits are impedance matched, this allows for the maximum power transfer to take place. This also ensures that no power is being wasted or lost.

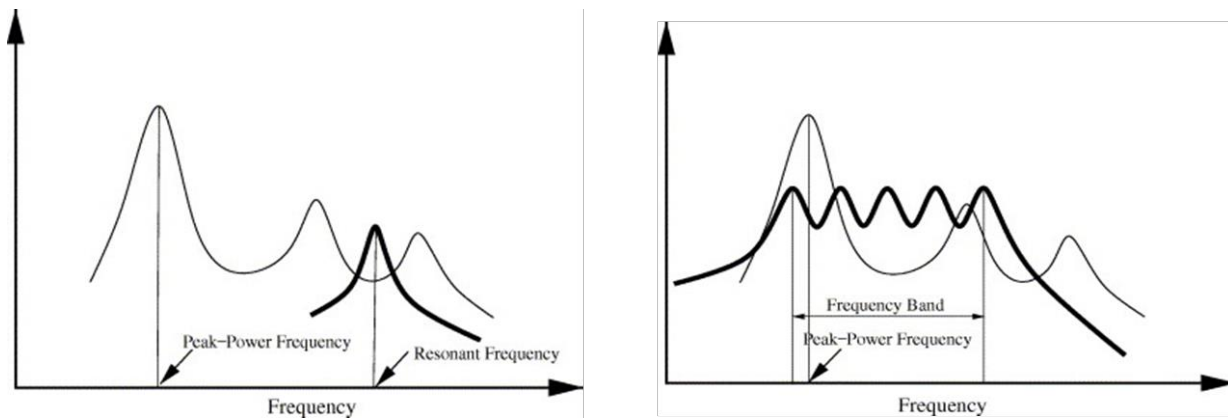

Figure 2: Maximum Power Transfer

As the figure 3 above show, that both parts of the circuits, the sensor and the pacemaker circuits, must have the same resonant frequency as well as the impedance for there to be maximum power transfer.

Another aspect of the project focused on was the human anatomy as it tends to reject foreign materials. To correct this issue we protected our circuit with titanium cover so that the body does not cause the device to be rejected.

Construction Details

In order to fabricate this project, you would need to buy an LTC3588-1 with two Minisense100 piezoelectric Vibration sensors showed in design specifications. Then you would need to mount these sensors in parallel by soldering them with each of its pin. You would also need a DC motor which will mimic the heartbeat connected to the Arduino microcontroller as showed in Design Specifications. You would need to buy a modeled heart to place the motors inside of it and you would need to find the spot with most accurate vibrations.

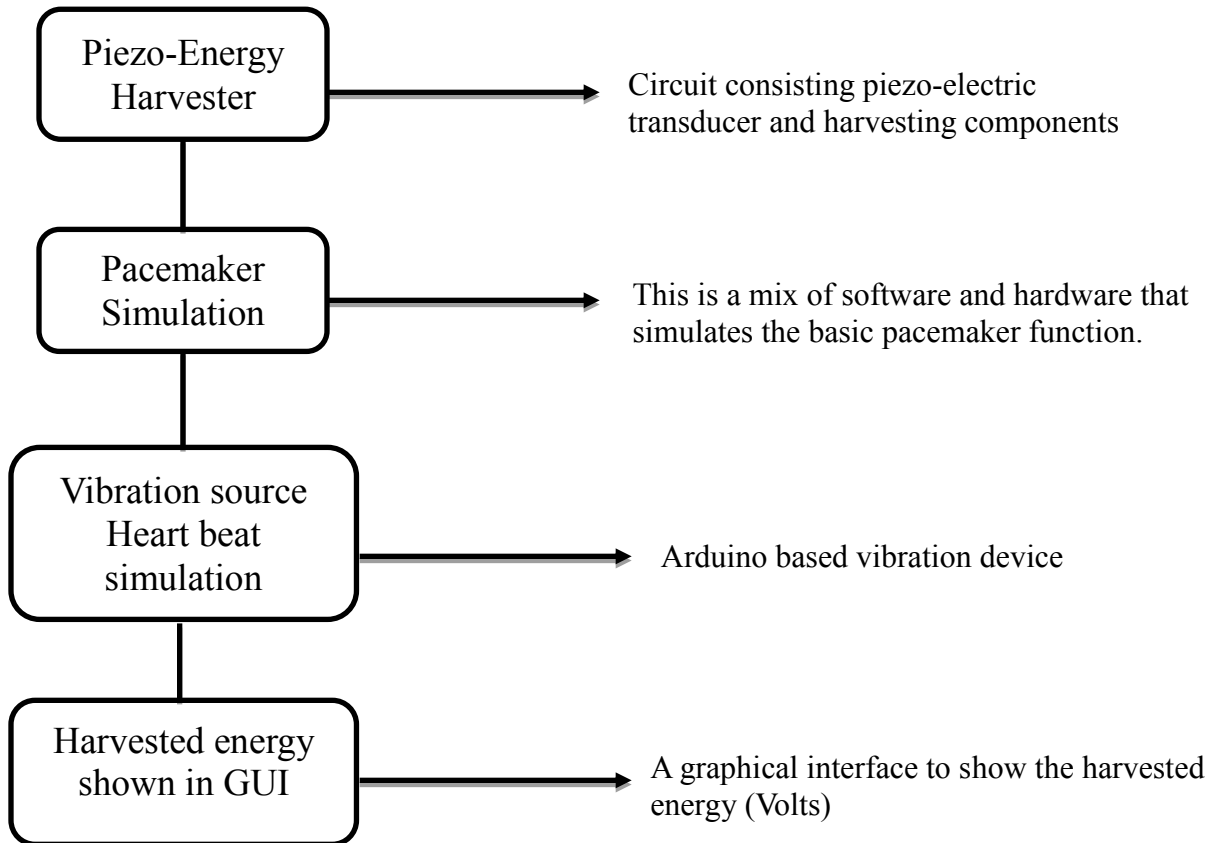

Cost Analysis

Financial usage reporting		
<u>Item</u>	<u>Est. Cost</u>	<u>Actual Cost</u>
PS3 Controller for Motors	\$59.00	Free
Minisense100 Piezoelectric harvesters	\$4.00	\$4.00
Arduino mini	\$39.00	\$39.00
Heart Model	\$50.00	\$110.00
LTC3588 Chip	\$30.00	\$40.00
Totals	\$182.00	\$193.00

Ultimately this project will cost in the range of \$10,000 - \$12,000 in the market, which includes an actual pacemaker, labor, tools and equipment, and sensors. Although our actual cost was \$350, this cost is mainly based on a conceptual project. Our goal was to have a demonstrative project which can be implemented using sufficient industry tools and can be sent for human trial.

Conclusion

We were successfully able to complete our goal for harvesting the energy using heart vibrations model. Although originally we had planned to work with an actual pacemaker, but unfortunately the manufacture had a tampering protection liquid on it which destroys the circuit if opened. After doing a bit more research we came across Vulture energy harvesters, but after vigorous testing we concluded that those harvesters were for higher frequency devices instead of a pacemaker. Hence, we designed our own way of harvesting energy using miniSense100 piezoelectric sensors that converts the heart's vibrations and converts them into electrical energy mounted parallel with LTC3588-1 that integrates a low-loss full-wave bridge rectifier with a high efficiency buck converter to form a complete energy harvesting solution optimized for high output impedance energy sources such as piezoelectric transducers.

User Instructions

In order to use our product a person needs to be licensed as a medical surgeon capable of performing pacemaker surgeries. It is not meant to be tampered with by the patients or any other medical professionals.

Appendices

- **C Program for GUI, which shows the output voltage whenever the heart vibrates, combined with the heartbeat model:**

```
const int analogInPin = A0; // Analog input pin that the potentiometer is attached to
const int analogOutPin = 9; // Analog output pin that the LED is attached to
int sensorValue = 0; // value read from the pot
float outputValue = 0; // value output to the PWM (analog out)

void setup()
{
  Serial.begin(9600);
}

void loop()
{
  sensorValue = analogRead(analogInPin);
  outputValue = fmap(sensorValue, 0, 1023, 0.0, 5.0);
  //map the adc values to 0-5v
```

```

// print the results to the serial monitor:
Serial.println(outputValue);
delay(100);
heartBeat(0.6);

}

float fmap(float x, float in_min, float in_max, float out_min, float out_max)
{
return (x - in_min) * (out_max - out_min) / (in_max - in_min) + out_min;
}

void heartBeat(float tempo){
if ((millis() - prevMillis) > (long)(heartBeatArray[hbeatIndex]* tempo)){
hbeatIndex++;
if (hbeatIndex > 3) hbeatIndex = 0;

if ((hbeatIndex % 2) == 0){
digitalWrite(LEDpin, HIGH);
delay((int)heartBeatArray[hbeatIndex]);
digitalWrite(LEDpin, LOW);
}
hbeatIndex++;
//Serial.println(hbeatIndex);
prevMillis = millis();

}
}

```

References

1. Bhaskaran, M., Sriram, S., Ruffell, S. and Mitchell, A. (2011), Energy Materials: Nanoscale Characterization of Energy Generation from Piezoelectric Thin Films (Adv. Funct. Mater. 12/2011). Advanced Functional Materials, 21: 2165. doi: 10.1002/adfm.201190041
2. Energy Independence: Perpetual Motion is the Way to Go. Ken Amis
<<http://www.lhup.edu/~dsimanek/museum/kamis.htm>>
3. Electromagnetic Induction Studies. ALAN D. CHAVE
<http://www.who.edu/science/AOPE/people/achave/Site/Next_files/24.pdf>
4. Fröhlig G, Schwerdt H, Schieffer H, Bette L. Atrial signal variations and pacemaker malsensing during exercise: a study in the time and frequency domain. *J Am CollCardiol.* Apr 1998;11(4):806-13.
5. Leguan Jo Ann. Heart-Powered Pacemaker in the Future?. <<http://pacemakerpeople.com/11/heart-powered-pacemaker-the-future/>>
6. Love CJ. Pacemaker Troubleshooting and Follow-Up. In: Ellenbogen KA, Kay GN, Lau CP, Wilkoff BL, eds. *Clinical Cardiac Pacing Defibrillation and Resynchronization Therapy*. 3rd Ed. Philadelphia, PA: Elsevier; 2007:1005-1062.
7. Maton, Anthea; Jean Hopkins, Charles William McLaughlin, Susan Johnson, MaryannaQuon Warner, David LaHart, Jill D. Wright1 (1993). *Human Biology and Health*. Englewood Cliffs, New Jersey, USA: Prentice Hall. ISBN 0-13-981176-1. OCLC 32308337.
8. The Cost of pacemaker and surgeries
<<http://www.cardioabroad.com/pacemaker-replacement.php>>

XAVIER MIRZA



Xavier is currently an engineering student seeking his Bachelor of Science in Computer Engineering. He is an active member and an officer for Institute of Electrical Electronics Engineers (IEEE). He is currently employed by University of Houston as an IT Specialist. His main interests include: creating and manipulating hardware with software. Some of his projects include: Laser Security Alarm using a light dependent resistor, controlling an RC Car with an iPhone wirelessly using Arduino microcontroller and C programming. Benchmark tests on ARM7 processor with an Intel core i3 processor through Assembly and C programming.

AMIR ALI



Amir is a graduate student at University of Houston pursuing his Master of Science in Engineering Technology - Network Communications. He received his Bachelor of Science in Computer Engineering Technology in December 2012. He is the author of a project called "iLOOP", which is a smart endoscope that uses sensors to make endoscopy safer and more effective. He earned an award for the "most creative design" at the American Society for Engineering Education and Society of Manufacturing Engineers.

THOMAS REYES



Thomas is currently an engineering student seeking his Bachelor of Science in Computer Engineering. His main interest is in Apple iOS products. He likes to tamper with the hardware and software to implement useful ideas for daily users of these products. He is currently employed for a business that deals with various issues with all kinds of mobile devices and tablets.

JONATHAN ZEA



Jonathan graduated from University of Houston in December 2012. He received his Bachelor of Science in Computer Engineering Technology. He is currently employed by Siemens as a field engineer. His main interest includes in electrical circuits. He likes to create and manipulate circuit designs for a better and efficient use for consumers