

2006-2383: HIGH ENROLLMENT, EARLY ENGINEERING COURSES AND THE PERSONAL RESPONSE SYSTEM

Mark Urban-Lurain, Michigan State University

Mark Urban-Lurain is Director of Instructional Technology Research and Development in the Division of Science and Mathematics Education at Michigan State University. He is responsible for providing vision, direction, planning and implementation for using technology mathematics and science education and developed several introductory computer science courses for non-computer science students serving 2000 students per semester.

Jon Sticklen, Michigan State University

Jon Sticklen is an Associate Professor in the Department of Computer Science and Engineering at Michigan State University. He has a strong research record in knowledge-based systems. His main contributions have been in the theory and application of task specific approaches and in model-based reasoning. Dr. Sticklen has led the effort to rejuvenate the MSU College of Engineering freshman gateway course in computational tools.

Neeraj Buch, Michigan State University

Dr. Neeraj Buch is an Associate Professor of Civil and Environmental Engineering at Michigan State University since 1996. He received his M.S. from the University of Michigan, Ann Arbor and his Ph.D. from TexasA&M University. For the academic year 1998-99 he was selected as a Lilly Teaching Fellow at Michigan State University. His research interests include pavement analysis, design and rehabilitation, performance modeling, non-destructive testing of pavements, high performance concrete, portland cement concrete durability issues, fiber reinforced concrete.

High Enrollment, Early Engineering Courses and the Personal Response System

Abstract

The Personal Response Systems (PRS or “clickers”) is one of the latest technologies to make its way into the classroom. Recent advances in the technology of these systems has reduced the costs and increased the ease-of-use of these systems, so that more faculty are considering using these systems in their classes. This paper reports on the experiences of faculty who used PRS for the first time in two, high enrollment engineering courses: an introductory computer science course enrolling approximately 250 students and an introductory statics course enrolling approximately 200 students. The instructors used different approaches with the PRS questions. In the computing course, the students’ correct answers were worth 30% of their final grade. In the statics course, students received 5% of the grade for participating in the PRS questions, regardless of the correctness of their answers. In both courses, student participation in the PRS questions and the correctness of their answers were positively correlated with their performance in other parts of the course. In both courses, it appears that students with lower GPAs who participated in PRS questions benefited as much as or more than other students, suggesting that using PRS may help students who are at-risk academically.

Introduction

Personal Response Systems (PRS or “clickers”) are hand-held transmitters that allow students to respond to questions in class, with their responses recorded on the instructor’s computer. These systems allow instructors to move away from didactic lecture formats towards more active learning strategies that encourage student participation and are consistent with research on active learning¹. Perhaps one of the best-known advocates for this approach is Eric Mazur, who uses clickers as part of his peer-instruction model in teaching conceptual physics².

Over the past year, PRS technology has moved from infra-red (IR) systems to radio-frequency (RF) systems. The IR systems are line-of-sight, meaning that the students must point their transmitter towards a receiver. Furthermore, the only feedback students had that their responses were received was to watch for their clicker number to scroll across the display on the instructor’s computer. Using the IR systems in large (200+) lecture halls requires multiple receivers to be installed permanently in the lecture classrooms. The logistics of having equipment installed in the classroom, having students all entering their responses concurrently and seeing their clicker number scroll across the screen made their use in large classes daunting. With RF systems, the technology is not line of sight and a single receiver that plugs into the USB of the instructor’s computer can receive all of the responses from several hundred students. The systems are two-way so that students’ handheld units confirm to each student when her or his response has been recorded. Several textbook publishers are now bundling PRS with textbooks and are encouraging faculty to adopt the textbook/PRS packages. However, incorporating a PRS into a class requires the instructor to consider what changes will be required in the instructional design to make optimal use of this technology.

This paper reports on the use of PRS in two high enrollment early engineering courses at Michigan State University. One course, Computer Science and Engineering 131, has approximately 250 students per semester, meeting once per week in lecture and in scheduled lab sessions throughout the week. The second course, Civil Engineering 221 has approximately 200 students per semester and meets for three lectures per week.

CSE 131

The Computer Science and Engineering Department at MSU has a long history of offering a service class as an introductory, computer tools, engineering gateway course. The course is currently numbered CSE 131. Stretching back over a decade, the course evolved from a FORTRAN course, to a course mostly focused on EXCEL and a simplified, locally implemented programming language, and finally to its current state emphasizing problem solving with MATLAB in a context of group work.

CSE 131 is a required course for all majors in the MSU College of Engineering with the exception of Computer Science, Computer Engineering, and Electrical Engineering. (These majors require a starting course in C++.) Most students in the course are either freshman or sophomores, with around 15% enrollment of upper division students (juniors or seniors). About 70% of the students are engineering students; about 20% are students from the MSU College of Natural Science (physics, chemistry, molecular biology, ...); and the residual 5% or so are from other areas. The number of students enrolling from the natural sciences has been growing over the last five years.

Currently, the enrollment for CSE 131 is approximately 250 students for both autumn and spring semesters, and approximately 30 students for summer semester. Class enrollment has been declining over the last five years, which is a reflection of generally declining engineering enrollments both at MSU and on a national basis. Enrollment hit a high point of approximately 400 students per term in 2001.

CSE 131 is a lecture/lab course. Students meet in lecture once per week in an 80-minute session, and in two lab meetings per week both for 80-minute sessions. Students enroll in one of two lecture sections of approximately 125 students each, and in one lab section of approximately 10-15 students each.

Traditionally CSE 131 has followed the standard pattern in which material is introduced in lecture, then in lab students work problems based on material from the lecture. Over the last two years, we have conducted experiments to determine the optimal timing: lecture-before-lab, or lecture-after-lab. In the non-traditional lecture-after-lab approach, the lecture plays the role of summarizing the material the students have gone through, and particularly highlighting any common errors or misunderstanding that have surfaced in the lab work. Of course, in the lecture-after-lab treatment, students must read background material before they go to lab; meaning that students cannot avoid assigned readings. The results of our most recent study comparing lecture-before-lab to lecture-after-lab appears in these proceedings³.

The general “class week” of students in CSE 131 is that (a) they read the assigned readings for the week, (b) they go their lab sections which are run by a TA/consultant who will help them with the problem sets that are assigned, and (c) they go to lecture for a wrap up session on the week’s work. Grade weighting by category for fall term, 2005, (the target for this report) is the following: final exam, 10%; midterms (2), 20%; in-lab quizzes, 40%; in-lecture “clicker” quizzes, 30%.

Many studies have reported the effect that attendance has on concept formation and final student outcomes⁴⁻⁹. Therefore, the CSE 131 instructor set the grade weighting for quite high for the clicker component to enhance lecture attendance and student engagement in lecture.

CSE 131 is delivered and administered in a paperless manner, using a thin application for work flow management/course management that was developed locally on a base of Lotus Notes/Domino. Facilities included all handin of for-grade material with the exception of the clicker tests and the final examination, and stretched to include automated grading of submitted MATLAB functions.

Lecture is conducted partly with the aid of Power Point presentations, which are made available to the students after lectures. At the beginning of each lecture, students answered a few recall questions based on the readings. These questions were not intended to have students do higher order tasks such as synthesis or analysis¹⁰. This clicker quiz is largely to encourage students to read the text before class. After the initial short quiz, the remainder of the 80 minute lecture is divided into 15-20 minute parcels in which (a) an aspect of MATLAB programming is reviewed, ending usually with application of the facet to a problem, then (b) students are asked to work in informal groups on a problem applying the principle covered, (c) the instructor discusses with students their solution paths, then (d) shows a MATLAB version for one solution path. Finally (e) a clicker question for grade is given to the students with a clear, short time to work.

Example of Clicker Question

An example a clicker question from the section of the course dealing with MATLAB array creation is shown in Figure 1.

Multiple Choice

1. What is the value of x?
x = [1:3:12, 9:-2:4]

- a. [1 3 6 9 12 9 7 5 3]
- b. [1 3 6 9 7 5 3]
- c. [1 4 7 10 9 7 5]
- d. [1 3 12 9 4 2]

ANS: C

Figure 1: MATLAB clicker question

This is a simple question, but the incorrect answers that students could choose reflect their concepts for vector creation in MATLAB. The colon operator in MATLAB

A:B:C

starts at a number A, begins iteratively adding the number B to the last entry, and continues until the operation yields a number larger than C. In the example shown, there are two applications of the colon operator. The two vectors produced are then concatenated using the square bracket operator.

The first colon operator application, 1:3:12, produces the vector

[1 4 7 10].

The second colon operator application, 9:-2:4, produces the vector

[9 7 5]

The concatenation of the two yields the correct answer, C,

[1 4 7 10 9 7 5].

Answer A is wrong for both of the applications of the colon operator. The misconception a student could have is that colon operator necessarily must use the third argument in the produced vector. If a student believes that incorrect concept, then the student will be prone to make the error that the second element in the sequence is 3 (instead of 4), and hence up with a “reasonable” looking sequence ending with 12.

Answer D is also incorrect, and would belie a more severely flawed understanding of the colon operator. Answer D could be developed by a student who understood the colon operator as simply taking the three arguments and forming a vector from them – i.e., the student would not understand the implicit iteration of the operation.

Results in CSE 131

Students were required to use their clickers for in-lecture quizzes on the majority of lecture days: there were nine lectures with clicker quizzes. 45% of the students attended all of them, 28% attended 8 lecture classes, 13% attended 7 classes. Only 8 students attended 4 or fewer lectures.

Since 30% of the students’ grade was based on the clicker quizzes, we analyzed the relationship between attendance and student performance on the clicker quizzes with student performance in

other parts of the course. Because attendance was not normally distributed, we computed ranks for attendance before analysis.

Attendance was positively correlated with all types of graded work in the course. As expected, attendance correlated highly ($r=.500, p < .001$) with the score on the clicker quiz. Obviously, students had to attend class to complete this assignment and earn a score. However, attendance in lecture also correlated with the individual ($r = .253, p < .001$) and group tests ($r = .328 p < .001$) that students completed as part of their lab sections, that meet separately from the lecture. Attendance correlated with the midterm exams ($r = .219, p < .001$) and the final exam ($r = .273, p < .001$).

Recall that the clicker questions targeted two learning goals. The first was to encourage students to prepare for lecture by reading the textbook before coming to class. The second type of questions was interspersed throughout the lecture and assessed the students' ability to understand and apply the material. While lecture attendance alone correlates with student performance, performance on the clicker quizzes is a strong predictor of performance in the other aspects of the course. Scores on the clicker quizzes correlate with the individual ($r = .578, p < .000$) and group ($r = .554, p < .000$) lab tests, midterm scores ($r = .558, p < .001$) and final exam scores ($r = .571, p < .001$).

We wanted to understand the impact of the change in instruction on students of differing academic ability. Cumulative GPA is usually the most reliable predictor of performance in subsequent classes. For these students, GPA strongly predicts total points earned in the course ($r = .714, p < .001$). We used the students' GPA as an indicator of academic ability and ranked the students into three groups based on GPA. The distribution of Total Points earned in the course and GPA for each group are shown in Table 1.

Table 1: CSE 131 Distribution of Total Points and GPA by GPA group

Percentile Group based on GPA	Variable	Mean	Std. Deviation
Low N = 82	Total Points	59.37	15.21
	GPA	2.23	.51
Middle N = 82	Total Points	70.85	7.58
	GPA	3.03	.14
High N = 82	Total Points	80.77	9.57
	GPA	3.59	.24

We examined the relationships between attendance and performance in each group. The results are shown in Table 2. Only significant correlations ($p < .05$) correlations are shown. The impact of clickers is not consistent across groups. For the middle GPA group of students, attendance is not correlated with performance on any part of the course except for the clicker quiz questions, where the correlation is the lowest of the three groups. The actual results of the clicker quiz questions only correlate with the midterm exam scores for the middle students.

For the high GPA group, attendance is positively correlated with performance in all areas except for the midterm exam and the scores on the clicker quizzes are positively correlated with scores in all other parts of the course.

For the low GPA group, attendance and clicker quiz scores appear to have a positive impact. While attendance is not correlated with the individual lab test or midterm, it does correlate with the group lab tests (more than any other group) and the final exam score (almost as much as in the high GPA group.) It has the strongest relationship with clicker quiz scores of any group of students, suggesting that the low GPA students who come to class are making a substantial effort to prepare for, and participate in, the quizzes. These efforts appear to pay off, with the scores on the clicker quizzes for this group have a strong relationship with performance on all other parts of the course for this group. What is particularly striking is the strength of the correlation with the final exam.

Table 2: Correlations between attendance and clicker quiz by GPA group

	Low GPA		Middle GPA		High GPA	
	Attendance	Clicker Quiz	Attendance	Clicker Quiz	Attendance	Clicker Quiz
Individual Lab tests	N.S.	r = .523 p < .001	N.S.	N.S.	r = .261 p = .018	r = .416 p < .001
Group Lab tests	r = .297 p = .008	r = .477 p < .001	N.S.	N.S.	r = .255 p = .021	r = .566 p < .001
Midterm Exam	N.S.	r = .370 p = .001	N.S.	r = .354 p = .001	N.S.	r = .387 p < .001
Final Exam	r = .225 p = .046	r = .580 p < .001	N.S.	N.S.	r = .252 p = .022	r = .351 p = .001
Clicker Quiz	r = .606 p < .001		r = .300 p = .007		r = .316 p = .004	

N.S.: Correlation not statistically significant

Reflections on clicker use in CSE 131

The use of a personal response system in CSE 131 has had a number of tangible benefits. Benefits for CSE 131 students have come in combination with a shift from the standard lecture-before-lab scheduling and to a lecture-after-lab scheduling³.

The strongest benefit has been in student attendance in lecture and attitude during lecture. Attendance ranged in the realm of 60% prior to introduction of the PRS. After introduction, attendance was solidly, and predictably at 80%-85%.

In addition, students are genuinely engaged in lecture sessions with the introduction of the PRS. Part of this heightened engagement can be understood based on necessity: students have to stay

tuned in to the lecture to garner the points available from the “clicker quiz” questions that may pop up at any time.

CE 221

The Department of Civil and Environmental Engineering at Michigan State University started teaching Statics (CE 221) in fall 2004, prior to this the course was taught by the faculty in the Material Science and Mechanics and Mechanical Engineering programs. This is a required, sophomore/junior level course for all students who have declared Mechanical or Civil Engineering as their major. The course is offered in the fall, summer and spring semesters. Typical enrollment ranges from 175 to 225 students in any given semester. The majority of the class is populated by sophomores and juniors interested in pursuing civil or mechanical engineering in their junior and senior years at Michigan State University.

The grades for the course are distributed as follows: (i) 5% for class participation through the use of the personal response system; (ii) 10% for homework assignments; (iii) 50% for in class tests (10% for each quiz; (iv) 15% for in class announced quizzes; and (iv) 20% for the comprehensive final exam. The instruction team includes the lead instructor and 4-5 teaching assistants (TAs). The role of the TAs is to grade the homework assignments, quizzes, tests and final exams and to work with students during the help desk hours. The students have access to the help desk five days during the week for approximately six hours per day. In general, TAs are encouraged to attend lectures and assist the lead instructor during in class problem solving exercises and proctoring tests and exams.

All course lectures are in the form of Power Point Presentations and are uploaded onto the course website. The student version of these lectures follow the same sequence as that of the instructor's version, however, the solutions to the problem sets are not complete. This stimulates the students to think and elicit discussion with the instructor and the immediate neighbor in order to determine the solution.

Lecture Format

A typical 50 minute lecture format is as follows: (i) identifying the learning objectives and resources; (ii) this is followed by a 10-15 minute presentation of key concepts; (iii) a series of concept check questions (multiple choice format-akin to Mazur's Concept Inventory) are posed to the class and the responses are obtained through the PRS. The instantaneous feedback allows the instructor to further reinforce the more difficult concepts; (iv) one or two extended problems are presented in a scaffolded format so as to break down the application of key concepts. This is where the TAs and instructor walk around in the class room and work with the students; and (v) the lecture ends with a wrap up and things to do for the next meeting. This lecture format tends to keep the majority of the students engaged during the class.

Examples of Concept Questions

This section provides a few examples of the concept questions, the distribution of the responses received during class through the PRS and the post processing of the concept based on the distribution of the responses. The possible answer choices were designed to reflect common misconceptions. Figure 2 shows an example of a typical question

Example 1: Moment of a force about an axis

Which of the following is true?

- (A) $M_x = -60 \text{ N.m}$
- (B) $M_z = -60 \text{ N.m}$
- (C) $M_z = +140 \text{ N.m}$
- (D) $M_y = 0 \text{ N.m}$

The correct answer is choice (D)

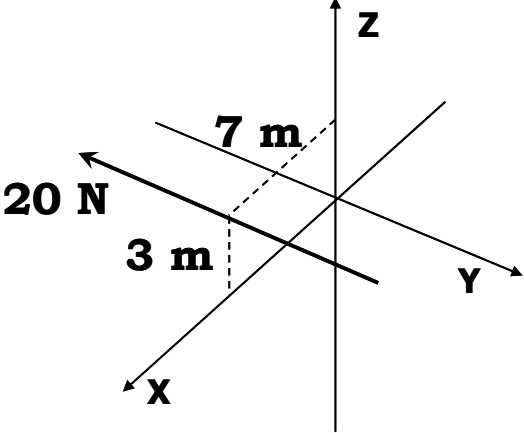

The diagram shows a 3D Cartesian coordinate system with three axes: x, y, and z. The z-axis is vertical, the y-axis is horizontal to the right, and the x-axis is diagonal pointing down and to the left. A force vector of 20 N is shown as a thick arrow pointing in the negative y-direction. The force is applied at a point in the x-z plane. Dashed lines indicate the coordinates of this point: 3 m along the x-axis and 7 m along the z-axis.

Figure 2: Concept Question on Moment of a Force about an Axis

The students are given 60 seconds to respond to this question. Figure 3 summarizes the distribution of the responses obtained through the PRS.

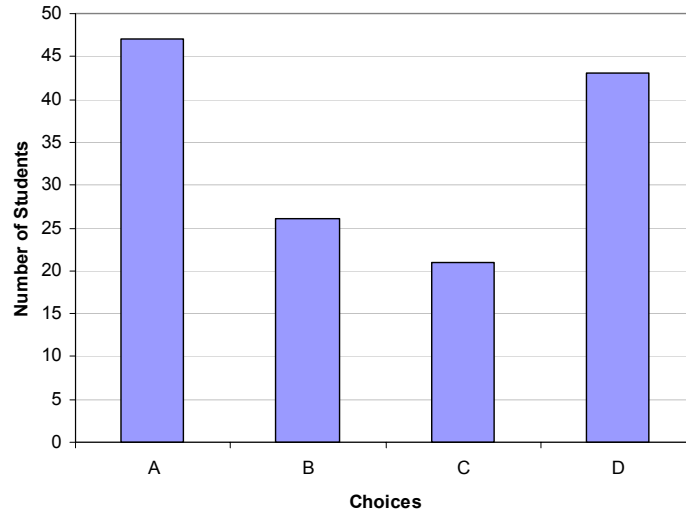

Figure 3: Distribution of responses to the question in Figure 2

The following typical errors are reflected in the responses:

- Ignoring the direction of the 20 N force and focusing only on the magnitude of the moment. Possible reason for the selection of choices (A) or (C).
- Not recognizing the length of the lever arm to the appropriate axis. Possible reason for selecting choice (B).

As a result of the responses summarized in Figure 3, the importance of the “right-hand thumb rule” and the fact that “moment” is a vector quantity were re-emphasized and additional problems were solved in class.

Example 2: Moment of a couple

A couple is applied to a beam as shown. The resulting moment due to the couple force is:

(A) 50 N-m
 (B) 60 N-m
 (C) 80 N-m
 (D) 100 N-m

The correct answer is choice (B)

Figure 4: Moment of a couple

The students are given 60 seconds to respond to this question. Figure 5 summarizes the distribution of the responses obtained through the PRS.

The following typical errors are reflected in the responses:

- a.) Not recognizing the need to resolve the 50 N force in the vertical direction. Possible reason for choice (D).
- b.) Incorrect projection of the 50 N force, i.e. computing the horizontal component. Possible reason for choice (C).

As a result of the responses summarized in Figure 5, the scalar definition of a moment couple was re-emphasized.

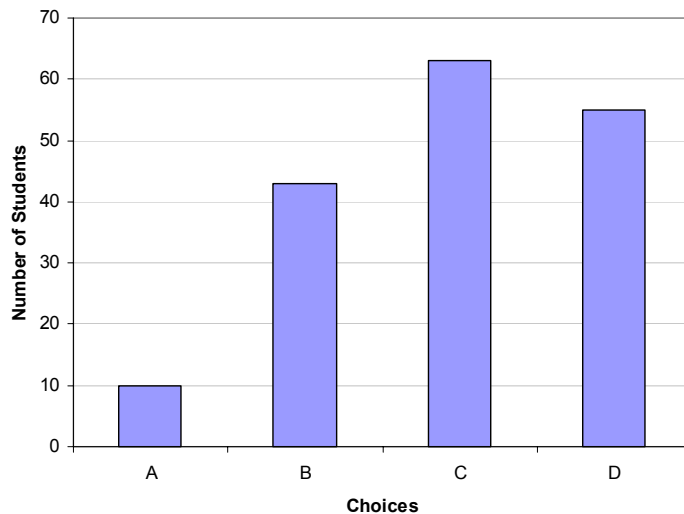

Figure 5: Distribution of answers to question in Figure 4

Example 3-Internal Forces and Frames

The students were given two minutes to sketch the Free Body Diagram (FBD) for the schematic shown in Figure 6. Following this the answer (shown in the lower part of the figure) was projected onto the screen and the students were asked to respond as “YES” or “NO” to whether their sketch matched the answer. Seventy-eight percent of the students responded that their figure matched. The following typical errors are reflected in the responses:

- a.) Incorrectly assuming the value of the force at B.
- b.) Overlooking to make force interactions between two members equal and opposite; for example at pin location B.

Sketch the free body diagram (FBD) for members AB and BC.

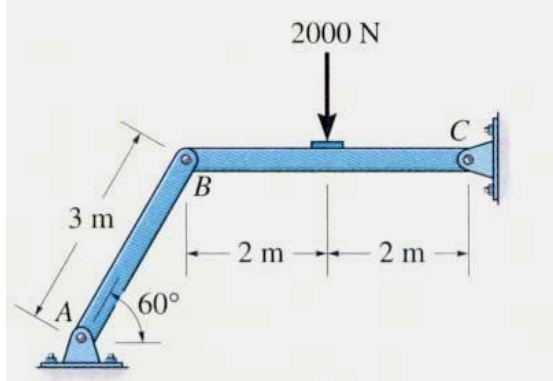

The appropriate FBD is:

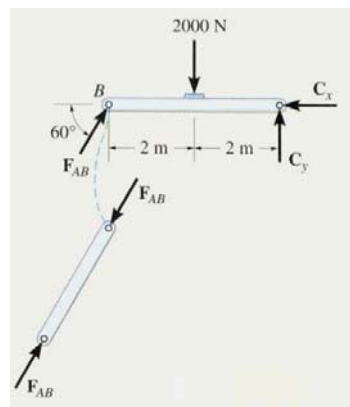

Figure 6: Free Body Diagram problem

Results in CE 221

Students received 5% participation points for answering the clicker questions. Attendance and use of the PRS was not normally distributed. The median attendance for the class was 89.5% of the classes, with 25% of the students attending over 96% of the classes and 75% of the students attending over 75% of the classes. Because attendance was not normally distributed, the rank of attendance was computed for the analyses.

Although students were not graded on the correctness of their answers to the PRS questions, the software stored their responses and we were able to analyze the correct responses. The responses

were normally distributed (mean = 63.75% correct; standard deviation = 14.01%) across all students for the 57 PRS questions asked during the semester.

Attendance correlates with each of the outcomes in each of the components of the course. Attendance correlates with correct clicker responses ($r = .191, p = .005$), even though there were no points awarded for getting the answer correct. Attendance also correlates with homework scores ($r = .447, p < .001$), quiz scores ($r = .418, p < .001$), test scores ($r = .287, p < .001$), and the final exam ($r = .401, p < .001$).

The correlations between the percent of correct PRS responses and the scores on the various course components are similar to the attendance outcomes: the correlation with homework is somewhat less ($r = .374, p < .001$) as is the correlation with quiz scores ($r = .369, p < .001$). However the correlations with test scores ($r = .358, p < .001$) and the final exam ($r = .268, p < .001$) are a little higher than the correlations between attendance and those scores. It appears that what is crucial is attending class and participating, rather than the students' actual answers to the PRS questions.

We divided the students into low, middle and high abilities based on GPA as we did for the CSE 131 students. For these students, GPA again is strong predictor of course outcome ($r = .719, p < .001$). However, the number of students from whom we had consent to obtain GPA resulted in small groups. There were no differences between groups on attendance. The distribution of Total Points earned in the course and GPA for each group is shown in Table 3.

Table 3: CE 221 Distribution of Total Points and GPA by GPA group

Percentile Group based on GPA	Variable	Mean	Std. Deviation
Low N = 35	Total Points	75.04	7.26
	GPA	2.73	.30
Middle N = 36	Total Points	83.20	4.78
	GPA	3.26	.09
High N = 36	Total Points	88.48	3.03
	GPA	3.70	.17

We examined the relationships between attendance and performance in each group. However, due to the small sample sizes in each of these groups, the correlations between attendance and performance outcomes, while positive, are not statistically significant.

We examined the correlations between correct responses on the PRS questions and performance in each group. As in CSE 131, the positive relationship is strongest for the low and high GPA groups, but there is no relationship between correct PRS responses and performance for the middle GPA group. In the low GPA group, correct PRS responses are positively correlated with total points ($r = .382, p = .024$) and test scores ($r = .386, p = .022$) but there are no significant correlations between correct PRS answers and other scores. In the high GPA group, there are

similar relationships. Correct PRS responses are positively correlated with total points ($r = .369$, $p = .027$) and test scores ($r = .432$, $p = .008$) but there are no significant correlations between correct PRS answers and other scores.

Reflections on clicker use in CE 221

Although students only received a small amount of credit for participating in the PRS questions and were not evaluated on the correctness of their answers, most students chose to attend class and attendance was consistent across GPA groups. When the entire class data is analyzed, attendance and participation predicts grades as well as the correctness of the students' answers. Given that the instructor used the PRS questions primarily for formative feedback to the students and as a diagnostic aide for instructional purposes, these results are to be expected. However, students engagement with the content and reflection upon it seems to have a positive impact on their performance in the course.

Use of the PRS seem to have a positive impact on attendance. Since the course was previously taught by different faculty in a different department, it is somewhat difficult to compare the current attendance. However, the previous instructor estimates that attendance in the course when he taught it would average 70 – 75% for non-exam class days. The current class median attendance is almost 90%.

As in CSE 131, it appears that the use of the clickers has a non-linear relationship with student outcomes based on student GPA. High GPA students and low GPA students both seem to benefit from the use of the PRS, while middle GPA students do not seem to display a similar improvement.

Conclusion

Although both instructors used PRS questions extensively in each of their courses, their approaches were somewhat different. In CSE 131, the instructor used a high stake approach to encourage students to come to class prepared. Half of the questions were used to test student recall of the readings. The other half of the questions was used to test students' synthesis abilities. In CE 221, the questions were more conceptual and formative in nature, used to help the instructor understand student misconceptions.

In both classes, student participation and engagement with the PRS questions was positively related to outcomes. While students who answered the PRS questions correctly did well in other parts of the courses, the act of engagement alone, not just correct answers, appears to account for student outcomes. This is true for both courses, even though they awarded dramatically different amounts of credit to the students for their participation. Both approaches appear to improve student attendance and engagement.

The other outcome that appears to be consistent across the courses is that the PRS seems to be particularly helpful to the lower GPA students who may be at risk. The effect is stronger in CSE

131 than in CE 221, but it is difficult to say why. One reason may be due to the smaller numbers of students in the three groups in CE 221. Another reason may be that the CE 221 students are somewhat older (second and third year students) compared with CSE 131 which is mainly first and second year students. The GPAs for CE 221 (mean = 3.23, standard deviation = .44) are higher than in CSE 131 (mean = 2.95, standard deviation = .65). This is likely due to admission practices in the MSU college of Engineering where students are not admitted to the college until their junior year. Since the CE 221 students are further along in their programs, more of them have already been admitted (based, in part, on GPA) and there will be fewer lower GPA students since they were not admitted. However, these results suggest that students who are more at-risk academically, may benefit from the active learning and frequent formative feedback provided by the PRS.

Finally, utilizing the PRS to advantage requires a rethinking of lecture style and design. Although for some time, it's been clear that lecture sections should be designed to follow a pattern with 15-20 minute modules¹¹, the use of the clickers in class demands that a pattern of lecture punctuated by clicker questions be followed. Moreover, development of effective clicker questions for use in lecture requires that instructors try to think through the misconceptions that students may have. Ultimately, feedback from clicker questions enables an instructor to tailor a lecture in real time to address student misconceptions.

Bibliography

1. Bransford JD, Brown AL, Cocking RR, editors. How people learn: Brain, mind, experience and school. Washington, DC: National Academy Press; 1999. 319 p.
2. Mazur E. Peer instruction: A users' manual. Upper Saddle River, NJ: Prentice Hall; 1996. 253 p.
3. Sticklen J, Urban-Lurain M. Enhancing learning of low ability students in multi-section freshman lecture/laboratory classes. 2006 June 18-21; Chicago, IL. IEEE.
4. Hovell MF, Williams RL, Semb G. Analysis of undergraduates' attendance at class meetings with and without grade-related contingencies: a contrast effect. *Journal of Educational Research* 1979;73:50-53.
5. Jones CH. Interaction of absences and grades in a college course. *The Journal of Psychology* 1984;116:133-136.
6. Levine Jr. The effect of different attendance policies on student attendance and achievement. Boston, MA: ERIC ED 348762; 1992. p 9.
7. Van Blerkom ML. Class attendance in undergraduate courses. *The Journal of Psychology* 1992;126(5):487-494.
8. Gunn KP. A correlation between attendance and grades in a first-year psychology class. *Canadian Psychology* 1993;34(2):201-202.
9. Urban-Lurain M, Weinshank DJ. Attendance and outcomes in a large, collaborative learning, performance assessment course. 2000 April 27; New Orleans, LA. AERA.
10. Bloom BS, Hastings JT, Madaus GF. Handbook on formative and summative evaluation of student learning. New York: McGraw-Hill Book Company; 1971. 923 p.
11. Smith KA. Cooperative learning and the new paradigm for engineering education. 1999 October 28-29, 1999; Baltimore, MD. p 39-45.