

AC 2007-1527: INFRARED COMMUNICATIONS FOR CONTROLLING A ROBOT

Ahad Nasab, Middle Tennessee State University

SANTOSH KAPARTHI, Middle Tennessee State University

Infrared Communications for Controlling a Robot

Abstract

Remote control is about controlling a robot (or any other electronic device) from a distance, either with or without a wire. Infrared remote control is the best known form of wireless control. It is secure, reliable, easy to operate, economical to establish in a firm or industry, and can travel in high and low temperatures where it is troublesome for humans. Complete IR-receiver modules, are available and can be interfaced with most microcontrollers without many extra components. TV remote controls using RC5 standard code can be used with such modules. The present paper discusses the controlling of a robot using a computer through typical T.V. remote control protocol, which transmits different data for different keys that are in the RC5 code standard. One prominent application of this type of robot is for short distance control in areas where human entry is restricted.

Introduction

Controlling a robot with typical TV remote control is an invaluable tool in teaching many concepts in the design, fabrication, and control logic of an electromechanical system. Preliminary Infrared pulses from computer using the Infrared remote control RC5 protocol can be sent through the transmitter part. Serial communication between the computer and microcontroller AT90S2313 is interfaced by RS-232, by decoding the transmitted coded data different data for different keys are generated. The I.R. modulated data from the computer is received by an I.R. detector and decoder circuit on the robot, consisting of a phototransistor, which in turn converts I.R. pulses into electric pulses. The converted data is decoded by using a decoder circuit that consists of a microcontroller. The data from this section is used to control the robot. The data from the decoder circuit is given to another microcontroller. According to the software logic, the computer will control the driver section circuit. The microcontrollers in the system complete the main components of the robot. The chassis is completed with a mounted camera on the robot, and streaming video is taken on the computer. Advantages to this system include reduced cost, reduced complexity in hardware, and smaller software parts. Hardware requirements for this project include a computer, in order to interface and program the microcontrollers, a serial cable and power supply.

RS-232 (Protocol)

RS-232 stands for Recommend Standard number 232. It provides serial communication between computer and microcontroller provides full duplex, asynchronous transmission and specifies the line voltages, connection considerations and baud rates. It consists of MAX-232 converter/chip (level shifter) used to connect the microcontroller to an RS-232 compatible device, such as the com port on a computer. It converts the TTL voltages of 0 and +5 (microcontroller) into voltages between -10 volts and +10 volts.

RC5 Remote (IR Protocol)

The actual communication link between the computer and the software protocol is a vital element in each wireless input device. Philips Home Control (formerly known as RCS) meets the Required Coding Standard including the standard coding systems RC5, RC6 and RCMM (multimedia). RC5 is the Philips standard infrared protocol for remote control products. It is designed for multi-usage; this one protocol can meet the software requirements for a variety of remote control product ranges. An RC5 control "word" is made up of 14 bits and is shown in the Figure 1 below. The red bits are level "ON," while blue are "OFF."

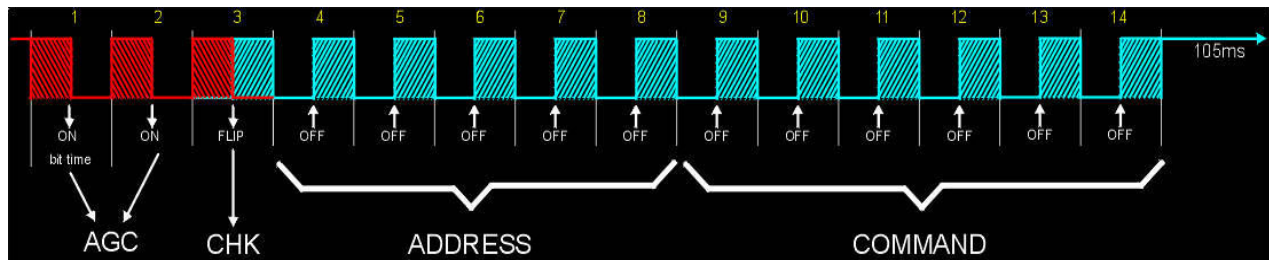

Figure 1: Bit pattern of RC5 Remote

The first two bits, #1 and #2 are called AGC calibration. These are used to "wake up" the receiver and for adjusting the AGC circuit. In the Philips remotes, the bit #3 is the toggle bit, toggles every time you release a button and press another or the same button. The next 5 bits, #4 to #8, are used for system address, or to identify which kind of device should execute the COMMAND bits. For example, TV set uses ADDRESS ZERO, VCRs uses 5. The next 6 bits, #9 to #14, are used for command information to the device selected at the address Bit #14 is the less significant bit, and it is last transmitted. The bit length is approximately 1.8 ms, the code is repeated every 114 ms. To improve noise rejection, the data produced by the encoder chip in the remote is modulated with a 36 kHz carrier.

This project is divided into two main sections hardware and software. The hardware discussion contains details about the microcontrollers, and the software section is about RIDE C compiler and focuses on the firmware written for the microcontrollers. The hardware consists of AT89C51 microcontroller¹, AT90S2313 micro controller, L293D driver, and phototransistor circuit and power supply unit.

The Robot circuit uses an IR receiver chip (Atmel AT90S2313 microcontroller) to receive the IR signal from the computer. The chip includes a band pass filter and a demodulator, making the output a logic signal. An AT89C51 microcontroller controls the signal. The AT89C51 microcontroller feeds the signals to the L293D driver section, which is connected to two small DC motors. Thus the directions of the robot are controlled by the computer. The detailed work of these individual components is shown in Figure 2 below.

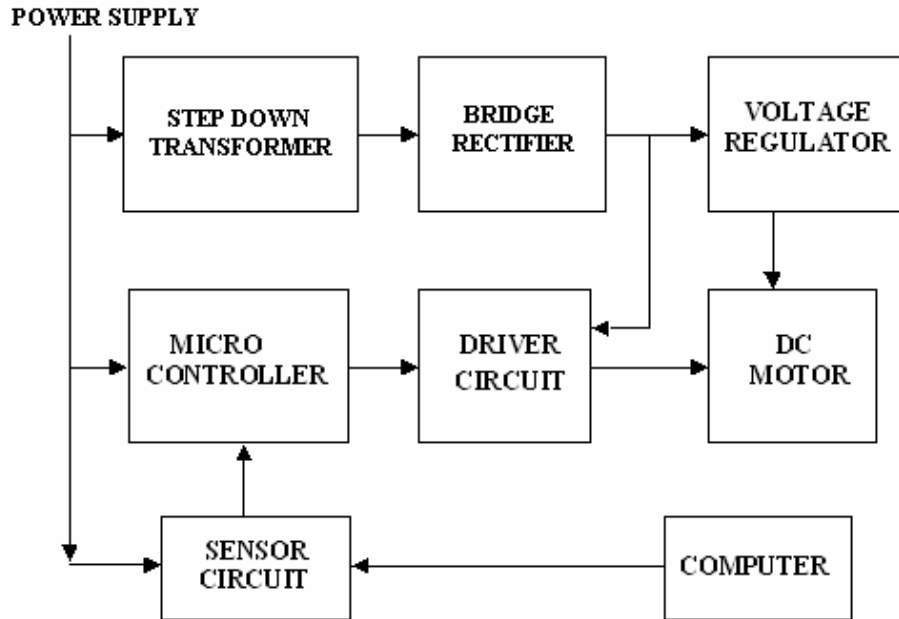

Figure 2: Basic components

Sensor Circuit

The sensor circuit consists of two transceiver sensors, one comparator IC and an AND gate. The output of the transceivers is fed to the comparator IC whose outputs are in turn fed to the AND gate. The output of this logic gate is given to the interrupt pin of the microcontroller, which is an active low pin, In accordance with the code written for the motor the microcontroller reacts on the firing of the interrupt pin-INT0. A 3-pin device receives the infrared burst and gives out the demodulated bit stream at the output pin. The schematic of this circuit is shown in Figure 3.

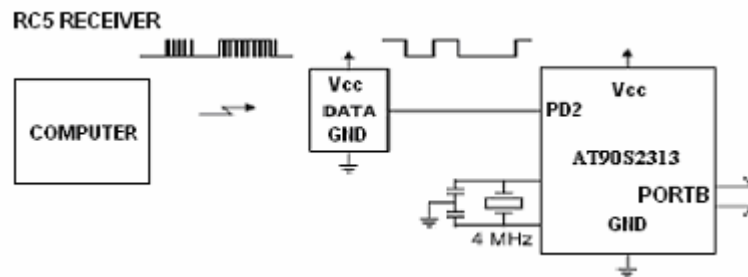

Figure 3: Sensor Transmissions

The AT90S2313 is manufactured using Atmel's high-density non-volatile memory technology. The On-chip In-System Programmable flash allows the program memory to be reprogrammed in-system, through an SPI serial interface. The Atmel AT90S2313 is a powerful tool and provides a highly flexible and cost-effective solution to many embedded control applications. It is a low-power CMOS 8-bit microcontroller, based on AVR RISC Architecture. By executing powerful instructions in a single clock cycle, the AT90S2313 achieves throughputs approaching 1MIPS per MHz allowing the system designer to optimize power consumption versus processing speed.²

Microcontroller

The microcontroller used here is ATMEL 89C51, which belongs to the family of 8051 micro controllers. Its operating voltage is 5V that is provided by external battery. The program instructions control the registers and digital data paths that are contained inside the 89C51, as well as memory locations that are located outside the 89C51. Software instructions generally specify a register by its address, its symbolic name or both.

The serial port of 89C51 is full duplex, meaning that it can transmit and receive simultaneously. It is also receive-buffered, meaning that it can commence reception of a second byte before a previously received byte is read from the register. The serial port receives and transmits registers are both accessed at Special Function Register *SBUF*. Writing to *SBUF* Loads the transmit register, and reading *SBUF* accesses a physically separate receive register.³

Driver Circuit

The driver circuit consists of L293D, an integrated circuit motor driver that can be used for simultaneous, bi-directional control of two small motors. The L293D comes in a standard 16-pin, dual-in line integrated circuit package, with built in fly back diodes to minimize inductive voltage spikes. The L293 is limited to 600 mA, but in reality can only handle much small currents about 200mA. It works on the principle of H-Bridge.

H-Bridge

H-Bridges allow forward and reverse motor control. To get a motor to turn in one direction, simply close an opposing pair of switches. For instance, as shown in Figure 4 by closing the switches A and D motor turn in one direction and the B and C switch close with A and D open, then the motor turns to the opposite direction. To exhibit this action it has to control the switches.

In some cases, 4 transistors will work as the switches or even relays, all of the circuit packaged in a L293D chip. It includes an enable line (turns it all on or off), power lines (for the chip and the motor), switching inputs, and the outputs to drive the motor. Drivers are enabled in pairs, with drivers 1 and 2 enabled by left enable LEN and drivers 3 & 4 enabled by right enable REN. When an enable input is high, the associated drivers are enabled, and their outputs are active and are in phase with their inputs. When the enable input is low, those drivers are disabled, and their outputs are off and in the high-impedance state. With the proper data inputs, each pair of drivers forms a full H-bridge) reversible drive suitable for motor applications.⁴

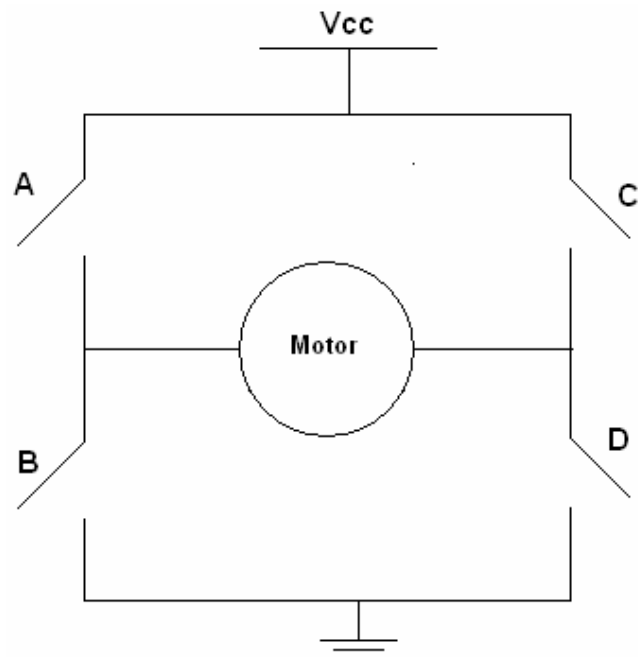

Figure 4: H-Bridge

Software Description

The programming language used here is the ANSI C along with RIDE C compiler. C has become the language of choice for the embedded programmers, because it has the benefit of processor independence, which allows programmer to concentrate on algorithms and applications rather than on the details on the processor architecture.

Overview of RIDE

RIDE is a window based program that allows the user to create projects, call the compiler, assembler, and linker to build the project it simulates and debugs programs efficiently. Running the object-HEX converter converts the linker output file to an Intel HEX file once that has been completed, the HEX file can be downloaded to the target hardware and debugged. The following diagram shows the relationship between this software tools.⁵

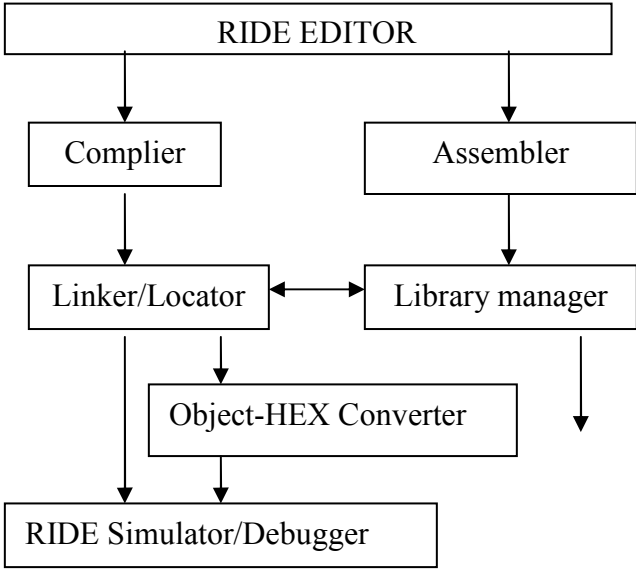

Figure 5: Relationship between the RIDE software

Conclusion

The signal from the computer controls the robot according to the user-specified actions. The RIDE software helps to navigate the robot with user friendly commands. As the hardware and the software of the robot have been discussed, the end users can now control the robot using a personal computer. The video streaming can be viewed in the computer by mounting a camera on the robot .The overall module is shown in Figure 6 below.

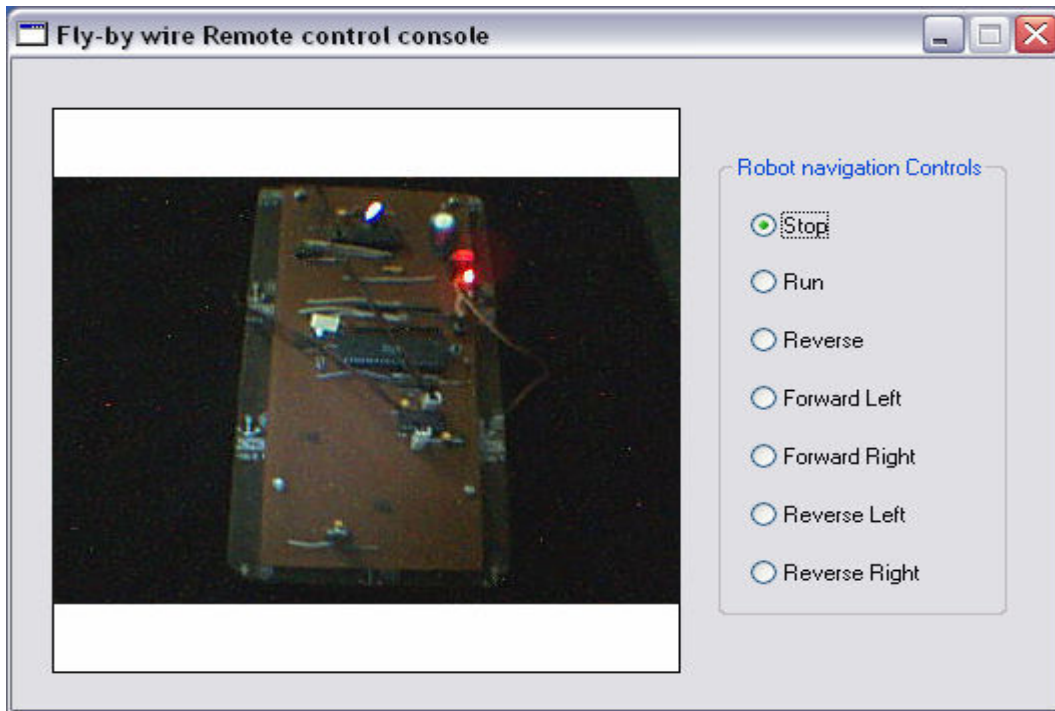

Figure 6: Navigation controls

Thus the overall purpose of this paper has been done most efficiently with low cost and with reduced complexity. The Advantages to this system is to deliver food, water, newspapers, etc. for physically handicapped people. Future enhancement of this paper could be creating some modules to detect distant object and sending signals to the system, using fully automatic control robot can be built with more tasks and can developed.

Reference:

- 1) High speed microcontroller user's guide, Atmel semiconductors
<http://www.atmel.com/products/AVR/>
- 2) High speed microcontroller user's guide, Atmel semiconductors
http://www.atmel.com/dyn/resources/prod_documents/89C52.PDF
- 3) AVR410: RC5 IR Remote Control Receiver, Rev. 1473B–AVR–May-2002
http://www.atmel.com/dyn/resources/prod_documents/DOC1473.PDF
- 4) L293, L293D Quadruple Half-H drivers, SLR S088-SEPT 1986-REV June-2002
- 5) The software compiler used is Raisonance C <http://www.raisonance.com/>