

## **Pathways for Integrating Industry into an Engineering Technology Program**

**Cliff Mirman**

**Chair, Department of Technology, Still Gym 204  
Northern Illinois University, DeKalb, Ill.  
cmirman@niu.edu**

Manufacturing companies need employees that possess both highly technical skills and fundamental knowledge allowing them to continually update skills. Across the country, companies are experiencing labor shortages in skilled areas like robotics, automation, CNC, and welding, for example. As technology progresses, the number of technical graduates cannot keep pace with industrial demand. Educators struggle with three main issues; increasing the pipeline of students into our programs, providing the curriculum needed for tomorrow's technical workforce, and the affordability of technical education with shrinking funding budgets. At Northern Illinois University (NIU), the solution to these and other associated issues is through work with industry as a partner and stakeholder.

The NIU Department of Technology works with industry partners to develop and deliver programs meeting the needs of our stakeholders. Through direct contact, we work with regional companies to attract students and develop laboratories, curriculum, and internships, thus, providing cutting edge technical and problem solving skills needed in today's industry. We work with industry to fund scholarships, and host recruitment fairs for full-time job placement. With industry assistance and funding, students work on faculty/student industry projects and faculty/company directed capstone senior design projects, as a bridge between education and the work environment. Through our Engineer-In-Residence program, Technology graduate students are placed at companies and supported for a semester long "in-house" project. There are many other avenues used to provide pathways between industry and academics.

We have developed a strong triangle which links student, industry, and university. The industry/academic partnership must be present in all phases of development and delivery, providing support, as well as providing pathways to employment.

### **Why develop Industry/Education Partnerships**

Educating students in the areas of Engineering Technology is a complex, costly, and ever-changing undertaking, if it is done properly. As educators, we must provide the students with a skills tool box which includes Mathematics, Science, Communications, and other important topics. Using these basic building blocks, technology programs instruct the students on the applications of theoretical knowledge which can be applied to obtain solutions to many different problems, from electrical circuits, to drainage and storm-water retention, to material composition and deflections, to name just a few. The goal of the Engineering Technology (ET) program is to

produce a graduate who has the ability to apply theory and applications to solve a given problem. To develop this problem solving tool box, the Engineering Technology programs must offer students a strong theoretically-based curriculum, in addition to a strong applications oriented curriculum. The applications in an ET program must instruct the students on the current tools and processes needed to solve industrial problems and implement needed solutions in their particular field of study. Since the Engineering Technology graduate must have a knowledge of current industry process and tools, there is great need for Engineering Technology programs to remain current with the needs of industry. Due to the need for engineering technology to keep pace with the applications and processes used in industry, there is a much greater need for ET programs to maintain appropriate interaction with their regional industry [1,2].

To provide an assessment of the needs within industry from the engineering and engineering technology viewpoints, the author has spent ten years as a faculty member in a mechanical engineering program and twenty years as an administrator of an engineering technology program. In fact, the author has worked extensively with industry in both positions, and, the depth and need of industry involvement within engineering technology is far greater than the industry interaction needs within engineering; much of this is based upon the laboratory and applications needs within the engineering technology fields. In the Electrical Engineering Technology and Manufacturing Engineering Technology programs at NIU, nearly 75% of the course work, in technology courses, includes a laboratory component (either industrial applications or theoretical applications). In the 25% of the courses work without a laboratory component, the students are taught current processes or theories which are used in industry. It should be noted that in nearly all courses students are introduced to levels of theory which are appropriate in the engineering technology areas. Due to the high level of need for both laboratory experiences and hands-on applications, this area of engagement is of major importance, and working with industry on many levels is of great importance in an to the development of the application skills that industry needs.

As was presented earlier, the goals of engineering technology programs should be in-line with the applications needs of the regional industry. Given industry's need to maintain their cutting edge processes and techniques, so to must the engineering technology programs who produce the technical employees who will develop new products, applications, and process for the companies. In education, maintaining current, state-of-the-art laboratory applications for an engineering technology program is very difficult from both the development and cost points of view. At NIU, we maintain current laboratories in areas in which there is much industry need, and we rely on the regional industry to provide many layers of support for their development. Industry needs to understand (and the companies we work with do!) that the assistance that they provide easily comes back to them in the skill-sets which our graduates bring to the job, and the ability of those graduates to perform from day one.

The partnership which must be formed between engineering technology programs (and of course faculty) is important and multi-faceted. At NIU, industry is involved in developing programs, courses, and laboratories. We also include industry in scholarship development and faculty/student projects, as well as internships and post-graduation employment; collaboration with industry is a strong and important part of our program.

### Departmental Financial Needs

The NIU Department of Technology maintains the following laboratory experiences for our Manufacturing and Electrical Engineering Technology programs,

- Computer Design
- Manufacturing Student Projects
- Plastics Technology
- Industrial Safety and Hygiene
- Metal Forming and Joining
- Fluid Power
- Energy and Lighting
- Machining Technology & CNC
- Metrology
- Automation and PLC
- Digital Electronics and Communications
- Power Electronics/Controls
- Electrical Student Projects
- Electronics

In each laboratory, the Department has the goal of educating the program students with the skill sets that they will need to successfully enter the workforce and meet the technical needs of the company for which they work. To this extent, all labs must be current and include equipment that the students may experience in industry. At the start of the year, the Department is given a \$50,000 university budget for equipment and materials for the year; of which approximately \$30,000 is spent solely on laboratory materials. Thus, of the Departmental budget, \$20,000 can be used for equipment – in all labs. Figure 1 shows the breakdown of support to the university between student tuition and state appropriations. As the amount of support from the state decreases, the student tuition increases, and thus, each year, students pay higher tuition.

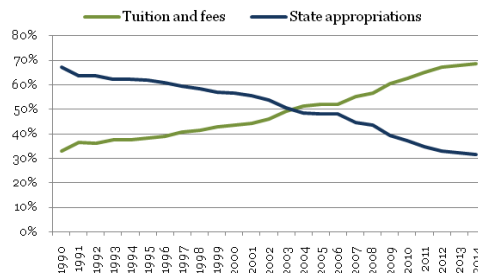

Figure 1 – Student tuition and State appropriations

From Figure 2, one can see that the average student debt incurred from a four-year education is increasing and it is at a very high amount. The combination of Figures 1 and 2 lead one to

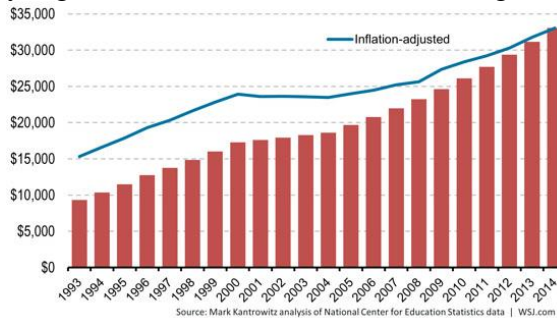

Figure #2 – Average student debt in years graduating class

conclude that if current university education costs increase much more, the average student will not be able to repay student debt. Thus, the university cannot keep increasing tuition costs and departments cannot increase student fees to obtain additional funding for laboratory materials or development. In order to obtain needed funding to enhance or develop laboratories, new modes of support must be found. In addition, in order to assist students in funding the ever increasing costs of technical education, new sources of funding must be found. Figure 3 shows the unemployment rate for individuals in the manufacturing sector.

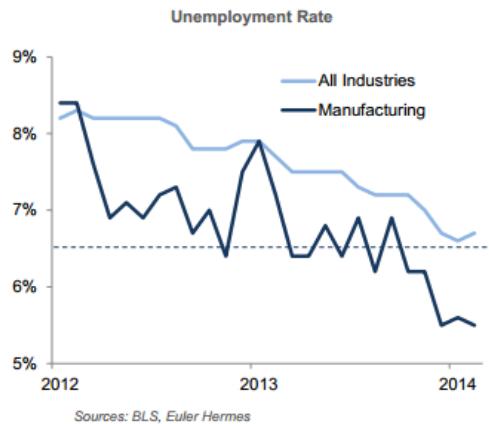

Figure 3 - Unemployment rate within the U.S. manufacturing sector.

Based upon figure 3, one can see there is a severe labor shortage within the manufacturing sector. In fact, in focused areas of technology like automation, CNC, and welding, to name a few, there is even more scarcity within the employment pool. Within a 50 mile radius of NIU, in the northeastern part of Illinois, there are over 5000 manufacturing companies (both large and small) and all are in need of high tech employees. Each year, a fraction of these companies attend the NIU College of Engineering and Engineering Technology employment fair, and come away disappointed, due to the limited numbers of graduates available for employment. Each year, the college graduates 400 students and over a 1000 are needed, as shown in Figure 3. To alleviate the issues of finding qualified employees, the College and Departments have started to work with companies to both increase the pool of students entering the technical programs and to assist in developing the needed skills. The following outlines some of the mechanisms used to work with industry to benefit the NIU programs and students.

### Student Support

To provide students for full- and part-time employment opportunities needed by our industry partners in the region, there is a need to increase the number of students entering the engineering technology and technology programs in the Department. Increasing student numbers in technical areas can be done through the high school matriculation or community college transfer processes. The NIU Department of Technology and College of Engineering and Engineering Technology works with many of the regional high schools as a pathway for students to enter the program. The Department has pathways with many of the community colleges in the state to provide students to transfer into the program. However, based upon the discussion of the previous section, even though students matriculate into the college or department at NIU, the

costs are very high and the debt after graduation is prohibitive. We are seeing higher numbers of students leaving the program due to financial issues. Over the past four years, the Department has been working with our industrial partners and stakeholders to develop company scholarships. Each scholarship is typically expendable, or used in the year it was obtained. Each year, the stakeholders provide about 20 scholarships of \$2000; some of the companies also offer summer internships with the scholarships. In addition to expendable, the department has been actively developing endowed scholarships which will provide student funding into the future. While the scholarship amounts are small, they are appreciated and allow students to reduce their loan burdens.

### **Industry Direction and Feedback**

Technology education must develop skills that encompass both theory and application oriented engagement activities similar to those which students experience in industry. While faculty is keenly focused upon aspects of teaching, they look to industry to provide direction into areas of need from both curriculum and laboratory experience. The skills that industry needs from our technology graduates is constantly changing. To provide assistance in identifying and developing the needed skill sets, the NIU Department of Technology seeks regional industry assistance. The Department maintains three Industrial Advisory Boards (IAB's) which provide feedback on program direction and courses (topics and content) as well as laboratory requirements. The members of the boards assist in developing (and funding) the needed facilities and student knowledge bases required in the manufacturing profession. The board also gives the faculty and chair an indication of how the companies are performing and their hiring needs for full-time and part-time employees at their respective companies. In addition, the board provides information about the new or existing directions in industry which the Department should include or delete from its programs. Many of the advisory board members have requested funding from their companies for laboratory development, student projects, and scholarships. The Departmental advisory boards are also an important method of direct assessment and allow the Department to obtain a level of course and student assessment through direct feedback and interaction with the faculty. Faculty is present during all meetings and a discussion is held as to components of classes and laboratories such that direct information can be shared. In addition, the advisory board shares information on what topics are needed in their industry and company, and how NIU Technology students perform on the job.

### **Industry Projects**

Industry supplied projects are an integral part of the NIU Department of Technology instruction, and are most often found in three areas,

- Capstone senior projects
- Faculty/student projects
- Consulting opportunities for faculty

Working on industrial projects in each area is important and helps student, faculty, and Department, while helping industry solve design issues. In addition, the projects help promote relationships between the Department and the company, while increasing the financial support

from industry. Through project work, the Department has been able to increase our foundation efforts and obtaining funding for lab development and improvements. The following sections detail the scope of sample projects that are undertaken.

#### Capstone senior projects

One of the most important parts of our engineering technology curricula is the year-long capstone project course. This course is modified each year, based upon industry and faculty assessment; currently, the capstone course has the following objectives:

- To provide senior students with an open-ended capstone experience using a subset of skills which have been acquired through major courses
- To provide interaction with industry
- To emphasize interdisciplinary team-work
- To integrate technical, oral, and written presentation skills

Many of the student projects which are completed in the capstone course involve regional industry [3,4]. The projects require rigorous integration of the manufacturing and electronics skills developed in the curriculum.

The capstone course requires students to work in interdisciplinary teams in the completion of an open-ended industrial-type application project. The underlying theme for the course and the projects themselves is the need for a team to develop an iterative problem solving approach, where numerous successful solutions are developed, and the team chooses the optimal. Industry is involved from day one. Initially, faculty meet with representatives of the companies to examine and develop the project into a well-defined undertaking so that students will not go into many different directions and lose focus. The meetings also specify company/team involvement, project deliverables, and the needed funding. Projects are selected based upon the company and the track record of past work (if any), support the company is capable of providing, and components or areas of technology which comprise the proposed project. The projects are also chosen based upon the needed time frame; if the tasks are a priority for the company, they are not suitable for the student teams.

During the first semester of the course, the instructor meets with the students and develops interdisciplinary teams (3-4 students) and assigns each team a project. The team is also assigned a faculty member as project leader, and working with the industry representatives, the team

- Performs background research
- Develops preliminary designs
- Assembles a preliminary budget and timeline
- Develops project proposal

During the second semester of the course, the team works on developing unique develop possible iterative problem solutions, order materials, and assembling a prototype to test. During this work, the team continually consults the faculty advisor and the company representative.

The following three industry sponsored projects detail the mode in which industry capstone projects are selected and completed by the students in the engineering technology programs.

- Sample Capstone Project #1 - Automation of the manufacture of a laboratory mouse enclosure  
When this project was proposed, the company had four individuals assembling mouse enclosures, as shown in Figure 4. The goal of the project was to provide an automated solution to the construction of the three piece top section (Figure 4).



Figure 4 – Image of mouse enclosure and components which comprise enclosure top.

The project was completed by a team of two manufacturing and two electrical students, using pneumatics, sensors, and PLC's to automate the assembly of the entire top section. Figure 5 shows the manufacturing process that the team developed. The separation of each filter from the stack of filters proved difficult, however, the group devised a unique device to perform this task.

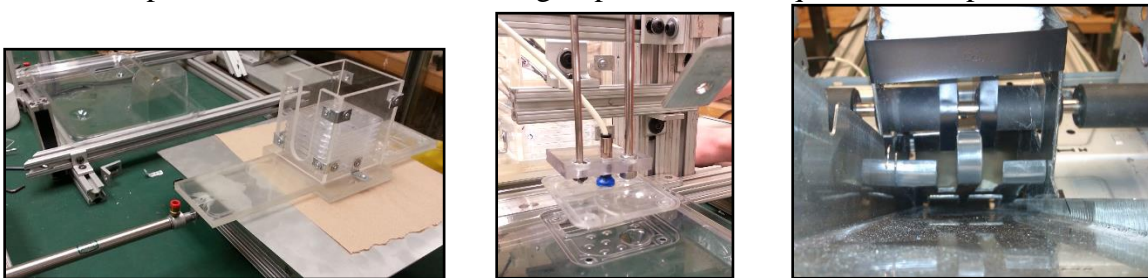

Figure 5 – Insertion of the filter and filter substrate structure to the lid - Sorting of individual filters from stack of filters

- Sample Capstone Project #2 - AC motor end-play analyzer  
Each motor that is produced must be manually tested for the motion (end-play) of the axial shaft which runs the length of the motor (Figure 6); the total amount of motion must be less than 1mm. The manual testing process was very poor and resulted in many shoulder injuries.

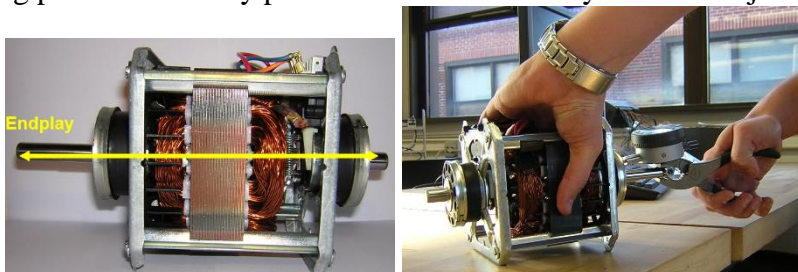

Figure 6 – Motor shaft end-play and manual testing

Figure 7 shows the automated testing device that was developed as part of this project. The device uses a PLC to control the motions of three pneumatic cylinders as well as a digital caliper.

To use the testing device, the operator simply places the motor in the testing area, and presses two start buttons. The pneumatic cylinder secures the motor, and one cylinder pushes the motor shaft to the left. The digital caliper is zeroed through the PLC, and the motor shaft is actuated to the right by the final pneumatic cylinder. The PLC then checks to see if the total motion is less than a maximum value, and either a green (pass) or red (fail) light is lit. This device was welcomed into the manufacturing facility and has been used for many years.

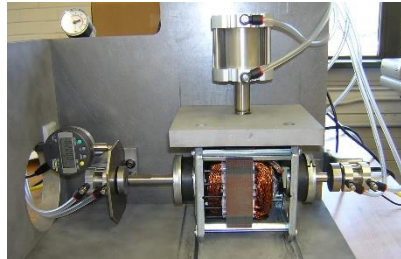

Figure 7 – Pneumatic testing apparatus and testing results.

- Sample Capstone Project #3 - Pump housing and impeller cleaning and pressure testing.

The third sample industrial project involves a group of manufacturing and electrical students working with a company that manufactures water pumps. The first goal of the project was to develop an apparatus which tests the pump housing for leakage; after the pump is assembled (Figure 8). The team designed a system in which the housing is inserted into a base and coupler through a pneumatic actuator; the system was then pressurized and the resulting change in pressure is determined by the PLC controller, thus, detecting leakage. The second goal was to automate the cleaning process for the pump impeller (Figure 9). The team developed an automated device which uses brushes to gently clean cuttings from the fragile impeller vanes after the CNC cutting process. The impeller is brought through 360° of rotation, and all of the foreign particles are removed.

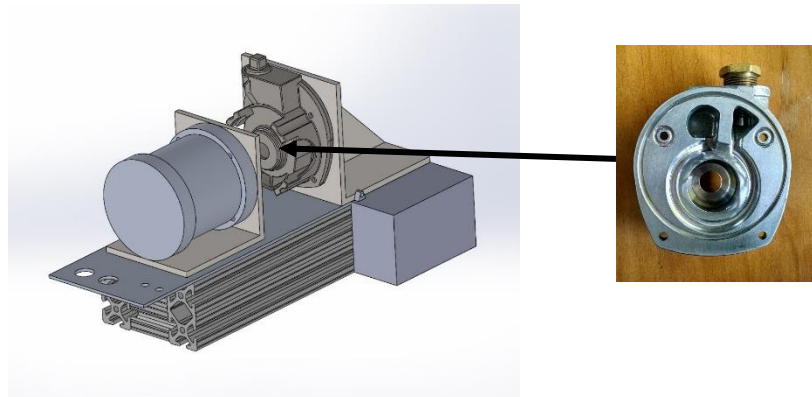

Figure 8 – Pneumatic testing apparatus and testing results.



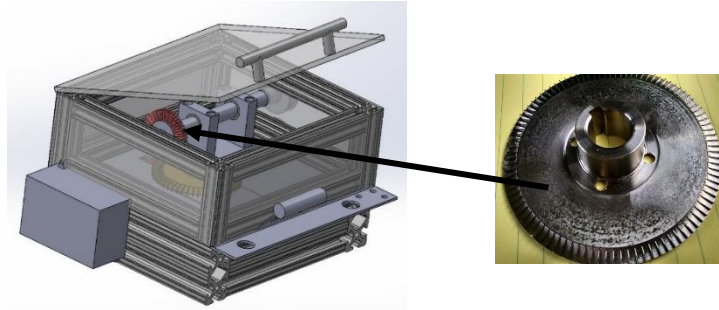

Figure 9 –Impeller surface cleaner

#### Faculty/student projects

Under the over-riding needs of bringing financial assistance to the Department, the faculty has increased submission of proposals to regional companies for student/faculty projects. These projects differ from the typical research projects submitted to NSF or DOE (among others) for research topics; these projects typically result in a specific design or piece of equipment which is needed to satisfy a company's need in a specific area [5,6]. The projects also are outside of a class or internship, and can have a duration from one to four months (typically). The key aspect of this type of project is that there is a student component and the faculty and student (one or more) team work together to complete the project. The company is charged according to time spent by the team, materials needed, and overhead added by the department for space and equipment used. This type of project is good for all parties, faculty, student, department and the company obtains a process or piece of equipment needed for their operations. It should be noted that the student gains much expertise in this type of project due to the closeness of work between them and the faculty; the gains are usually in the depth of knowledge or understanding of new equipment or process that are not typically taught at the undergraduate engineering technology level. The following industry sponsored faculty/student projects detail several of the projects that have undertaken.

- Sample Student/Faculty Project #1 - Rubberized seal quality inspection development

The faculty/student team received funding to develop an automated inspection testing device for rubber/plastic seals. The inspection device used a vision inspection system which was controlled through PLC. The faculty/student team had a three-month time frame where they developed the apparatus, vision parameters, and motion control for the system. Due to the variety of different types of seals tested, the team was required to develop a very robust system. Through this project, the student was employed through the summer, and received valuable instruction in the application of vision and its usage in identifying various types of defects, as well as the application of controls through PLC programming.

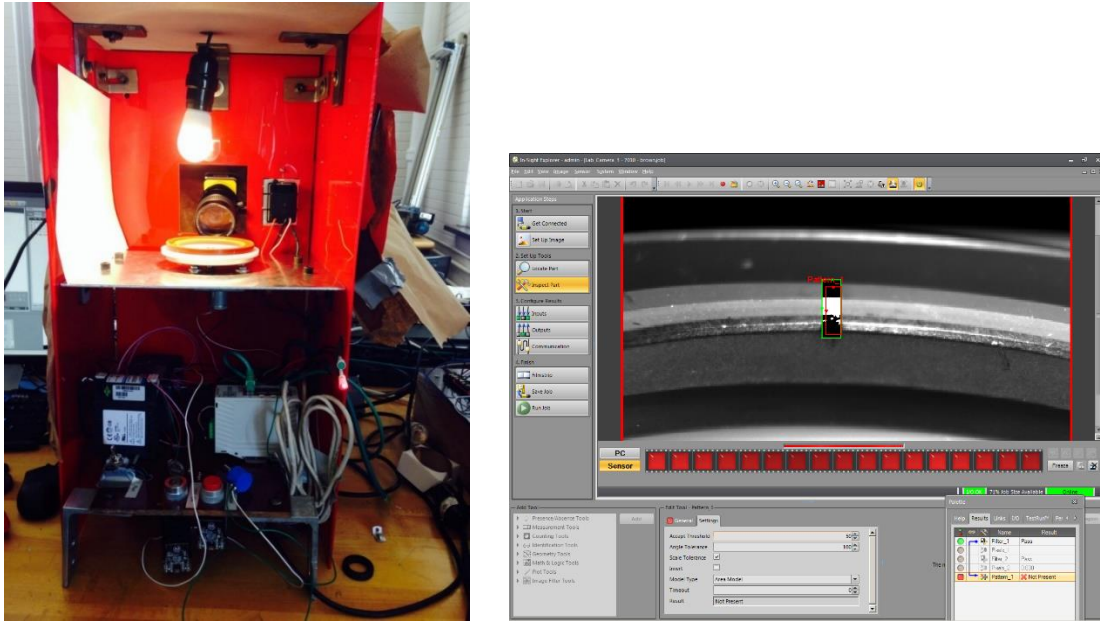

Figure 10 – Apparatus developed to identify defects in seals. Image on the left shows lighting and acquisition (top section) and control aspects (bottom section). Image on the right shows defect as seen through vision system.

- Sample Student/Faculty Project #2 – Automated plastic cup mating machine

A local plastics manufacturing company developed a plastic container which consisted of an inner and outer vessel. At the time of the project, they had contracted with an automation house to develop a machine which mated the two components and locked the inner and out parts in place. However, this device had a lower than 70% effectiveness in locking the two components. A Department of Technology Student/faculty project was developed to simplify the mating process and provide 100% locking. Through this project, the team developed a novel automation track (Figure 11) where the inner cups (from the top track) were joined with the outer cups (lower track). The process was controlled through PLC and required the team to develop novel sprockets to facilitate the proper cup movement in the two tracks and merge into one unit. The locking process was accomplished using a top and bottom roller and was 100% effective. This process is currently in use on ten lines in the company factory.

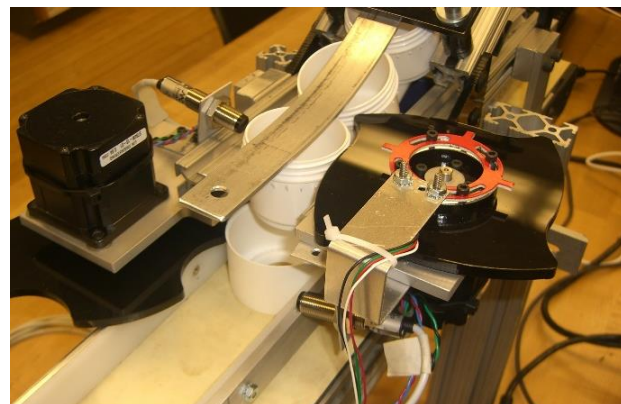
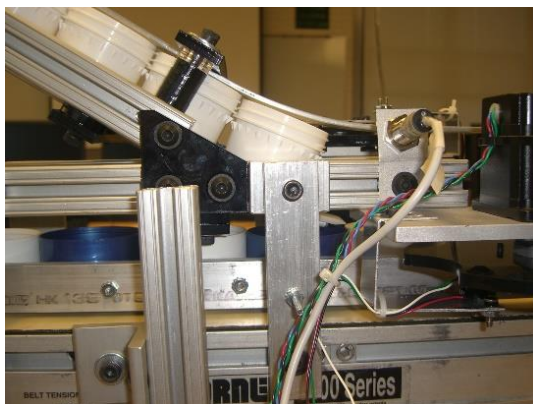

Figure 11 – Apparatus developed to mate and seal plastic cups. Left image shows the inner (top track) and outer cups (lower track) awaiting joining. Image on the right shows the sprockets and sensors that were developed for this operation.

### **Lessons learned in working with industry**

Industry collaboration at many different levels in the curriculum and Department is not a new concept. However, the usage of this concept for both student advancement and the ability to develop a wide range of funding sources within the department is a new concept [7]. The need to acquire funding for the department and its students is becoming a strong requirement at the Departmental level. As the State provide less funding for higher education and students have many competing sources for education, we as educators need to do more to provide top-quality education at competitive cost. We have found that industry projects (at all levels) come with an understanding of completing what is agreed upon at the outset of the project. Working on company projects is not a typical job in the university realm; teaching and developing skill sets in our graduates is a typical expectation of the faculty. Typically, faculty can develop very good and robust designs, however, the needed time-frame for completion, estimating materials, and design iterations is not in the faculty purview. In short, the university, or Technology Departments are not design houses, where they specialize in the completion and optimization of mechanical designs and automation projects. The author has found through his work that many companies understand this limitation, and even want to work around this limitation. The companies understand that they will get a very well thought out initial designs which uses the latest material, equipment, and processes. However, when working with the Department, the final outcome will not be as robust as using a design house, however, the costs are typically far less. This represents values to the companies and allows them to undertake projects that they don't have personal to complete or it gives them another set of ideas for a given issue.

After all of this has been said, it is the project leader who is developing the proposal at the university to bring these limitations to the company representatives. Any issues must be dealt with up front! The issue that the author deals with regularly is the fact that the Department students and faculty are not working for design houses where numerous iterations and deep prior experience is found in the developed project. The companies that the author works with understand this caveat, however, the author learned this under fire! Years ago, we were new to working with companies and proposed a student capstone projects with a regional company for an automated testing device; the company paid \$2000 for parts. The students delivered a testing device, however, the device was not robust to the companies liking (the company was invited to give input during the project, but none was provided) and they threatened a Departmental lawsuit for the project. After this project and another, the author learned, and has developed projects at all levels which specify the deliverables required of all parties at the outset of the project. We have learned for all projects to be successful, companies cannot have the understanding that they will receive a complete “turn-key” system; they will get a very good first iteration, which can be extended. In addition, communication is a must, especially in the case of student projects.

NIU's Engineering Technology program and our students have benefited immensely from company collaborations and they have their challenges. Industry projects are time sensitive and

require working deliverables. From the Departmental point of view, the development of company relationships is a must in developing projects, and many return for additional projects. A good percentage of student projects are usually not fully functional and may either require more time or technical resources that universities do not have. For these reasons, collaborations between industry and universities on student projects often require prolonged and detailed negotiations and this may affect when the project commences, hence completion time. It should also be noted that good relationships with companies through successful (or even relatively successful) projects can lead to additional opportunities with the company, including follow-up projects, faculty delivered short-courses and possible faculty consulting opportunities.

## Conclusion

NIU's department of Technology has developed partnerships and collaborations with companies for many years. What started with a single student capstone project with one company has progressed to working with many companies on capstone projects, faculty/student projects, and even companies providing scholarships and funding for laboratory improvement. In most cases, the desire to foster these relationships is as strong from the company's standpoint as it is from the Department's. Partnerships have benefited our students in gaining visibility and access to employment in the region and having valuable opportunities to work on a real-life, open-ended industry design problems. In addition, through the funding of student scholarships, students are obtaining needed funding for their education from our industry partners. From the department's point of view, the industry relationships bring needed funding to the department for equipment and materials, as well as extra compensation to the faculty who work on these types of projects. From the company's perspective, the interaction with the department brings connections to our graduates. The employment rate in the needed technical areas is very low, and thus, companies can have an in-road into hiring our graduates. In addition, through the projects, companies get insight into new technologies and process which are used to solve their problems. This interaction is an important part of the NIU Department of Technology operations and we have developed great relationships with many of the regional companies. This avenue between NIU and industry is expanding in the types of projects undertaken and the numbers of companies with whom we work. Through industry interaction all parties win!

## References

1. Fornaro, R.J., Heil, M.R, and Alan L. Tharp, A. L., 2006, "Reflections on 10 years of sponsored senior design projects: Students win-clients win!," *The Journal of Systems and Software* 80 (2007) 1209–1216.
2. Kornecki, A.J., Khajenoori, S., Gluch, D., Kameli, N., 2003. "On a partnership between software industry and academia." *Proc. of the 16th Conference on Software Engineering Education and Training*, Madrid, Spain, pp. 60–69.
3. Otieno, A. and Mirman, C., 2003, "Engineering Technology Capstone Experience: An Industry Based Partnership," *Proc. CIEC 2003 Conference*, January 28 – 31, Tucson, Arizona, Session Number 9041.
4. Shin, Y.S, Lee , K.W., Ahn, J.S. and Jung, J.W., 2013, "Development of Internship & Capstone Design Integrated Program for University-Industry Collaboration," *Procedia - Social and Behavioral Sciences*, 102, 386 – 391.

5. Motoyama, Y., 2013, “Long-term collaboration between university and industry:A case study of nanotechnology development in Japan,” *Technology in Society* 36 (2014) 39–51
6. Becker B, and Gassmann O., 2006, “Corporate Incubators: Industrial R&D and What Universities Can Learn From Them,” *Journal of Technology Transfer*, 31, 469 – 483.
7. Mirman, C.R., Sussman, M., and Deegan, S. Manufacturing Connections: A Technical Degree Completion Program which Promotes Partnerships with Industry and Regional Education Centers in Rural Locations – A Long-Term Case Study, *Proceedings of the 2012 Pascal Conference*, Brest France, June, 2012