



## **Laboratory Development for Electrical Power / Machine Control Course**

### **Dr. Omonowo David Momoh, Indiana University Purdue University, Fort Wayne**

Omonowo (David) Momoh is an Assistant Professor in the Department of Computer, Electrical and Information Technology at Indiana University-Purdue University, Fort Wayne, Indiana. He received his PhD in Electrical Engineering from Prairie View A&M University, Prairie View, Texas. He received the MSc and BSc in Electronics and Electrical Engineering from Obafemi Awolowo University, Ile-Ife, Nigeria. He worked for SIEMENS Nigeria Limited as an Electrical Power Project/Service Engineer from 1994 to 2000. His research interests include Electrical Power System Analysis, Electric Machine Drives, Renewable Energy Technology, and Numerical Techniques in Electromagnetics. He is a senior member of IEEE and a member of ASEE.

Austin Deventer, and Christopher Burns are undergraduates in the department of Computer, Electrical and Information Technology at Indiana University-Purdue University (IPFW), Fort Wayne, Indiana.

**Mr. Austin James Deventer**

**Mr. Nathaniel Ryan Beemer**

# Laboratory Development for Electrical Power & Machine Control Course

## Abstract:

This paper describes the eight laboratory experiments developed for the Electrical Power and Machines (ECET 231) course in the Department of Computer, Electrical, and Information Technology at Indiana University-Purdue University Fort Wayne (IPFW), Indiana. The labs were first used during the Spring Semester of 2011 and have been improved every year since then. A brief description of each of the eight laboratory experiments, their respective objectives and the results obtained by some of the students are discussed in this paper. Student assessments for this course/lab are also presented. The feedback has been very positive and encouraging.

## 1. Introduction

A course in electrical power / electrical machines is again gaining more popularity in electrical engineering technology curriculum due to the critical role energy continues to play in our daily life and the unprecedented quest for more efficient and smart electrical appliances. With the energy and power industry in an evolving state, we are learning that there is a shortage of qualified power engineers especially with the high number of baby boomers reaching the retiring age. The power engineering workforce is becoming undersized in comparison to the growing demand and the legacy of the existing power systems experience needs to be conserved in order to successfully transition into the new era of power technology<sup>1</sup>.

The Computer, Electrical, and Information Technology (CEIT) department at IPFW, offers Electrical Power and Machines (ECET 231) as a core course during each spring semester. It is a four credit-hour course with a three-hour lecture and two-hour laboratory per week. The course is opened to sophomore, junior and senior students. Many of the students taking the course are nontraditional, working-class students. They take advantage of the fact that the course is offered in the evening after daytime work hours. Among the topics covered are electrical power system fundamentals, single-phase and three-phase power systems and measurements, electrical machines and controls (drive systems). The use of these machines in energy conversion processes (generators and motors) is taught. Transformers, induction machines and synchronous machines are covered under AC machines while the DC portion covers separately excited, shunt, series, and compound DC machines. Effective teaching of this course requires the development of appropriate laboratory experiments to show students how to practically implement the theories covered in the classroom.

There were no standard laboratory experiments for the course prior to 2010 when the first author joined the Department. Based on industry and prior teaching experience, he developed, eight laboratory experiments for the course. The labs together with the class notes developed for the course were sent to senior faculty from within and outside IPFW for review. The feedbacks was very positive and encouraging. This paper highlights the laboratory experiments developed for the electrical power / machine control course.

## Laboratory Experiments Description & Contents

The laboratory experiments are to correspond to each or a combination of the topics covered in the class<sup>2</sup>. They are developed with the singular objective of exposing students to real world application of the materials covered in the classroom. Students are divided into lab groups of two or three members and are asked to work as team. Team submit a lab report a week after performing the lab. The labs are divided into three broad categories – AC power measurements (single phase & three-phase), DC Machines, and AC Machines (Transformer & Induction Machines); and are performed in that order. The results obtained by a student group (co-authors) for each of these labs are included in this paper. The following sections of this paper highlight each of the eight laboratory experiments developed.

### Lab 1: Single-Phase Power Measurement

This lab teaches students on how to use a wattmeter to measure active power in a single-phase circuit. It also demonstrates how the wattmeter can be helpful in determining the actual operating power factor in a circuit that consist resistive and reactive loads in the absence of varmeter to measure the reactive power. The objectives of the lab includes:

- i. Learn to use a wattmeter to correctly indicate the active power in a single-phase circuit.
- ii. Learn the correct use of scale factors in the wattmeter
- iii. Learn the difference between ‘line side’ and ‘load side’ connections for potential coils of the wattmeter.

The set-up for the single-phase power measurement is shown in Figure 1a. The current and voltage readings of the ammeter and voltmeter respectively are used to compute the apparent power.

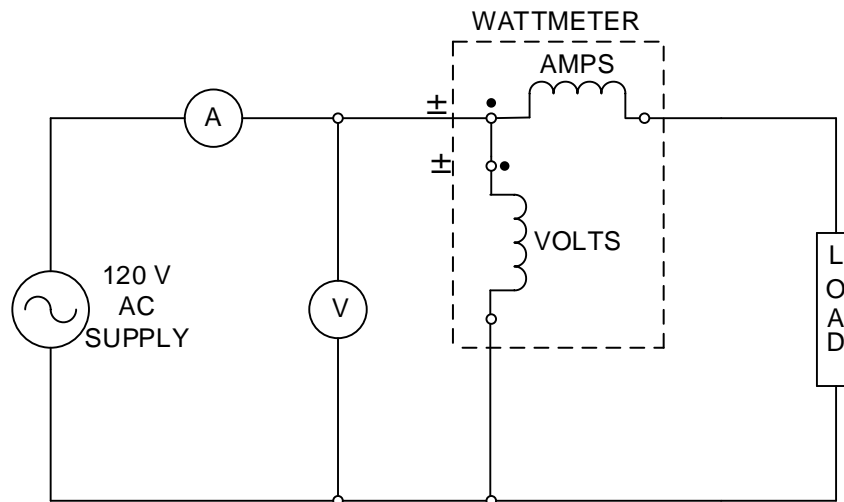

Figure 1a: Single-Phase Power Measurement Circuit

The wattmeter is a multi-range, Hampden<sup>3</sup>, ACWM-100-1, analog model type. The load is a parallel combination of 100 W incandescent lamp, inductive load (Hampden IL-100A model) and capacitive load (Hampden CL-100A model). The students are made aware of the implications of low power factor and how to compensate for low power factor using a capacitor bank. As part of

follow-up questions, students are asked to determine the power factor of a particular circuit set-up, and then draw the Phasor diagram representing the line current and voltage. A sample of a group work showing same is shown in Figure 1b.

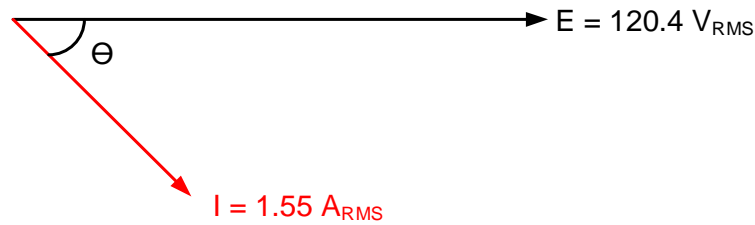

Figure 1b: Phasor Diagram for Single-Phase Circuit

### Lab 2: Three-Phase Power Measurement

The purpose of this lab experiment is to introduce students to the two wattmeter method of measuring power in a three-wire, three-phase circuit. The set-up for the three-phase power measurement is shown in Figure 2a. Three 100 W incandescent lamps are used to represent the resistive loads while a fractional horsepower (1/3 hp) induction motor is used to represent inductive load. The ammeters and voltmeters are also used to determine the apparent power in the three-phase circuit. A Hampden ACWM-100 unit consisting of two-analog-wattmeter is used for this experiment. The students are made aware of the fact that there is no need for a neutral conductor since the three-phase loads are balanced. The effects of unbalanced loads are demonstrated and the importance of having a neutral wire in such a system is explained.

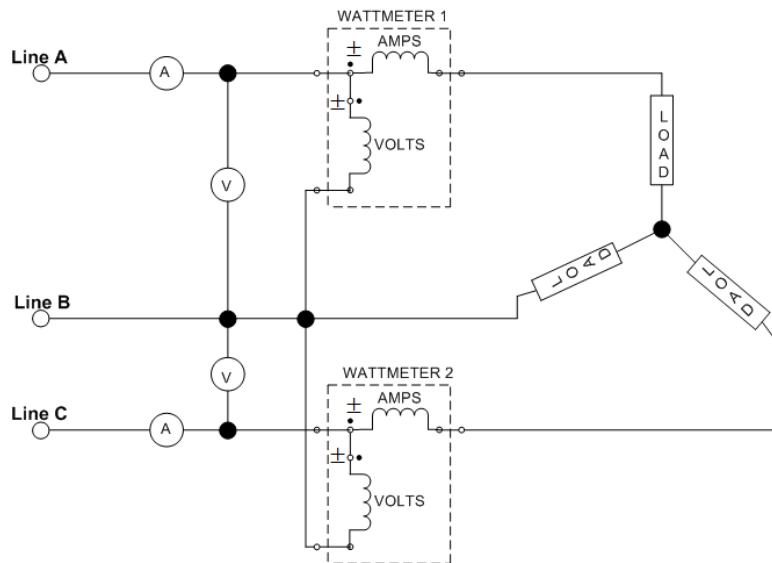

Figure 2a: Three-Phase Power Measurement Circuit

Part of the objectives of this lab is for the students to learn how to calculate power factor in a three-phase circuit based on their measured parameter values. They are also required to be able to draw Phasor diagram representing the voltage and current in each of the three phases and the phase angle between them. Figure 2b shows the result obtained by a lab group. The result shows the line

current, the phase voltage, and the phase angle when the wye-connected, fractional horsepower (1/3 hp), induction motor was connected as load.

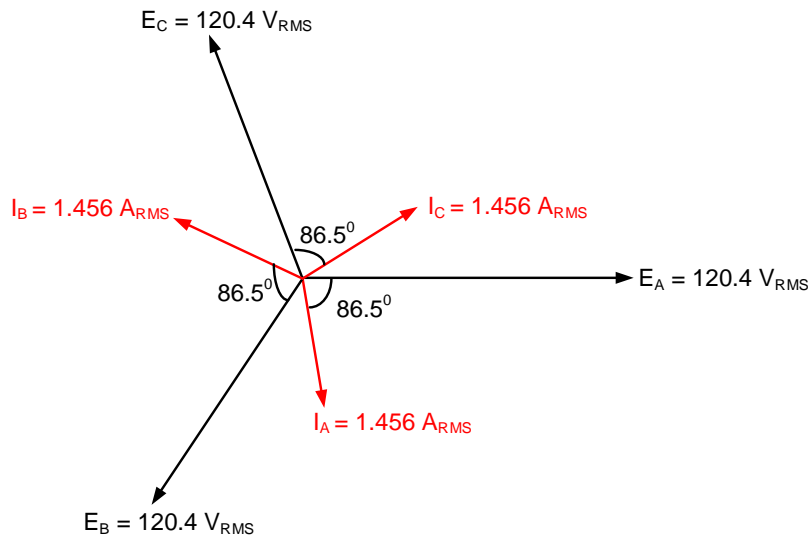

Figure 2b: Phasor Diagram for Three-Phase Circuit

### Lab 3: Determining the Saturation Curve of a DC Generator

The main objective of this lab is to teach students how to determine a no-load saturation curve for a separately excited, fractional horsepower dc generator. Through this lab, students can practically discover how the magnitude of voltage output from the dc generator depends on (1) the armature speed and (2) the magnetic field strength. In order to establish the concept of saturation in the iron core of the machine, a three-phase induction motor (constant speed) is used to drive the generator as shown in Figure 3a.

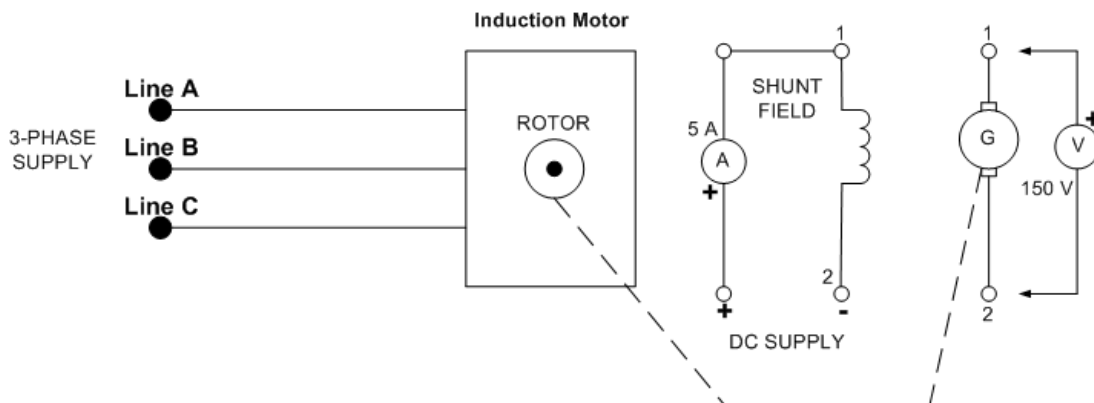

Figure 3a: Separately Excited DC Generator Circuit

By increasing the field current, the magnetic field around the armature is increased. This is done by increasing the dc voltage from the variable dc voltage source from 0 V to 150 V (the highest value), while monitoring the output voltage from the dc generator. Once they have reached the maximum field current, they are asked to start decreasing the field current by decreasing the variable dc voltage from 150 V dc to 0 V in steps. This is done to demonstrate the concepts of

remanence and hysteresis loop. The students are then asked to plot the dc generator output voltage versus the field current for both scenarios. The plot clearly shows the region of saturation. Figure 3b shows the plot obtained by a lab group.

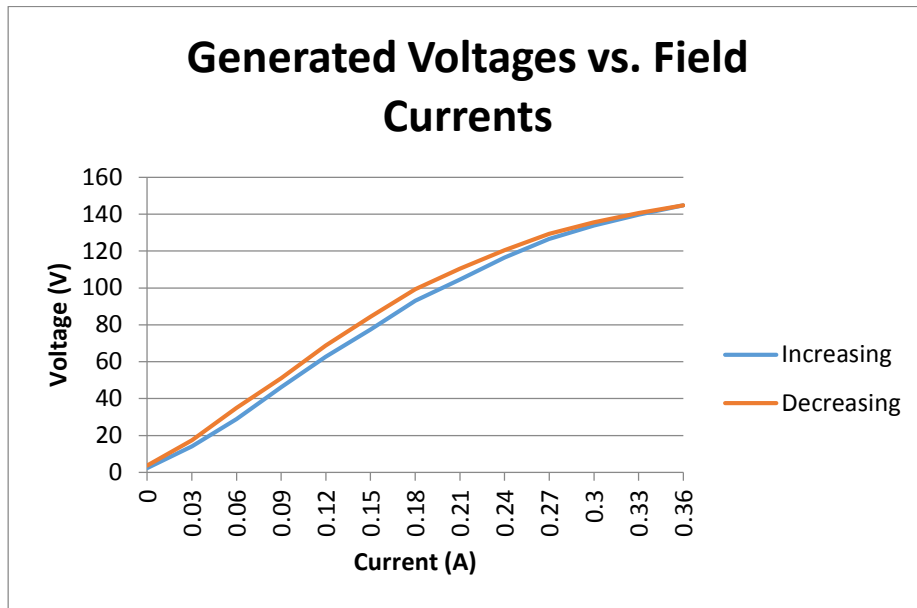

Figure 3b: Saturation Curve of a DC Generator<sup>4</sup>

#### Lab 4: Load Characteristics of a Separately-Excited Shunt Generator

Lab #3 has no load connected to the armature terminals of the dc generator. The objective of Lab 4 is to discover the effect that loading has on the terminal voltage of a separately-excited DC generator at rated speed and rated field excitation. The voltage regulation of the generator is also to be determined. The lab set-up is shown in Figure 4a.

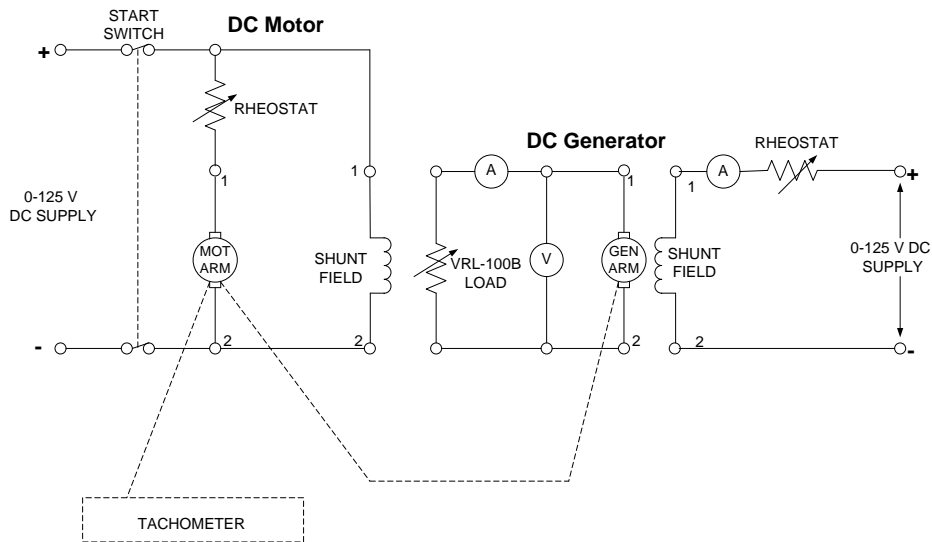

Figure 4a: Separately Excited DC Generator Circuit with Resistive Load at the Output

In this experiment, the speed need to be maintained at the 1725 rpm (generator rated speed), therefore a dc motor is used as the prime mover as against induction motor in lab 3. A Hampden, VRL-100B model, variable resistance load is connected to the armature terminals of the generator. Because both the field strength and speed are constant, there will be no change in the voltage generated, but there will be change in the terminal voltage of the generated due to the current flowing in the armature (load current). The students are required to plot the dc generator output voltage versus the armature (load) current. Figure 4b shows the plot obtained by a lab group.

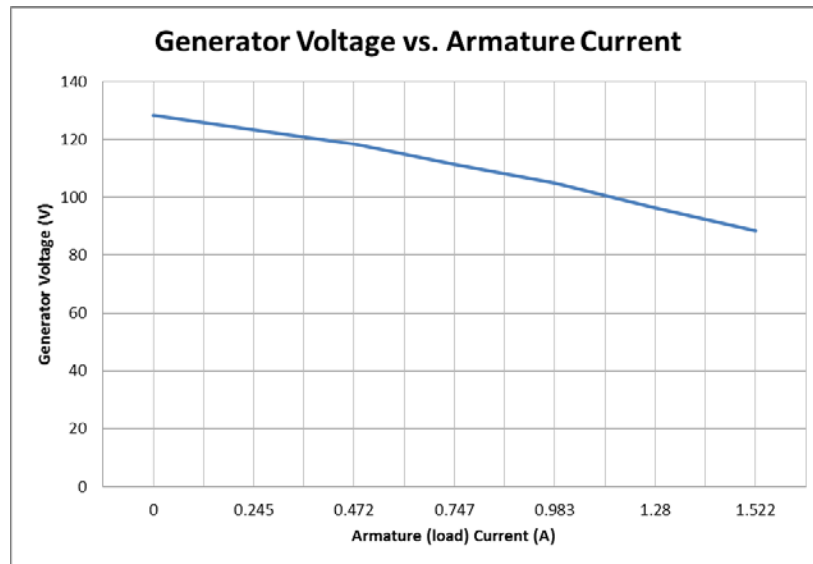

Figure 4b: DC Generator Output Voltage versus Armature (Load) Current.

### Lab 5: Shunt DC Motors

The purpose of this lab is to practically introduce students to the no-load characteristics of DC shunt motors. Figure 5a shows the schematic diagram for the lab set-up. Through this lab, students can practically relate with how the motor rotation is made possible through the interaction of two magnetic fields (field coils and armature coils). The concepts of Lorentz force and Faraday's law of electromagnetic induction as basis for motoring action and electricity generation action respectively are unveiled in these labs. The lab also demonstrates the controllability of the dc shunt motor speed and the direction of rotation by varying the magnitude and the polarity of the field excitation respectively. As part of the lab tasks, students are required to plot the motor speed (rpm) versus the pole field excitation. This is to demonstrate the inverse relationship between the motor speed and the field excitation as expressed in equation<sup>4</sup> (1)

$$n = 1 + \frac{60E_s}{Z\phi} \quad (1)$$

where:

$n$  = speed of rotation (rpm)

$E_s$  = armature voltage (V)

$Z$  = total number of armature conductor.

$\phi$  = effective flux per pole (Wb)

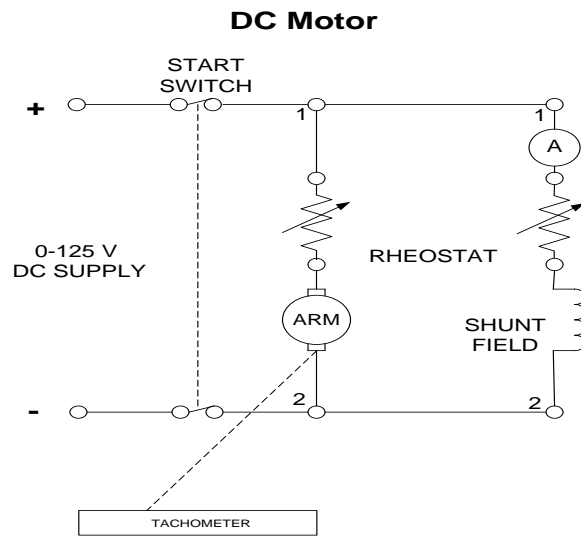

Figure 5a: DC Shunt Motor

Figure 5b shows the plot of motor speed versus the field excitation obtained by a lab group. The inverse relationship between the two can be readily seen on the plot.

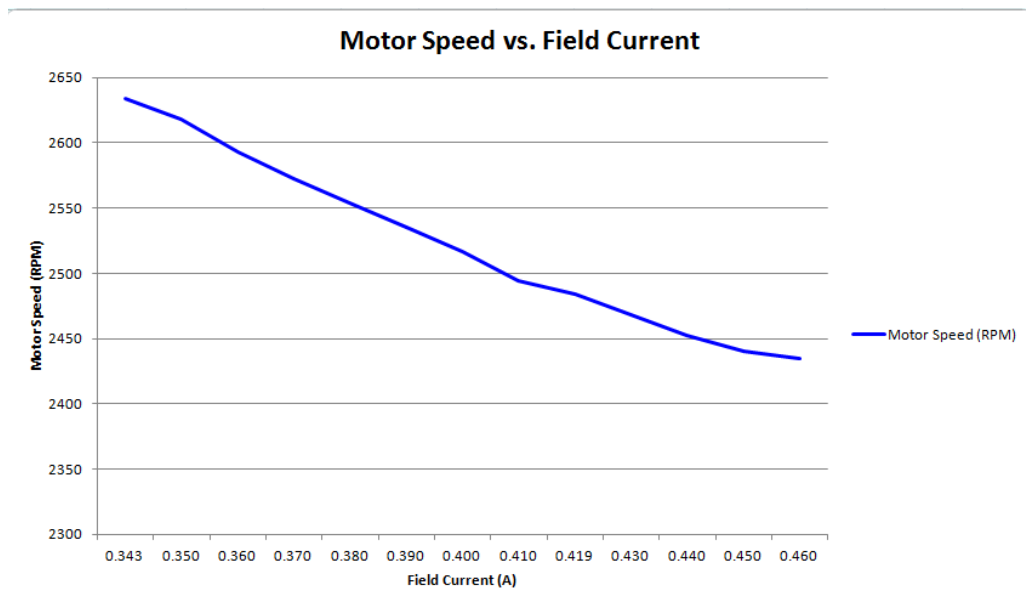

Figure 5b: Plot of DC Shunt Motor Speed vs. Field

### Lab 6: Load Characteristics of DC Shunt Motors

DC Shunt motors are equivalent of AC induction motors in terms of constant speed characteristics; both are widely used for applications requiring constant speed. The change in speed between no-



load and full-load is less for shunt motor than for other types of DC motors<sup>3</sup>. In this lab, students learnt the use of Prony Brake to measure the output torque of fractional horsepower (1/3 hp) dc shunt motor as shown in Figure 6a. The torque is measured in ounce-inch (oz-in) and then converted to Newton meter (Nm).

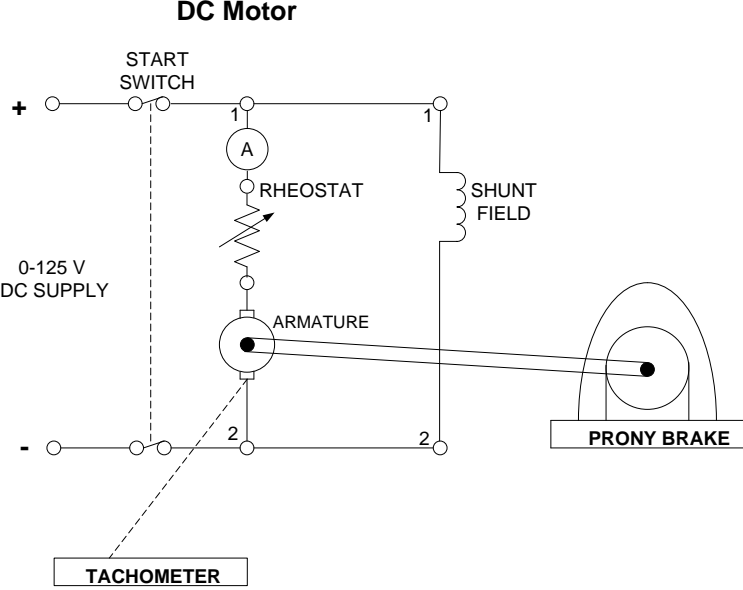

Figure 6a: DC Shunt Motor with a Prony Brake

The lab objectives include the verification of the linear relationship between output torque and the armature (load) current and the field flux as expressed in equation 2. Students are also required to plot the relationship between the motor speed and the output torque. Figure 6b shows the plot of the motor output torque versus load current obtained by a lab group.

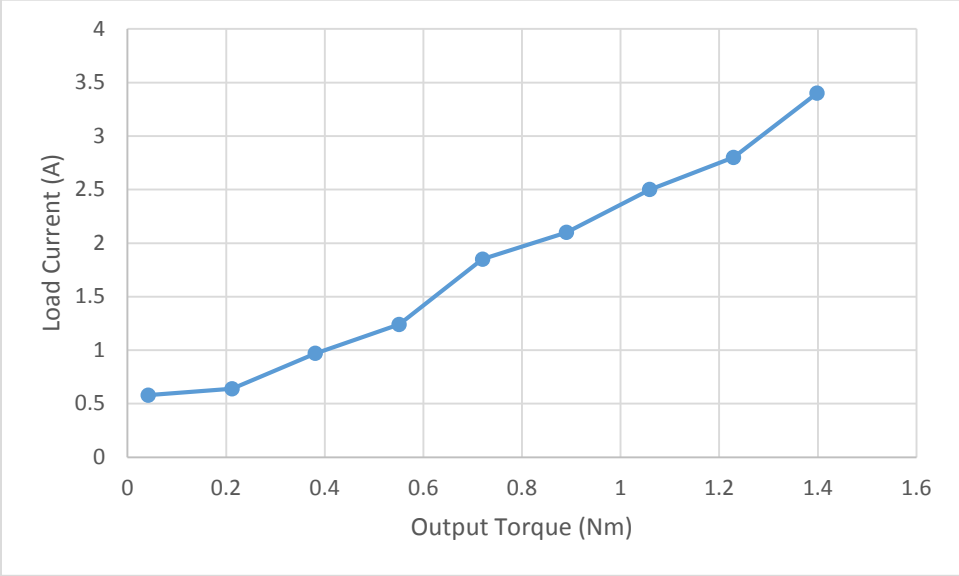

Figure 6b: Plot of Output Torque vs. Load Current

$$T = \frac{Z\phi I}{6.28} \quad (2)$$

where

$T$  = machine output torque (Nm)

$I$  = armature current (A)

$Z$  and  $\phi$  are as described in (1) above.

### Lab 7: Transformer Open-Circuit and Short-Circuit Tests

Information needed for efficiency and performance calculations on transformers can be obtained from two tests performed in the laboratory. These two tests are known as the open-circuit test and the short-circuit test. The objectives of this lab includes:

- Learn to connect and carry out measurements on power transformer
- Determine transformer impedances
- Determine the parameters for the equivalent circuit of a practical power transformer

The schematic diagram for the open-circuit test also known as no-load test is shown in Figure 7a. During the open-circuit test, rated voltage is applied to the primary winding and current  $I_o$ , voltage  $E_p$ , and active Power  $P_m$  are measured. The secondary open-circuit voltage  $E_s$  is also measured.

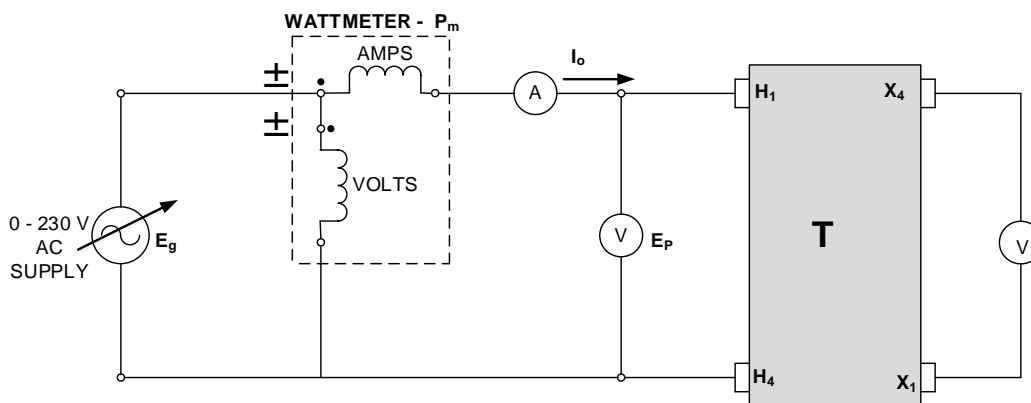

Figure 7a: Transformer Open-Circuit Test

The schematic diagram for the open-circuit test also known as no-load test is shown in Figure 7b. During the short-circuit test, the secondary winding is short-circuited and a voltage  $E_g$  much lower than rated is applied to the primary until the full-load current (rated current) flows in the primary winding. The voltage  $E_{sc}$ , current  $I_{sc}$ , and power  $P_{sc}$  are measured on the primary side.

A two-winding, 1 kVA, power transformer of 115/230 V rating is used in this experiment. The wattmeter is used to measure the active power while the readings of the ammeter and the voltmeter are used to compute the apparent power like in lab #1 and lab #2 above. As follow-up questions to the lab, students are required to determine the following: the core loss resistance,  $R_m$ , magnetizing reactance,  $X_m$ , transformer ratio,  $a$ , magnetizing current,  $I_m$ , iron loss current,  $I_f$ , total

transformer impedance referred to the primary,  $Z_p$ , total transformer resistance referred to the primary,  $R_p$ , and total transformer leakage reactance referred to the primary,  $X_p$ .

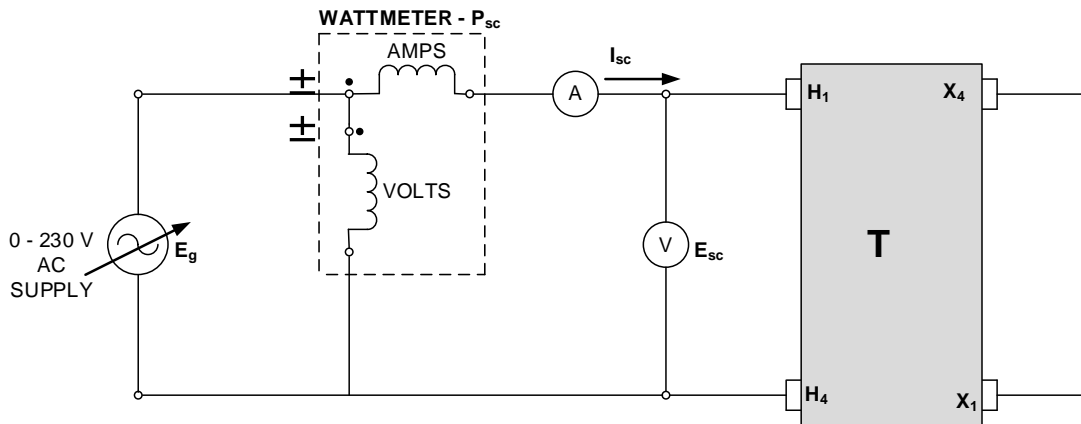

Figure 7b: Transformer Short-Circuit Test

### Lab 8: Speed-Torque Characteristics of Three-Phase Induction Motor

This lab is pretty much like lab #6, except that a three-phase induction motor is used instead of a dc shunt motor. The objectives of this lab includes:

- Become familiar with squirrel-cage induction motor operation.
- Become familiar with using Prony Brake to measure the torque produced by the induction machine
- Determine the speed-torque characteristics of squirrel-cage induction motors.
- Determine the active power consumption of the inductor motor.
- Perform a locked rotor test on the induction motor.

The schematic diagram for the lab set-up is shown in Figure 8a. A three-phase, fractional horsepower (1/3 hp), squirrel cage induction machine is used for this lab. The lab also demonstrate the concept of induction machine as a rotating transformer. Students are required to plot the torque-speed characteristic curve for the machine.

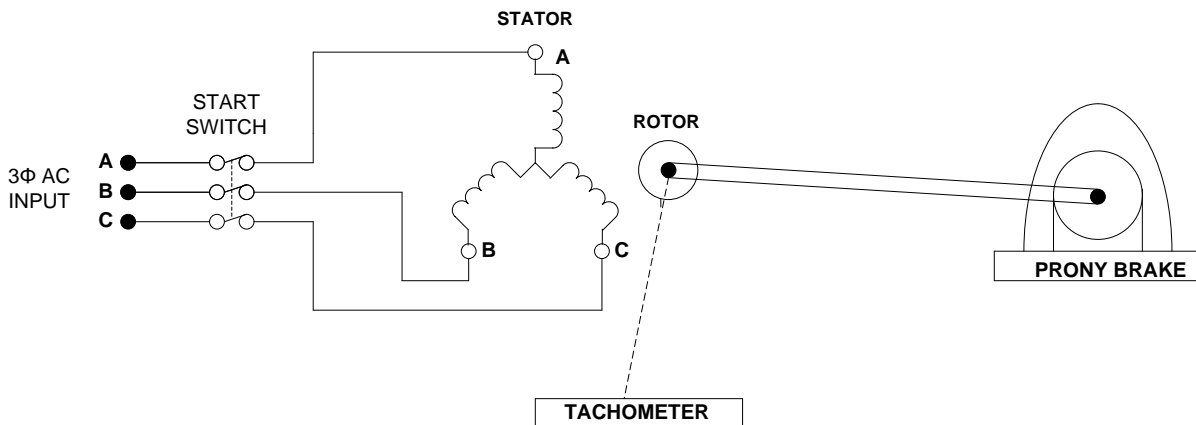

Figure 8a: Induction Motor Torque-Speed Measurement

Figure 8b shows the plot of the motor output torque versus rotor speed obtained by a lab group.

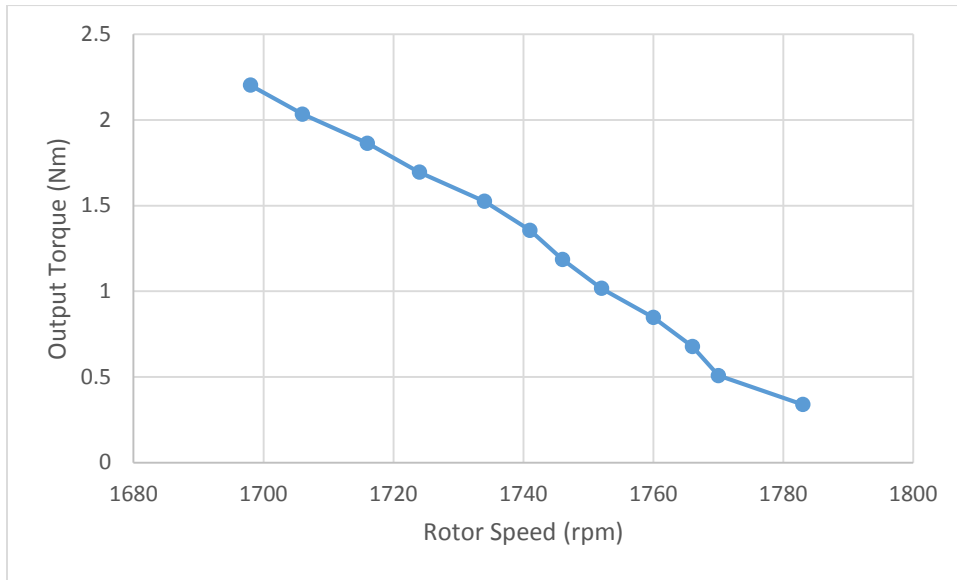

Figure 8b: Plot of Output Torque vs. Rotor Speed

## 2. Course/Lab Assessment

The course has been taught for four years (Spring 2011 – Spring 2014). Students’ feedback and evaluation of the course have been good, and generally, considerably higher than the department average. Table 1 shows a summary of student evaluations for the course<sup>5</sup>.

Table 1

Semester	Student Enrollment	Instructor Overall/ Department Mean	Course Overall/ Department Mean
Spring 2014	12	3.73/3.26	3.64/3.08
Spring 2013	17	3.80/3.32	3.60/3.17
Spring 2012	17	2.75/3.35	2.81/3.17
Spring 2011	13	3.46/3.35	3.08/3.25

Student comments were generally positive<sup>6</sup>. Some of those comments in their unedited form are listed as follows:

- I learnt a lot about transformers.
- I learnt a lot in this course, I have never learnt so much in a class before. I feel like a lot of the info learned I can actually use it in the real world
- The labs were the strong point in this class and I really enjoyed this course because of the materials
- Having had internship without taking the class, this class was an eye opener for many. Had so many questions which were answered.

- It is very hands on and overall everything made sense for the most part.
- The real world application of the labs.
- Very real world oriented.
- The content has a lot of practical applications.
- Practicality of the course.
- Found high power refreshing
- Knowledge of power systems around the world and differences between them.
- Practical, real world application of topics
- The labs were great.
- Lab equipment was 30 years old and 50% of the stuff didn't work. Not enough equipment too.

Generally, the students expressed their satisfaction with the course in its present state and mode of delivery. However, the students would like newer and more modern lab equipment. They also desire to have more lab experiments.

### 3. Conclusion.

This paper describes the development of laboratory experiments for Electrical Power and Machines (ECET 231) course in the Department of Computer, Electrical, and Information Technology at IPFW. The ever increasing importance of energy and the critical role it continues to play serve as the motivation for creating these labs. As a response to students' evaluation for the course and their desire for more labs, two new lab experiments on synchronous machines and brushless dc (BLDC) machine are currently being developed for the course. Overall, based on the student feedbacks and evaluations, the labs can be judged to be successful.

### References:

- [1] W. Shireen, Industry Trends and Power Engineering Education, 120<sup>th</sup> ASEE Annual Conference & Exposition, June 23-26, 2013, Paper ID #7132.
- [2] H. C. Patangia, Laboratory Development for a CCLI Course on PV Engineering, 120<sup>th</sup> ASEE Annual Conference & Exposition, June 23-26, 2013, Paper ID #7381.
- [3] <http://hampden.com/product-details.php?viewid=1025>
- [4] T. Wildi, Electrical Machines, Drives, and Power Systems. Upper Saddle River, NJ: 2006
- [5] O. D. Momoh, Developing a Renewable Energy Technology Course for a Master of Technology (MTECH) Program, 121<sup>st</sup> ASEE Annual Conference & Exposition, June 15-18, 2014, Paper ID #9028.
- [6] M. Rabiee, Using MATLAB to teach Electric Energy Courses, 119<sup>th</sup> ASEE Annual Conference & Exposition, June 10-13, 2012.