

Laboratory Experiments for Enhanced Learning of Electromechanical Devices

Tomislav Bujanovic and Prasanta Ghosh, Senior Member, IEEE

Abstract— In advanced Power Engineering and Smart Grid Laboratory environment students get opportunities to demonstrate their ability to design and conduct experiments, use knowledge of mathematics, science, and engineering to perform complex experiments and learn how to use optimization procedure for accurate data interpretation, and propose additional requirements for the electromechanical devices to meet the application specifications. In this paper we discuss the effects of the strides we have made to improve the pedagogical aspect of teaching in response to changes in the power industry.

Index Terms—discrete Fourier transform, harmonics, least square error, optimization

I. INTRODUCTION AND BACKGROUND

Power industry is poised to adopt multidirectional changes and thus forcing educational institutions to redesign the power engineering with a broad knowledge based curriculum for the future engineers. To train future engineers we need to modernize traditional courses and at the same time introduce new courses that deal with the complex nature of future power delivery system including but not limited to electric power generation, transmission, and distribution, in both (quasi) steady state and transient processes analysis. In addition, development of the smart grid requires wide innovative implementation of the recent advances in control systems, communications, signal processing, and cyber-security area.

At Syracuse University we offer modernized traditional power courses with hands-on experience. In this category, the courses include Introduction to Power Engineering, Power electronics, Electromechanical devices, Power systems, and Power systems protection. We have also developed number of new undergraduate/graduate courses in the smart grid area that include Introduction to smart grid, Sensors & measurements, Distributed generation integration in smart grid, RF communications in smart grid, Advanced measurements in power systems, Control of distributed generation, Cyber-security in smart grid, and Smart grid security, privacy, and economics. The development of Power Engineering curriculum at Syracuse University was supported by US Department of Energy grant DE-FOA-0000152 Multi-institutional curriculum development and delivery to create the

new smart grid workforce. In the Department of Electrical Engineering and Computer Science we have developed smart grid laboratory to support both undergraduate and graduate education and research related to contemporary power engineering. In our smart grid lab we have modern equipment as well as analysis and synthesis tools currently available in power industry. In this lab students conduct different pre-designed experiments and analyze the response characteristics to understand the equipment operational capabilities and limitations. Students use simulation packages to validate the experimental results while at the same time learn through hands-on experiments how various equipment/sensors can be used in the design of power system for steady state, dynamic, and transient conditions as well as for energy consumption reduction, optimization and management.

Electric machines, as motors, convert electrical power input into mechanical output. These motors may be operated solely as generators, but they can also enter in the generating mode when slowing down during the regenerative braking where the power flow is reversed. The same fundamental electromagnetic interaction principles apply to both rotating and linear machines [1]-[3].

There are two designs of DC machines: stator consisting of either permanent magnet or a field winding. Being of low cost and ease of control DC machines are very popular for speed and position control applications [1].

AC induction motors with squirrel-cage rotors are the workhorses of industry because of their low cost and rugged construction. They operate at a nearly constant speed while powered by standard distribution voltage 208 V, 60 HZ. By means of power electronics converters it is possible to vary their speed efficiently, leading to large savings in operational cost. Induction-motor drives can efficiently serve as high power adjustable-speed motor drives in process control industry as well as in electric traction, including hybrid vehicles [1].

For power processing and control of AC drives require more complex electronics thus making the whole system at present more expensive than in DC drives. However, the cost of drive electronics continues to decrease making AC drives to gain market share over DC drives [1].

The power processing units (PPU) for controlling electric machine can be classified into two categories: line-commutated thyristor converters and switch-mode power converters that operate at a high switching frequency, used in the experiments discussed below [4]-[6].

Manuscript received February 14, 2014. This work was supported by the U.S. Department of Energy DE-FOA-0000152

Tomislav Bujanovic is with the EECS Dept., Syracuse University, Syracuse, NY 13244, USA; phone: 315-443-4583; e-mail: tbujanov@syr.edu.

Prasanta Ghosh is with the EECS Dept., Syracuse University, Syracuse, NY 13244, USA; e-mail: pkgghosh@syr.edu.

In this paper we discuss some lab experiments to demonstrate our efforts how to improve the pedagogical aspect of teaching in response to challenges in the power industry. Following the ABET requirements that electrical engineering graduates must demonstrate (a) an ability to apply knowledge of mathematics, science, and engineering, (b) an ability to design and conduct experiments, as well as to analyze and interpret data, and (c) an ability to design a system, component, or process to meet desired needs, we discuss how our undergraduate students' learning enhances through data acquisition, analysis, and interpretation in their laboratory work within the course Electromechanical devices. The hands-on learning helps them build clear understanding of the subject and develop necessary design requirements and adjustments for electromechanical energy conversion process optimization.

The rest of this paper is organized as follows: Section II discusses how students approach to analysis and interpretation of abundant data collected in a DC motor characterization laboratory experiment; Section III provides an induction machine speed control laboratory experiment, in which students develop optimized induction machine design requirements in accordance to its application; purpose and student learning outcomes are presented in the conclusions in Section IV.

II. DC MOTOR CHARACTERIZATION

After rigorous discussion of the theoretical concept, a DC motor equivalent circuit, as shown in Fig. 1, is developed and analyzed in the class. Students then conduct lab experiment discussed next. The following DC motor characterization experiment objectives include: observation of open-loop speed control of a DC motor; calculation of the motor back-emf constant k_E ; measurement and calculation of the electrical parameters R_a and L_a ; and verification of the voltage vs. speed characteristics of the DC motor.

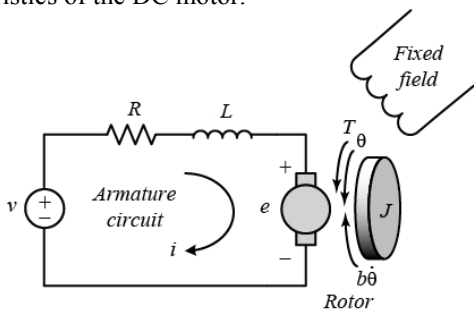

Fig. 1. Permanent magnet DC motor equivalent circuit

A. DC Motor Characterization Experiment

The laboratory equipment used in the experiment include DC regulated power supply, power electronics drive board, 4-channel digital oscilloscope 100 MHz, DC motor 250 W, 42 V_{DC}, and dSpace CP 1104 I/O interface board supported by Matlab Simulink [7] and dSpace [8] programs. Students are asked to determine back-emf constant k_E using the experiment setup shown in Fig.2 and then measure the armature resistance R_a . To determine the armature inductance L_a

students perform the block rotor test using the experiment setup as shown in Fig. 3 and record the armature current and rotor speed data. Examples of the collected data are shown in Figs. 4 and 5 [8].

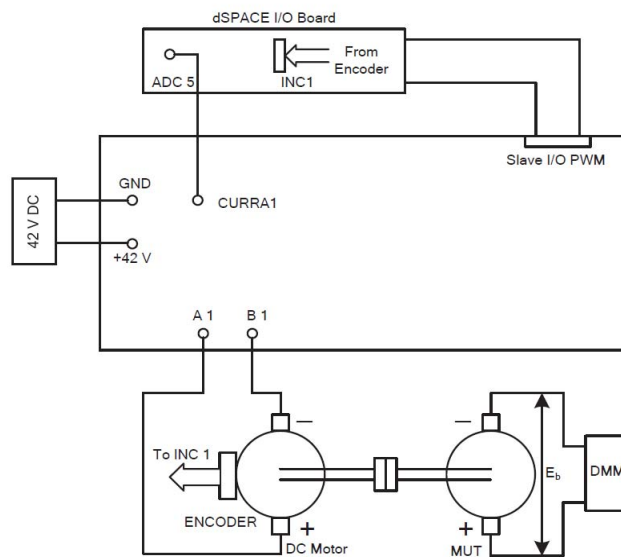

Fig. 2. DC motor experiment setup for measurement of k_E

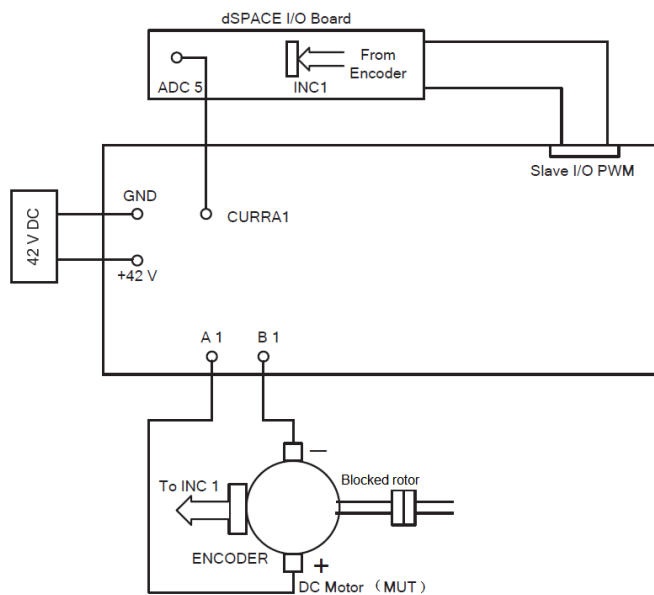

Fig. 3. DC motor experiment setup for measurement of armature inductance

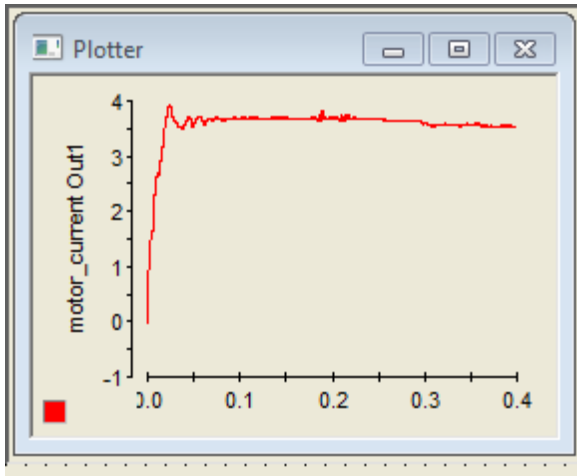

Fig. 4. DC motor under the blocked rotor test recorded current

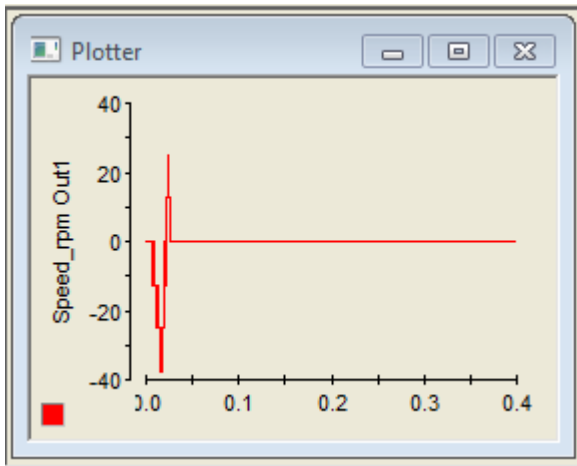

Fig. 5. DC motor the blocked rotor test recorded speed

B. DC Motor Test Data Analysis and Interpretation

Students zoom in the block rotor current vs. time diagram in Fig. 4 and determine the slope at $t = 0$ s, which serves to determine the $R_a L_a$ equivalent circuit time constant $\tau = \frac{L_a}{R_a}$

used in the equation for the step response current

$$i_L(t) = \frac{V_{BR}}{R_a} \left(1 - e^{-\frac{t}{\tau}} \right),$$

where V_{BR} is the applied blocked

rotor step voltage and R_a is the measured armature resistance of the DC motor. Using the calculated time constant, students first estimate the current response as a function of time and compare that with the measured data. Measurements of voltages and currents around $t = 0$ are subject to possible significant relative error and the calculated step response may not match the recorded step response current, as shown in Fig. 6. Considering non-zero speed vs. time of blocked-rotor recorded diagram shown in Fig. 5 and using the digital stream of experimental data students perform least square error optimization procedure to develop more accurate calculated step response current of the DC motor.

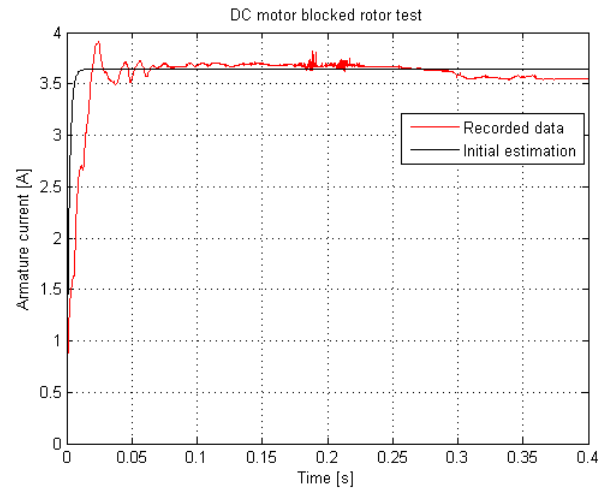

Fig. 6. DC motor blocked rotor recorded step response with initially calculated step response

The result of the optimization exercise matches to the recorded data, significantly increasing the measurement accuracy, as shown in Fig. 7. Similar least square error optimization procedure could be achieved by using Matlab function `lsqcurvefit`. Notice that proper use of the Matlab function requires additional information, which is beyond the scope of this paper.

C. Educational Outcomes

By completing this DC motor experiments, students demonstrate their ability to conduct experiment that requires not only the basic knowledge in electromechanical devices, but also competency to develop the test algorithm using advanced hardware technology environment such as power electronics power-pole switching board and software environment such as Matlab Simulink and dSpace Real Time Interface. Students also learn how to analyze the data by applying their knowledge in mathematics and engineering optimization until they achieve a satisfactory level of the optimization results compared to the acquired laboratory data.

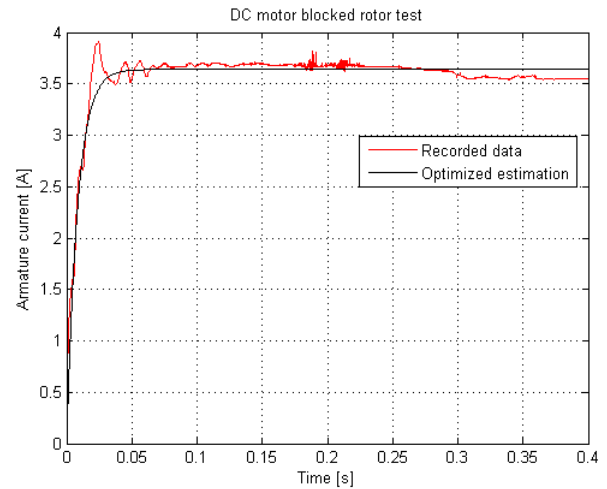

Fig. 7. DC motor blocked rotor recorded step response with LSE optimally estimated step response

III. INDUCTION MACHINE SPEED CONTROL ANALYSIS

In this experiment students get hands-on experience on to the study of Torque-speed characteristics and speed-control of a 3-phase induction machine. The objectives of this experiment are to study the torque speed characteristics of a three phase induction motor as well as to study the characteristics of the induction motor in both generation mode (super-synchronous speed) and motoring mode (sub-synchronous speed). Speed control of the three phase induction motor is performed by slip compensation without speed feedback and slip compensation with speed feedback.

A. Induction Machine Speed Control Experiment

The preparation for the lab needs development of the AC 3-phase induction motor per phase equivalent circuit as presented in Fig. 8. In a previous experiment students determined the per-phase equivalent circuit parameters of the induction motor under the test.

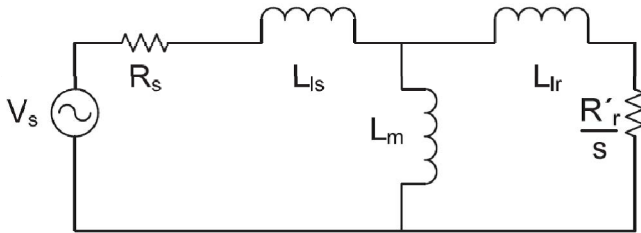

Fig. 8. Per-phase equivalent circuit of a 3-phase induction motor

The laboratory equipment used in the experiment are DC regulated power supply, power electronics drive board, 4-channel digital oscilloscope 100 MHz, 4-pole induction motor (200 W, 30 V_{AC}, 3621 rpm @ 128 Hz, 5.7 % rated slip), DC motor 200 W, 42 V_{DC}, and dSpace CP 1104 I/O board supported by Matlab Simulink [7] and dSpace [8] programs.

The block diagram for the lab bench set up to conduct the induction motor speed control experiment is shown in Fig. 9.

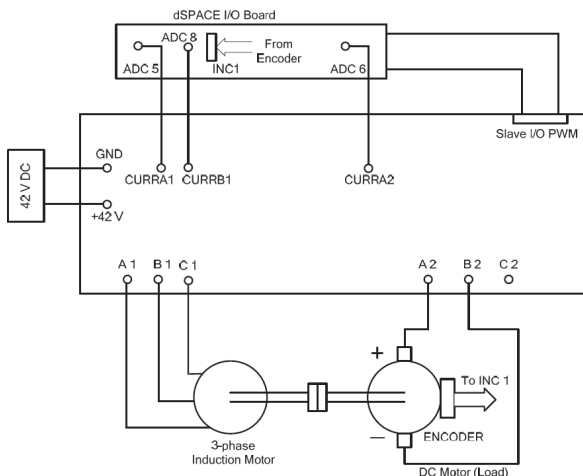

Fig. 9. Experiment setup for speed control of the 3-phase induction machine

In this part of the experiment the speed of the induction motor is maintained at 725 rpm, while the input frequency is

maintained at the values corresponding to synchronous speed of 810, 900, and 990 rpm for the 4-pole machine. The torque vs. frequency characteristics are expected to be linear in a narrow range around the synchronous frequency, i.e. $T_{em} = K_{T_o} \cdot \omega_{slip}$. In the linear region the torque is proportional to the slip frequency in the rotor, as depicted by the linear parts of the characteristics for various input frequencies in Fig. 10.

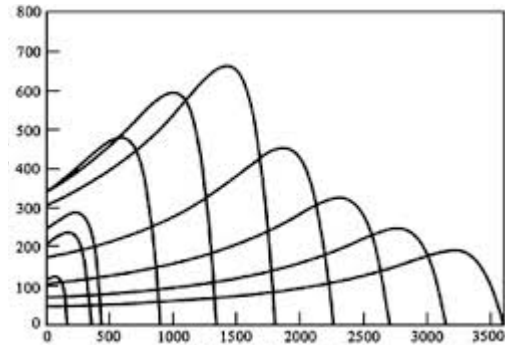

Fig. 10. Induction machine torque vs. frequency characteristics

B. Induction Machine Speed Control Analysis

Measured and calculated values of output active and input apparent electrical powers keeping the induction machine mechanical speed at 725 rpm are shown in Table 1 below.

TABLE I. POWERS VS. FREQUENCY AT 725 RPM

ω_{in} (rpm/Hz)	ω_{out} (rpm)	ω_{slip} (rpm)	P_{out} (W)	S_{in} (VA)
810/27	725	85	3.0	3.6
900/30	725	175	6.2	15.2
990/33	725	265	9.4	23.5

The input voltage and current snapshot at $f = 30$ Hz is shown in Fig. 11 [8]. Calculations show that the phase difference between the input voltage and current is $\phi = 48.6^\circ$, which corresponds to power factor $PF = 0.66$. Students observe that linear torque vs. frequency characteristic doesn't necessarily match with the desired power factor and efficiency and it should be carefully considered in the induction motor design to meet the application specification.

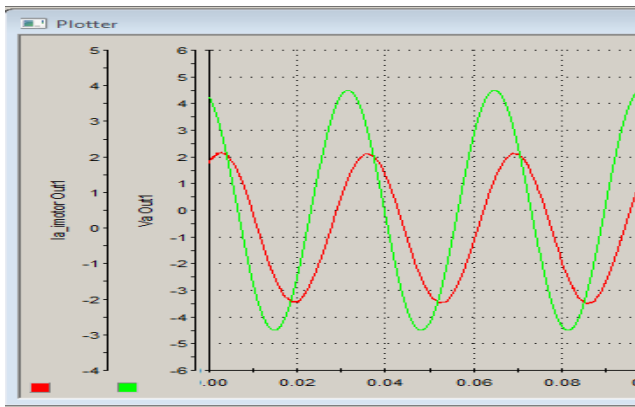

Fig. 11. Induction machine voltage and current snapshot at $f = 30$ Hz

Additional observation and Fourier transform analysis show that there exists 19th current harmonic in the amount of 0.5 %, due to power electronics frequency modulation, as can be seen in Fig. 12 [7].

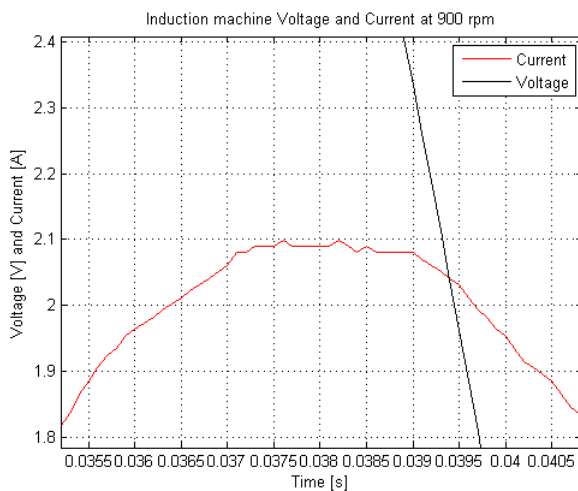

Fig. 12. Presence of 19th current harmonic in the Induction machine current vs. time snapshot at $f = 30$ Hz

C. Educational Outcome

In the 3-phase induction machine speed control experiment, students develop a testing algorithm using advanced technology hardware environment and software environment of Matlab Simulink [7] and dSpace Real Time Interface [8]. They analyze the acquired data and observe that specific application based design consideration is necessary to achieve optimal working conditions for the machine. Students also demonstrate their ability to analyze and interpret the data by applying their knowledge in discrete Fourier transform, detecting the current harmonic components, and developing the requirements for specific current harmonic suppression.

IV. CONCLUSIONS AND FURTHER IMPROVEMENTS

By completing several hands-on experiments students demonstrate their in-depth understanding of the subject matter and capabilities to conduct complex laboratory experiments, acquire, analyze, and interpret the data, and develop the

criteria for further optimization as well as application based design requirements.

As a part of further curriculum development effort we in the Syracuse University College of Engineering and Computer Science have implemented the newest communication technology to achieve distant learning capabilities. The distant learning technology generally cannot replace regular laboratory work, but it can improve students' familiarization with the modern laboratory equipment, before they enter into the advanced laboratory environment. This is particularly important since the newer technology implementation requires additional preparation time for the next level of laboratory work.

REFERENCES

- [1] N. Mohan, "Electric Machines and Drives, A First Course", John Wiley & Sons, Inc., 2012
- [2] G. R. Slemon, "Electric Machines and Drives", Addison-Wesley Inc., 1992
- [3] A. E. Fitzgerald, C. Kingsley Jr., S. Umans, "Electric Machinery", McGraw Hill, 2003
- [4] N. Mohan, T. M. Undeland, W. P. Robbins, "Power Electronics: Converters, Applications, and Design", 3rd edition, John Wiley & Sons, Inc., 2003
- [5] B. K. Bose, "Modern Power Electronics and AC Drives", Prentice-Hall, 2001
- [6] M. P. Kazmierkowski, R. Krishnan, F. Blaabjerg, J. D. Irwin (editors), Control in Power Electronics, Academic Press, 2002
- [7] Mathworks: Matlab 2013b
- [8] dSpace: Real Time Interface 2013b

Dr. Tomislav Bujanovic is a research associate professor at Syracuse University. He has done work in the area of power capacitors and their application in industrial and utility distributive systems and smart grid in power engineering, as well as medical signal analysis and motion estimation in time-varying images in signal processing.

Dr. Prasanta Ghosh is a professor in the department of Electrical Engineering and Computer Science at Syracuse University. He has been conducting research in the area of microelectronics and power engineering. He has authored or co-authored many journal articles and conference papers in the area of thin films, solid state devices, and power engineering. His current research focus includes smart grid, sensors, and optimization of distribution system with distributed source. He is a senior member of IEEE.