

An Apparatus for Monitoring the Health of Electrical Cables

D. M. Pai¹, Paul F. Tatum² and M. J. Sundaresan¹

¹Center for Advanced Materials and Smart Structures

²Undergraduate Research Assistant, Intelligent Structures and Mechanisms Lab

Dept of Mechanical Engineering
North Carolina A&T State University
Greensboro, NC 27411

Introduction

As with most elements of infrastructure, electrical wiring is innocuous; usually hidden away and unnoticed until it fails. Failure of infrastructure, however, sometimes leads to serious health and safety hazards. Electrical wiring fails when the polymeric (usually rubber) insulation material that sheathes the conductor gets embrittled with age from exposure to pressure, temperature or radiation cycling or when the insulation gets removed by the chafing of wires against each other. Miles of such wiring can be found in typical aircraft, with significant lengths of the wiring immersed in aviation fuel – a recipe for an explosion if a spark were to occur. Diagnosing the health of wiring is thus an important aspect of monitoring the health of aging aircraft. Stress wave propagation through wiring affords a quick and non-invasive method for health monitoring. The extent to which a stress wave propagating through the cable core gets attenuated depends on the condition of the surrounding insulation. When the insulation is in good condition – supple and pliable, there is more damping or attenuation of the waveform. As the insulation gets embrittled and cracked, the attenuation is likely to reduce and the waveform of the propagating stress wave is likely to change. The monitoring of these changes provides a potential tool to evaluate wiring or cabling in service that is not accessible for visual inspection. This experiment has been designed for use in an introductory mechanical or materials engineering instrumentation lab. Initial setup (after procuring all the materials) should take the lab instructor about 4 hours. A single measurement can be initiated and saved to disk in less than 3 minutes, allowing for all the students in a typical lab section to take their own data rather than share a single set of data for the entire class.

Procedure

Mounting board

Materials

- Board, pine – 1 pc. 12 in. x 12 in. x 0.75 in.
- Wire, copper 10 gauge 15 ft.
- Wood tiles (4) 2 in. x 2 in. x 0.25 in. (cut from the 2 in. x 4 in. board) (four one inch flat brackets may be substituted for the wood tiles)
- Wood screws (8) 1 in.

Manufacturing procedure

1. Set the height of the blade on the table saw to $\frac{1}{4}$ in. above the table deck. Use the pencil to draw two equally spaced lines along the grain of the wood.
2. Cut a $\frac{1}{4}$ in. deep groove along each line with the table saw.
3. Measure the insulated wire and use a magic marker to mark it at 10 ft. from one end.

4. Press the 0 ft. end of the wire into one of the grooves leaving 12 in. of wire extended away from the wood.
5. Place a 2 in. x 2 in. wood tile over the wire and groove at each end and screw into place with two wood screws, securing the wire in the groove at both ends of the groove.
6. Bend the wire back over the wood so that the end is suspended above the groove.
7. Place the wire into the second groove so that the ten foot mark is suspended over the second groove by bending the wire appropriately.
8. Neatly coil the wire between the end and the 10 ft. mark, There should be 5 ft. of excess wire extending beyond the 10 ft. mark.

Creating the sensors

Materials

- Brass rod, hexagonal
- Conductive epoxy
- Copper wire 22 gage red
- Copper wire 22 gage black
- Piezoelectric material, six pieces cut to 0.75 in. x 0.25 in.
- Soldering iron and solder

Manufacturing procedure

1. Cut off a 1.5 in. piece of brass (sensor body).
2. Cut off a 0.5 in. piece of brass (end cap).
3. Drill a 0.25 in. through hole in each piece.
4. Drill a 0.5 in. hole through the 1.5 in. piece of brass until the tip of the drill bit reaches the end of the brass. Do not drill all the way through.
5. Machine the end cap 0.5 in. diameter by 1/8 in. down the length so that it fits into the sensor body.
6. Cut 6 pieces of PZT to 0.75 in. by 0.25 in.
7. Lightly sand each face of the brass sensor body with sand paper.
8. Spread a thin coat of epoxy on each piece of PZT and affix them to each face of the sensor body making sure not to allow any epoxy to squeeze up the side of the PZT.
9. Place sensor under a 60 watt light bulb and allow to cure for 24 to 48 hours.
10. Place a bead of solder on one end of each piece of PZT.
11. Strip the insulation off of a 3 in. piece of 22 gage copper wire and unravel one strand of copper wire.
12. Use the soldering iron to attach the strand of wire to each solder bead to connect all six of the pieces of PZT together.

Attaching the BNC jacks

Materials

- BNC jacks (3)
- Solder
- Wire, copper 22 gauge black and red
- Aluminum foil

Manufacturing procedure

1. Cut 5 in. of black and red 22 gauge wire.
2. Strip the insulation from both ends of each wire to 0.125 in. from each end.
3. Solder the red wire into the center post of the BNC jack and the black wire to the ground connection.

4. Cover both connections with electrical tape.
5. Use the soldering iron to connect the red wire to one of the beads of solder on one tile of PZT.
6. Solder the black wire to the side of the main body of the brass sensor making sure to avoid any connection with the PZT pieces directly.



Figure 1. *An assembled BNC jack with leads*

Placing the sensors on the wire

1. Thread the sensor and end cap along the 10 gage wire until it is at the 10 ft. mark by removing and replacing the wood tiles as needed.
2. Glue the end of the sensor to the wire by sealing the 0.25 in. hole with hot glue and let set.
3. Fill the sensor with hand lotion using the syringe making sure to stir out any bubbles with a tooth pick.
4. Place the brass end cap on the sensor and secure it to the wire by sealing the end hole with hot glue.
5. Place a few drops of glue on the joint of the end cap and sensor body to keep the cap in place.
6. Attach a coaxial cable to the BNC jack.
7. Tape the coaxial cable to the 10 gage wire.
8. Cover the sensor carefully with rubber from the rubber glove and secure with tape, making sure to leave the BNC jack exposed.
9. Cover the sensor and BNC jack with aluminum foil and ground the foil to the BNC jack with a clip.
10. Repeat steps 1-9 with the second sensor, placing it at the 0 ft. end of the wire.

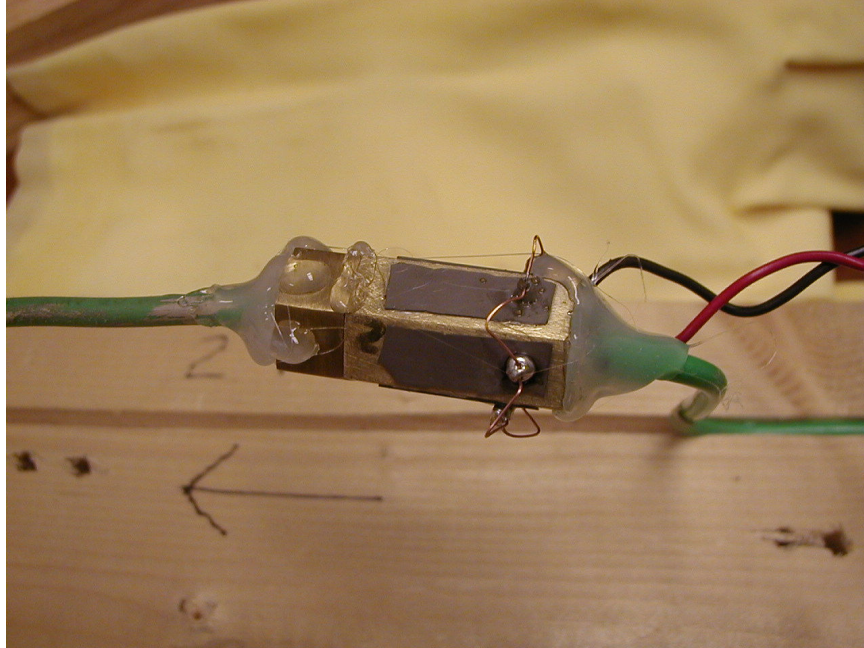

Figure 2. Complete sensor mounted on the wire.

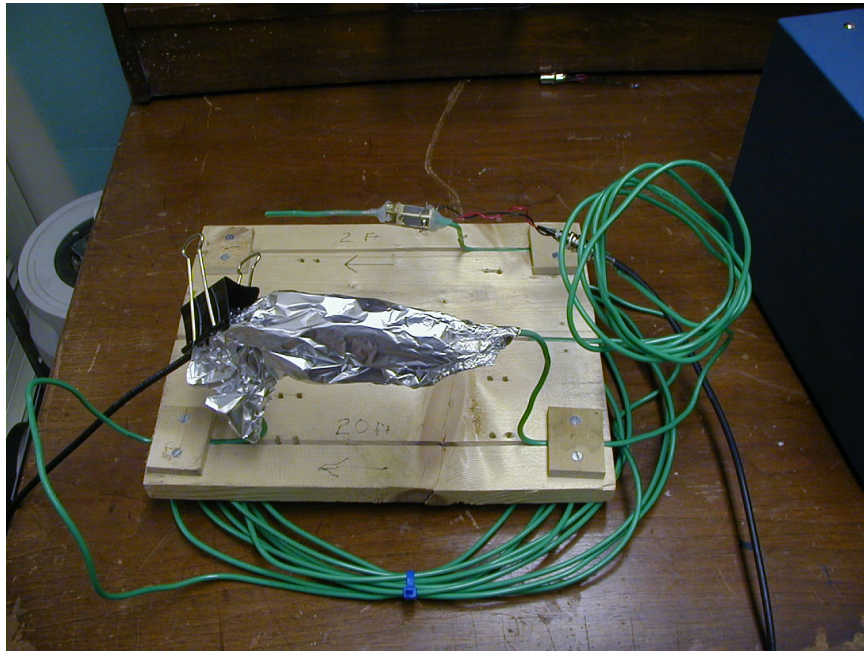

Figure 3. Completed setup with mounting board



Figure 4. Diagram of the completed apparatus with the actuator at the origin and the sensor at 10 ft, with damaged insulation in-between the two.

Connecting the function generator, amplifier and oscilloscope

Warning: Care should be taken when using the voltage amplifier. A direct connection between the output of the voltage amplifier and one of the sensors can cause serious damage to the oscilloscope.

1. Using coaxial cables (or appropriate connectors for your oscilloscope) connect the sensor to channel 1.
2. Connect a coaxial cable from the OUTPUT jack on the function generator, using a Y jack, to channel 2 of the oscilloscope.
3. Connect the function generator OUTPUT to the voltage amplifier INPUT.
4. Connect the voltage amplifier OUTPUT to the sensor located at the end of the wire. This sensor will now be referred to as the actuator as it will be generating the wave from the inputted voltage. *IMPORTANT! Once the cable is connected to the actuator cover all metal on the actuator with rubber cut from the rubber cleaning glove (or other insulating material) and tape securely into place.* Should the metal of the actuator touch the aluminum foil of the sensor at the 10 ft. mark it could cause serious damage to the oscilloscope.
5. Set the oscilloscope to trace channel 1 to A.

The apparatus is now ready to begin testing.

NOTE: To test that the sensors are functioning properly you can connect each sensors cable directly to the function generators OUTPUT, then using a constant sine wave set between 4 kHz and 15 kHz at 9 V_{p-p} listen for a tone. The sensors will create an audible tone when working properly.

Collecting Data

1. Set the function generator to burst mode to generate 5 pulses of 10.4 kHz frequency with amplitude of 1 V_{p-p}.
2. Attach a coaxial cable connecting the trigger jack on the function generator and channel 2 on the oscilloscope. Making sure the oscilloscope trigger is set to channel 2 and that channel 1 is set at 2 ms and 6 V.
3. Use the trigger on the function generator to send a five wave burst to the actuator.
4. Confirm that a signal is registering.
5. Adjust the voltage on the oscilloscope as needed and increase the voltage of the function generator as needed using increments of 1 kHz.
6. Fine tuning of the signal can be done by adjusting the frequency in small increments until the best signal is received at the sensor. Once an adequate signal is registered set the trace channel A to collect 20 sweeps averaged to eliminate noise.

Data

Figure 6 shows a 10.4 kHz pulse passing through the wire with undamaged insulation. Two peaks are shown. At approximately 1.75 milliseconds the voltage peaks at approximately 0.013 volts, then at approximately 3 milliseconds the voltage peaks again at approximately 0.007 volts.

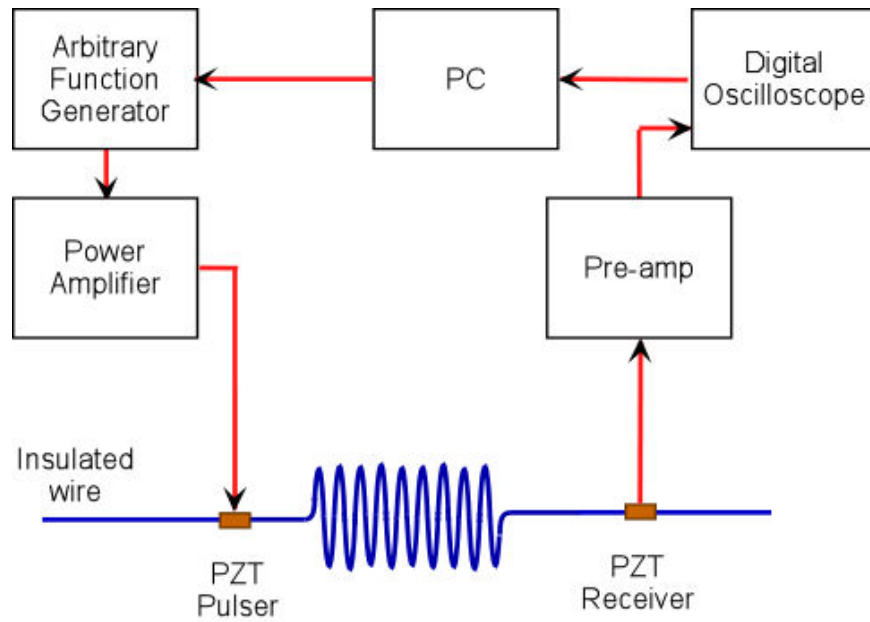

Figure 5. *Experimental setup diagram*

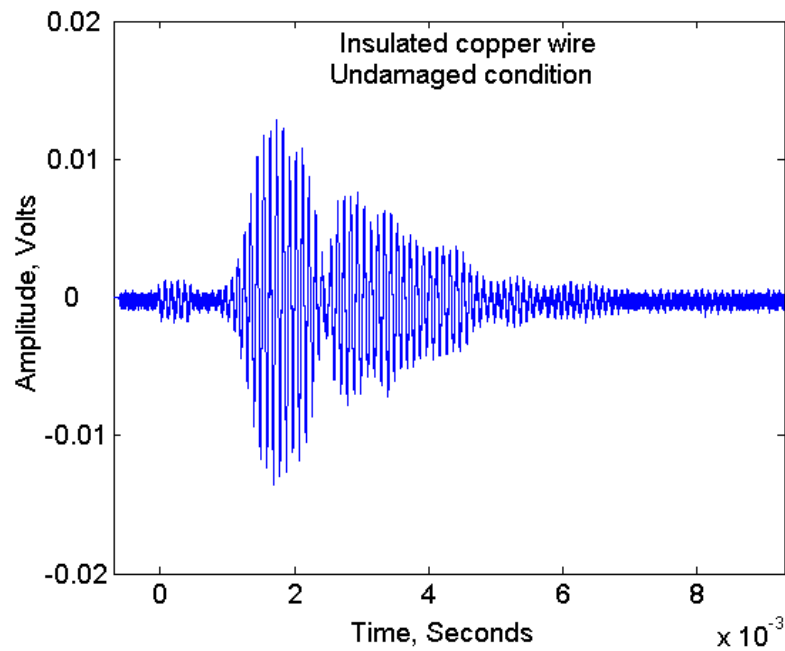

Figure 6. *The initial wave form as it passes through the wire with undamaged insulation.*

The insulation on the wire was burnt using a propane torch. The burnt insulation became brittle and cracked. Figure 8 shows the wave passing through the wire with the insulation burnt. As the wave passed through the wire the dampening effect of the insulation was not as evident and the voltage of the wave appears to have increased at the sensor. Again two peaks are visible at approximately 1.8 and 2.75 milliseconds with a peak voltage of .018 volts for each peak

The burnt insulation was removed to expose the copper wire. When the wave passed through this section it reverted to its original form of two peaks, with the second being smaller than the first. The voltage in the third pass was uniformly higher than that of the first pass. The embrittled insulation appears to have had a noticeable effect on the wave.



Figure 7. *Insulation charred with a propane torch.*

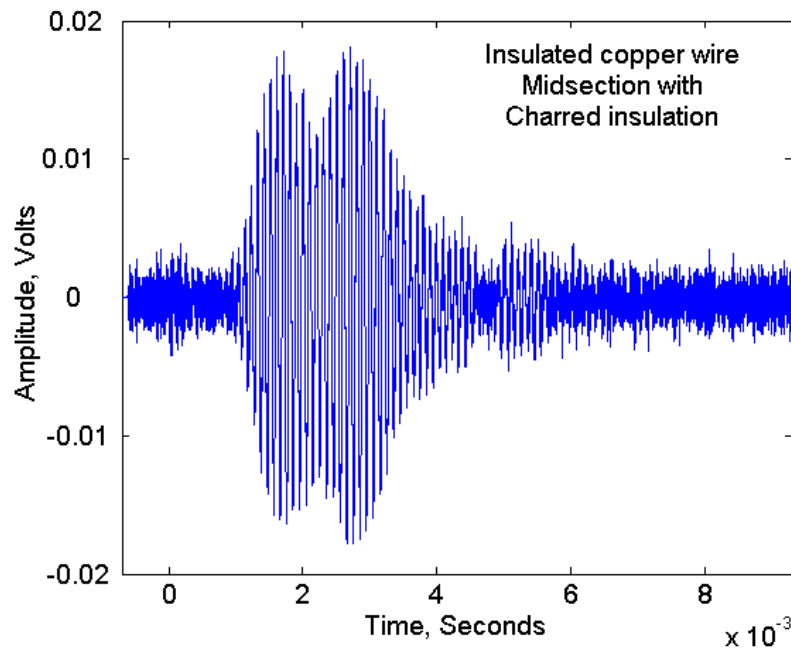

Figure 8. *The wave form as it passes through the wire with burnt insulation.*

Figure 9 shows the wave form passing through the wire with the damaged insulation removed. The wave form resembles the initial wave form but slightly amplified. Again the wave form was affected by the change in the condition of the insulation.

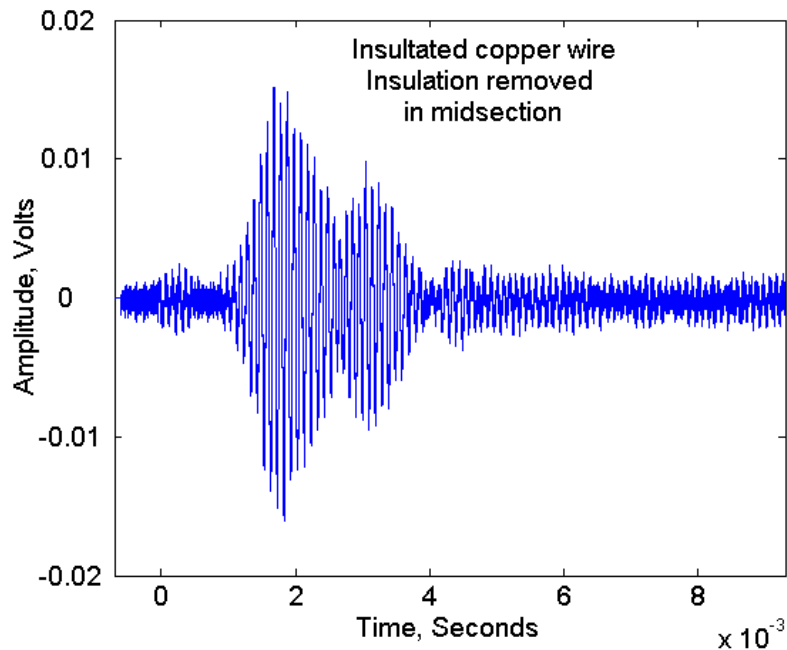

Figure 9. *The wave form as it passes through the wire with the damaged insulation removed.*

Comments

Wave propagation through materials is complex and interpreting the results can take time. The initial objectives of this project were to make sensors that can produce measurable data related to the condition of the insulation of the wire. By manufacturing piezoelectric sensors that can measure the amplitude of a wave passing through a wire and changing the condition of the wires insulation, information can be collected and analyzed to determine the condition of the wires insulation.

This project was successfully able to manufacture these sensors and demonstrate that they can measure the amplitude of the wave and detect the differences in the wave form as it is affected by the change in the condition of the wires insulation. The sensors used are moderately inexpensive and easy to make, and are robust enough to be reused and moved along the wire.

This paper demonstrates the manufacture and use of piezoelectric sensors attached to a common insulated electrical wire to monitor sound waves passing through the wire. It is a moderately inexpensive and compact apparatus that can be used to demonstrate how sound waves behave in an insulated wire.

Acknowledgement

The authors wish to gratefully acknowledge financial, equipment and computing support for this project from the NSF Center for Advanced Materials and Smart Structures, the NASA Center for Aerospace Research and the NASA FAR grant NAG8-1897 at NC A&T State University.

Biographies

Devdas M. Pai is a Professor of Mechanical Engineering at NC A&T State University and Associate Director (Operations) of the Center for Advanced Materials and Smart Structures. He received his M.S. and Ph.D. from Arizona State University. He teaches manufacturing processes and tribology related courses. A registered Professional Engineer in North Carolina, he serves on the Mechanical PE Exam Committee of the National Council of Examiners for Engineers and Surveyors and is active in several divisions of ASEE.

Paul F. Tatum has participated in the NASA-FAR program and has worked in the Intelligent Structures and Mechanisms Lab at NC A&T State University in the field of structural health monitoring. Paul is currently in his junior year in the Department of Mechanical Engineering and is participating in the NASA Co-operative Education program at the Marshall Space Flight Center in Huntsville, AL. He plans to pursue graduate school upon graduation in 2006. He is active in the student section of ASME, and is currently the Vice Chair of the Section.

Mannur J. Sundaresan is an Associate Professor of Mechanical Engineering at NC A&T State University and Director of the Intelligent Structures and Mechanisms Lab. He received his Ph.D. from Virginia Tech. He is active in the areas of structuring health monitoring and smart sensors research, with two patents and several technical publications. He teaches undergraduate and graduate courses on these topics as well as vibrations and instrumentation. He is active in several technical societies including SPIE, AIAA and ASME and serves on the editorial board of an international journal related to his research.

References

Anastasi, Robert F., and Madaras, Eric I., "Aging Wire Insulation Assessment by Phase Spectrum Examination of Ultrasonic Guided Waves," *SPIE's 8th Annual International Symposium on NDE for Health Monitoring and Diagnostics*, San Diego, California, March 2-6, 2003.

Pai, D. M., and Sundaresan, N. R., "The Use of Piezoelectric Materials in Smart Structures," Proceedings of the 2003 ASEE Annual Conference, (CD-ROM Paper #1740), Nashville, TN, June 2003.

Appendices

Equipment and Materials

The supplies listed below are separated into two categories; General Supplies that can be found in most physics and instrumentation labs and Special Supplies that will need to be purchased specially for this experiment.

General Supplies:

Acetone	Screws, wood
Aluminum foil	Solder, rosin core
Digital oscilloscope	Soldering iron/solder
Electrical tape	Syringe
Function generator	Toothpicks
Glue gun with glue sticks	Voltage amplifier
Hand lotion	Wire strippers
Machinist lathe	Wire, copper 10 gauge single strand
Metal ruler	Wire, copper black insulated 22 gauge
Multi-meter	Wire, copper red insulated 22 gauge
Rubber cleaning gloves	Wood board 2in.x 4in.x 12in
Sand paper 240 grit	X-Acto knife
Scissors	

Special Supplies

Material	Supplier	Part#	Qty.	Cost
PZT 5A (Lead Zirconate Titanate) 2 in. x 2 in.	Piezo Systems Inc. 186 Massachusetts Ave. Cambridge, MA 02139 (617) 547-1777 www.piezo.com	T110- A4E-602	1	\$100.00
BNC Jack	Radio Shack 300 W. 3 rd St. Suite 1400 Fort Worth, Texas 76102 (817) 415-3200 www.radioshack.com	Ug-1094	2	\$4.00
Conductive Epoxy	Epoxy Technology 14 Fortune Drive Billerica, MA 01821 Tel: 978.667.3805 Fax: 978.663.9782 http://www.epotek.com/contact-us.html	Epo-Tek H20-B	1	\$
Brass (360) hexagonal 9/16 in.	MSC Industrial Supply www.mscdirect.com 800-645-7270	32001497	1 rod	\$17.95

* Optional materials and tools for mounting board

Board, pine 12in. x 12in. x 0.75in.	Board, pine 2 in. x 4 in. x 12in	Wood screws-1&3/4 in (12)	12 in. table saw
--	-------------------------------------	------------------------------	---------------------