

MTSU's Experimental Vehicle Program's Outreach Events with an Emphasis on Recruitment

Dr. Saeed D. Foroudestan, Middle Tennessee State University

Dr. Saeed Foroudestan is the Associate Dean for the College of Basic and Applied Sciences (CBAS). The CBAS oversees 10 departments at Middle Tennessee State University. He is the professor of engineering. He is also the current Director for the Masters of Science in Professional Science. Foroudestan's academic experience includes teaching at Tennessee Technological University and Middle Tennessee State University in the areas of civil engineering, mechanical engineering, mechatronics engineering, and engineering technology. Foroudestan is the faculty advisor, coordinator, and primary fundraiser for EVP teams entering national research project competitions such as the Formula SAE Collegiate Competition, the Baja SAE Race, the NASA Lunar Rover, and the Solar Boat Collegiate Competition.

Lillian Marie Hardin

Middle Tennessee State University's Experimental Vehicle Program Outreach Events with an Emphasis on Recruitment

Abstract

The Experimental Vehicles Program (EVP) at MTSU originated in 2004 and competes in three vehicle intercollegiate design competitions annually including the NASA HERC Moon buggy, Society of Automotive Engineers (SAE) BAJA, and American Society of Mechanical Engineers (ASME) Solar Splash Speed Boat.

The EVP has sought to increase its membership by recruiting along Diversity Equity and Inclusion (DEI) guidelines. Specifically for the 2022-2023 school year the EVP recruited among diverse majors and actively courted sponsorship relationships to find internships and mentoring opportunities for our members.

The EVP annually hosts workshops for Civil Air Patrol high schoolers from across the nation, Boy Scouts of America Engineering merit badge university, as well as the Tennessee Girls in STEM biannually, while also taking requests from regional high school STEM programs for in school demonstrations and allowing seniors from those schools to tour the EVP facilities and ask questions about the process of creating the vehicles. Teaching material to others is a key component of learning. Outreach events allow EVP team members to teach fundamental principles of science and engineering through management of hands-on, experiential learning activities with visiting students of all ages. Engaging with local schools is beneficial for recruiting students planning to attend a university for engineering.

The EVP also attends several campus events to recruit new members, like MTSU's Scholars Week poster judging, Hack MT hackathon and the Homecoming parade. The current vehicle designs are presented to curious students, and the program has an opportunity to display their work. Any student can join EVP, as there are diverse majors throughout, and students learn through hands-on experience and guidance from current members.

Introduction

During the late 1990s to early 2000s institutions saw a significant decrease in the number of undergraduate students majoring in the STEM fields that focus on Science, Technology, Engineering, and Math. Among those who started pursuing a STEM degree, less than half received one [1]. Researchers have been looking at why this happens, focusing on both student traits and the college environment. Research suggests that to keep students interested in STEM, they need help in four areas: figuring out their career goals, setting realistic expectations, overcoming challenges, and building a support network [1]. The EVP is a program at MTSU that focuses on designing and fabricating innovative, exciting vehicle designs that compete in various competitions. The EVP speaks to interested students about engineering tasks and designs to increase their interest in STEM-related fields and recruit capable individuals to the program. Recruitment is critical for the success of new, innovative designs, and the program utilizes all major campus opportunities to display vehicle designs and upcoming projects. The program also utilizes the knowledge of senior members to create a mentorship between higher-level and

lower-level or new members. Lower-level members will learn various skills such as welding, operating machinery, and designing CAD assemblies. At any event the program is hosting, the goal is to provide a genuine insight into the engineering field and the skills required to be successful.

Owing to the trend to push for interdisciplinary objectives on the rubrics of all three vehicle competitions, the EVP has pivoted to recruiting students from disciplines outside of traditional Engineering. Recruits are found from MTSU's Aerospace and Construction Management and the Media and Art Departments. EVP's leadership looked for complementary clubs and found two exemplary recruits from the ranks of the golfcart mounted Cadets of the MTSU Police Blue Raider Patrol recruited Spring 2023. MTSU is well known for having the largest military veteran student population at a public university in Tennessee. The EVP actively seeks to capitalize on the skills they learned from military service, and their maturity helps temper some of our younger students. MTSU is also home to the largest foreign exchange population in the state, and we strive to recruit these students. Currently, the EVP has 20 active members on the NASA HERC project, 10 members contributing to the Solar boat, and 10 members contributing to the Baja project. In total, we have approximately 45-50 active members from diverse backgrounds dedicated to vehicle designs.

Previous designs, technical reports prepared for each vehicle, photos, test data, etc. regarding each vehicle are preserved in an online Knowledge Base allowing students the opportunity to quickly review what has worked in the past. They then can begin iterative design—standing on the shoulders of giants—and contribute a subsystem to a vehicle while still an undergraduate. We strive to introduce innovative, advanced vehicle designs to various groups of students to engage and motivate them to achieve their goals.

Documentation of Annual Competitions

The NASA HERC is a competition that challenges students to create their own rover design, which is a vehicle scientists take into space to collect samples and telemetry data. Figure one shows the EVP's rover design for the 2024 competition. During the competition students will need to complete various obstacles, like collecting samples while staying on their rover, while still completing the course in a timely manner. Students are also responsible for documenting a Proposal, Design Review, and Operational Readiness Review. The Proposal includes all safety guidelines the team will utilize, as well as all safety plans the safety officer must implement. Safety is the number one concern when dealing with heavy machinery and various hazardous materials, so implementing a detailed safety plan is crucial to the success of every team. Along with safety planning, each team must submit a budget for the entire rover assembly, and a detailed schedule for the project's completion. The Proposal teaches students that every project one pursues must be documented and planned before any design or build work can be started. The Design Review is a detailed documentation of the subassemblies and assembly of the rover and proves to NASA that the team can create a functional design that will successfully complete the course and obstacles. Finally, the Operational Readiness Review includes the prediction of

success for various obstacles and any major changes made to the design due to unforeseen issues.

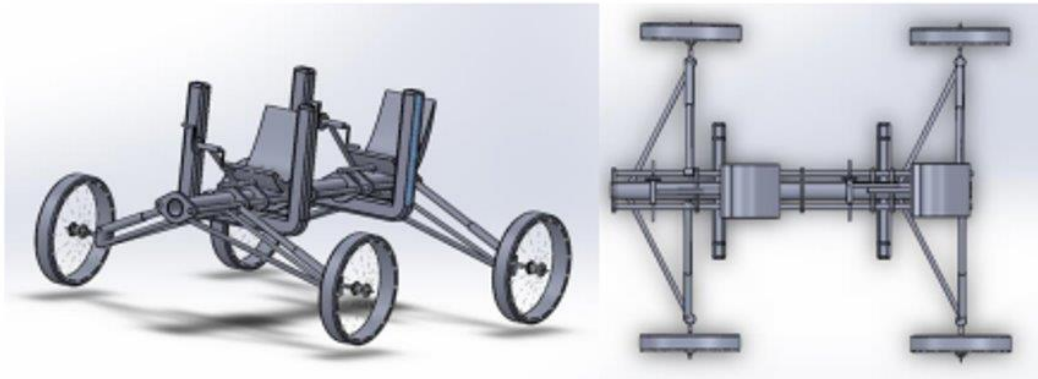

Figure 1: MTSU's 2024 Rover design.

Another competition students can participate in is the SAE Baja, which includes designing and fabricating a motorized buggy that can traverse through rough terrain without failing. Figure 2 shows the MTSU team in 2022 with their design. Students are also responsible for business and design documentation. The business plan is a required document for competing, and challenges students to create a fictional company with a market plan, business plan, revenue stream, and a cost analysis. Experience in creating an effective business plan will increase students' opportunities in the future and will form confidence in their skills to lead a project in their careers. The Design Review for the Baja competition is a detailed report of every subsystem on the vehicle and the overall assembly and analysis of assembly.



Figure 2: Baja vehicle produced by EVP members.

Lastly, the Solar Boat competition requires a technical report from all teams. The technical report includes all the major design components, simulations, and the reasoning behind each component. This allows students to gain skills in CAD, technical writing, and increases the design-thinking process. Students who participate in the vehicle competitions have seen the design thinking process multiple times and can utilize the skills learned from documentation in their future careers. Figure 3 shows the current boat design the EVP is using in the 2024 competition.



Figure 3: Current boat hull for MTSU's EVP.

When hosting STEM engagement events, the documentation portion of the vehicle competitions are discussed in detail to show the amount of dedication and work it takes to start a successful assembly.

STEM Engagement Events

Studies show that America's global economic leadership highly depends on skilled STEM workers [3]. Different STEM programs help keep kids interested in science and technology careers. But one size doesn't fit all—what works for one age group might not work for another. Also, if a program is mandatory for all students in a school, it could have a different impact than a program that kids choose to join because they are interested in STEM. It is unlikely that a short-term program will influence every middle-schooler's career choice [2].

There is also data pointing to a gender bias in STEM, which is widening the gender gap. Even when a department has had diversity training, women still feel less welcome and anticipate more discrimination than men [5]. This shows that just knowing about diversity issues isn't enough to fix the gender gap in STEM. The bias starts young. Teachers often unintentionally favor boys during STEM lessons, and this has not changed over the years [5]. Small but harmful interactions, like microaggressions, can make girls feel out of place in STEM from a young age. Bias leads to fewer women in STEM careers in the long run. To really close the gender gap, we must start early, focusing on the first steps of education in STEM [6].

Annually, more than 250 local students are invited to participate in several workshops and lectures regarding manufacturing, design, and vehicle completion. Throughout the lectures, students gain insight into the importance of hands-on learning in the engineering field and the dedication required to complete the three vehicle competitions. When hosting any STEM event, the program will first discuss the various requirements of the competitions and what the competition includes. EVP utilizes pictures from previous designs and knowledge of past team members to help students understand complex engineering ideas. After giving the lecture portion of the event, the program provides each participant the opportunity to operate the Rover and

Baja, as this creates excitement and motivation to pursue a design competition. Some of the highlighted events include Tennessee Girls in STEM (TGIS), Civil Air Patrol (CAP), and requests for local high school STEM events.

TGIS is a biannual event that is hosted by MTSU, and participants must register to attend. Registration ensures motivated students will be attending and students participating are excited to learn as it is not a requirement. TGIS is vital to EVP, as the program benefits greatly from diversity and individual ideas. Teaching the importance of STEM engagements while encouraging young women to pursue a degree or career in the STEM field is the highlight of these events. Speaking about the importance of hands-on learning and exposure to the engineering design process creates motivation for students to join a related program. Figure 4 shows excited TGIS students who are operating the 2022 rover design.



Figure 4: Students participated in the TGIS event and operated a NASA rover.

Recruitment via Events

A 2012 report from the President's Council of Advisors on Science and Technology said the U.S. needs a million more STEM graduates over the next ten years. To hit that target, we must get more students into STEM fields and keep them there. Surprisingly, many professors are not concerned or even aware of the need for more STEM graduates. They also do not know how they can help recruit and retain more students in STEM [4].

When it comes to helping students choose STEM, two things matter. First, they need practical advice on how to navigate college life, from where to live, to how to pay for it. Second, they need to understand the demands of a STEM curriculum, especially if they are coming from rural areas where STEM programs might not be as prevalent [3]. EVP is beneficial for the recruitment of STEM majors and retaining members via the engineering college's outreach program. The goal is to use proven theories and real-world research to create strong models for recruitment. Annually during the month of March, the organization attends MTSU's Scholars Week event. This event involves current students from all year levels. The three-vehicle designs are put on

display for students to admire, and this creates a space for interested students to join the program. EVP has had major success with recruitment and retainment from the Scholar's Week events, Hackathon and the Student Organization fair. To retain new members, the program strives to create a workplace where students are psychologically safe and feel comfortable discussing design options without damaging an individual's confidence in their engineering skills.

Diversity in STEM engagement and the Program

Today's STEM workforce is mainly comprised of male and either White or Asian, even though women and minority groups are expected to make up a larger portion of the U.S. population in the future [2]. To keep up with the growing worldwide need for STEM professionals, we must make STEM education accessible and successful for everyone in the U.S. school systems. Government bodies and other organizations must understand what obstacles students from diverse backgrounds face when trying to pursue STEM careers [3].

In EVP, we have several international students who have decided to participate in the program as well as two Graduate Assistants that are working towards Engineering Management degrees. Each diverse background ensures that students are exposed to differing opinions and methods for carrying out tasks. We also understand the hardships one may face while being an international student, and EVP can greatly increase one's ability to feel comfortable and open to expressing ideas while inside the facility. We also have many diverse majors and backgrounds included in the club, and this is beneficial as individuals have differing skillsets. Regarding the competitions, we strive to use all skillsets available to create the most innovative design possible.

Conclusion

EVP has much to gain from STEM engagement events, and keeping young students interested in engineering degrees is beneficial for STEM retention. Making future engineers intrigued by hosting events that display the work and dedication students put into each vehicle competition is our goal for participating in STEM outreach events. Another aspect of the STEM events is recruitment, as we host local high schools and strive to spark interest in the design process and EVP. Research shows an increasing need for diversity in the STEM workforces [5], and MTSU's TGIS event is a fantastic opportunity for young women who are interested in these fields to gain knowledge from hands-on tasks that would be done in their future careers. Another event that students can participate in is the Scholar's Week at MTSU, where individuals from diverse backgrounds can display a poster showing their projects/tasks. The EVP displays three vehicle designs, and recruit's students who are interested in the design process. Overall, recruitment and retention are critical to the success of the program, and STEM events are beneficial to both.

References

- [1] R. A. Kolvoord *et al.*, "Bridging the Valley: Recruiting and retaining STEM majors," *Journal of STEM Education: Innovations and Research*, vol. 17, no. 4, p. 8, Jan. 2017, [Online]. Available: <http://jstem.org/index.php?journal=JSTEM&page=article&op=view&path%5B%5D=2168>

- [2] R. Christensen, G. Knezek, and T. Tyler-Wood, "Alignment of Hands-on STEM Engagement Activities with Positive STEM Dispositions in Secondary School Students," *Journal of Science Education and Technology*, vol. 24, no. 6, pp. 898–909, Jun. 2015, doi: 10.1007/s10956-015-9572-6.
- [3] E. Gandhi-Lee, H. Skaza, E. J. Marti, P. G. Schrader, and M. Orgill, "Faculty perceptions of student recruitment and retention in STEM fields," *European Journal of STEM Education*, vol. 2, no. 1, pp. 1–11, Apr. 2017, doi: 10.20897/esteme.201702.
- [4] J. Jones, A. L. Williams, S. M. Whitaker, S. A. Yingling, K. K. Inkelas, and J. M. Gates, "Call to action: Data, Diversity, and STEM education," *Change: The Magazine of Higher Learning*, vol. 50, no. 2, pp. 40–47, Mar. 2018, doi: 10.1080/00091383.2018.1483176.
- [5] C. A. Moss-Racusin, C. M. Sanzari, N. Caluori, and H. Rabasco, "Gender bias produces gender gaps in STEM engagement," *Sex Roles*, vol. 79, no. 11–12, pp. 651–670, Feb. 2018, doi: 10.1007/s11199-018-0902-z. Shin, Jiyun Elizabeth L., Sheri R. Levy, and Bonita London. "Effects of role model exposure on STEM and non-STEM student engagement." *Journal of Applied Social Psychology* 46.7 (2016): 410-427.
- [6] T. Stephenson, M. Fleer, and G. Fragkiadaki, "Increasing girls' STEM engagement in early Childhood: conditions created by the conceptual PlayWorld model," *Research in Science Education*, vol. 52, no. 4, pp. 1243–1260, Apr. 2021, doi: 10.1007/s11165-021-10003-z.