

**AC 2007-1519: NSF GRANTEE PRESENTATION: RESULTS OF A
COLLABORATIVE REMOTE “OPTICAL CIRCUITS” LABORATORY
IMPLEMENTATION**

Deniz Gurkan, University of Houston

Alan Mickelson, University of Colorado at Boulder

Driss Benhaddou, University of Houston

NSF Grantee Presentation: Results of a Collaborative Remote “Optical Circuits” Laboratory Implementation

The ROCK (Remote Optical Circuits Knowledge) project is an NSF funded project that aims to create remotely-controlled optical circuits laboratory experiments. We expect this project to help introduce hands-on laboratory for distance education. While hands-on laboratory practices promise an engaging experience, effective teaching time can potentially be increased through the usage of remote-controlling capabilities of equipment and systems: since the setup will be always ready for demonstrations, the bulk of a laboratory session can be devoted to the more important fundamental concepts on the measurements, setups, system integrations, and component characteristics.

We propose to use remote control techniques to provide a complete set of laboratories covering optical circuits. We plan to implement laboratories of sufficient generality such that subsets of adaptations of this set of laboratories may be used for numerous lower, upper division undergraduate as well as for graduate courses and a wide variety of disciplines of technology and engineering. The key concept here is to introduce modularity so that resources can be used by different universities in different programs. Laboratory resources are being developed at both the University of Colorado and the University of Houston. Future implementations will be developed at the collaborating universities.

We are currently offering these courses at the engineering technology department at the UH and the electrical and computer engineering department at CU. A major component of our work will be outcome assessment and the continuous improvement model that will be used to adapt the laboratories to provide an effective hands-on experience to the students in different setting.

This paper will present set of laboratories that are already developed and pilot tested at the University of Houston and the University of Colorado. It will also present challenges and opportunities in developing remote laboratories for engineering distance education. Optical circuits is a field that we must study in some detail to determine its fundamentals and then find a set of experiments and exercises that will emphasize these basics. Although distance learning is an instructional method that is not usually associated with engineering laboratories, the need in our project is to come up with a good laboratory technique for students using only the distant environment. We also need to understand the separation between the reasons of deficiencies in student learning, whether they are due to inherent deficiencies in the distance learning technique or in implementation.

Our research will impact several aspects of our society affected by the educational system. The cost of education is now becoming a barrier to universal education. Distance learning can provide an economic alternative to in-class learning even when the student

population is primarily located on campus. In a commuter university setting, distance learning can have both an economic and environmental impact, reducing the time spent in needless transit which in turns conserves precious resources. Distance learning can provide the possibility for minority students to obtain their educational goals while working.

We will present our project results in the following sections: Course and lab integration, project objectives, course/lab web site, and student interaction in a pure virtual environment.

1. Course and Lab Integration

The course has been divided into a sequence of presentations: a theory lecture in the classroom would be followed with a simulation assignment on the concept. We have designed the simulations according to how the idealized systems would behave in an optical circuit. The simulation again would be followed with more theory and practices in the lecture. The last item in the sequence has been the lab practice.

For each laboratory the following material is developed:

Laboratory manual

Simulation software using VPIPlayer

Control software that enables remote control using Labview

Some video materials have been developed that would accompany instructions on how the equipment would be working behind the virtual instrumentation in addition to some explanations on the simulations. We have identified the need for video instructions through the experiences of our collaborators in University of Colorado. In the upcoming continuation of this project, we will develop accompanying video instructions to the experiments in order to give a better view of the systems.

2. Project Objectives

The phase 1 objectives are:

- to determine what set of fundamental concepts of optical circuits can be addressed in a laboratory environment,
- to parse each experiment undertaken into pieces that can be addressed by simulation, by visual exposition, by analytical exercise and by actual manipulation of equipment and
- to differentiate between the imperfection of our student' s learning and that of our teaching technique.

The laboratories are conducted in two steps. First, students are given a simulation to perform as a pre-lab. The simulation gets students to be prepared for the lab and study the concepts that will be dealt with. Then, students perform the lab using remotely-controlled equipment. Students write a report that is submitted through the rock website (<http://www.tech.uh.edu/rock/remotelabs.php>) (or any course management systems such as WebCT).

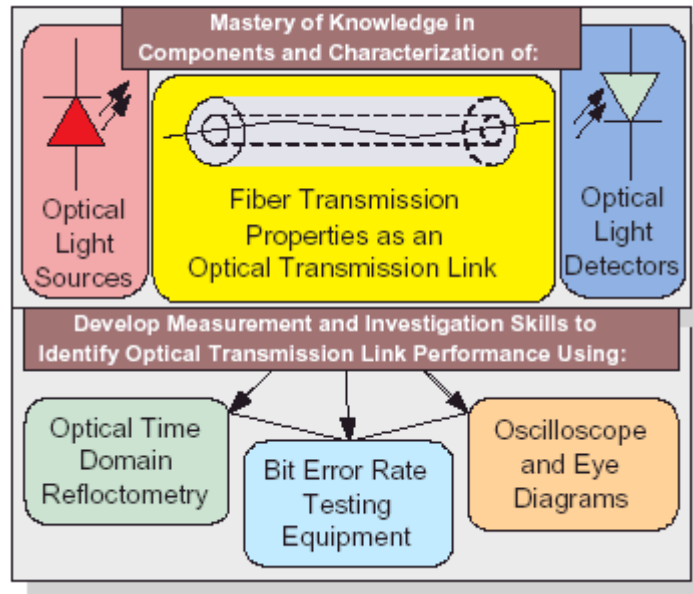

Figure 1. Laboratories and their corresponding concepts are depicted in this figure. The objectives have been linked to the laboratories as part of the learning plan.

Experiment 1 - Free Space Propagation Lab

This lab has been collaboratively used from the University of Colorado's course [1]. The experiment is based on modulation of a light beam using an audio signal and at the end, the retrieval of this information as audio.

Purpose: This experiment demonstrates the free space propagation and modulation/demodulation of light.

Experiment 2 – Dispersion

Purpose: The purpose of this experiment is to investigate material dispersion effects in optical fibers due to finite (non-zero) spectral width of optical sources propagating over a distance along the fiber.

Objective:

Characterize pulse distortion in graded-index multimode optical fiber due to material dispersion effects.

Compare pulsewidth distortion over two different fiber lengths using the laser source. You will be able to compare sources with different linewidths during the simulations.

Equipment, Components and Simulation Software

- VPIPlayer simulation software
- Pulse modulated optical source(s)
- Multimode optical fiber(s)
- Wideband photodiode receiver
- Oscilloscope

Experiment 3 - Fiber Loss Characterization

Purpose: The purpose of this experiment is the demonstration and understanding of fiber link characteristics such as link attenuation and connector loss.

Objective:

- Connector loss of a fiber link connection.
- Link attenuation per distance of various different fibers.
- Equipment, Components and Simulation Software
- The equipment used in this experiment includes:

Equipment, Components and Simulation Software

- VPIPlayer simulation software
- A multimode laser source
- Optical transmission fiber: multi-mode fiber (1 km and 2 km)
- Optical power measurement using OSA

This set of experiments examines a number of properties of the optical fiber link. There are 3 different cases to be explored:

1. Fiber connector loss: attenuation measurements before and after insertion of a connector to a link will provide the insertion loss. This loss will be measured using the multimode laser transmission.
2. Attenuation loss: the loss of power during transmission through a link.
3. Attenuation coefficient: Per km loss induced by the link.

Optical Fiber Connector Loss Examination: In this experiment the optical loss at a spool of fiber is being determined. One connection is through a patchcord which is about 1 m long. The same optical signal is sent also through a spool of fiber of unknown length. The fiber attenuation has been examined.

Experiment 4 - Optical Light Source Characterization

Purpose: The purpose of this experiment is to investigate spectral characteristics of two standard transmitter sources employed in optical circuits; the laser diode and the light emitting diode (LED).

Objective: At the end of this experiment you will characterize the bandwidth of a light emitting diode (LED) and a laser diode that are used as optical sources.

Equipment, Components and Simulation Software

- VPIPlayer simulation software
- The equipment used in this experiment includes:
- A laser source
- An LED Source
- Optical Spectrum Analyzer (OSA)

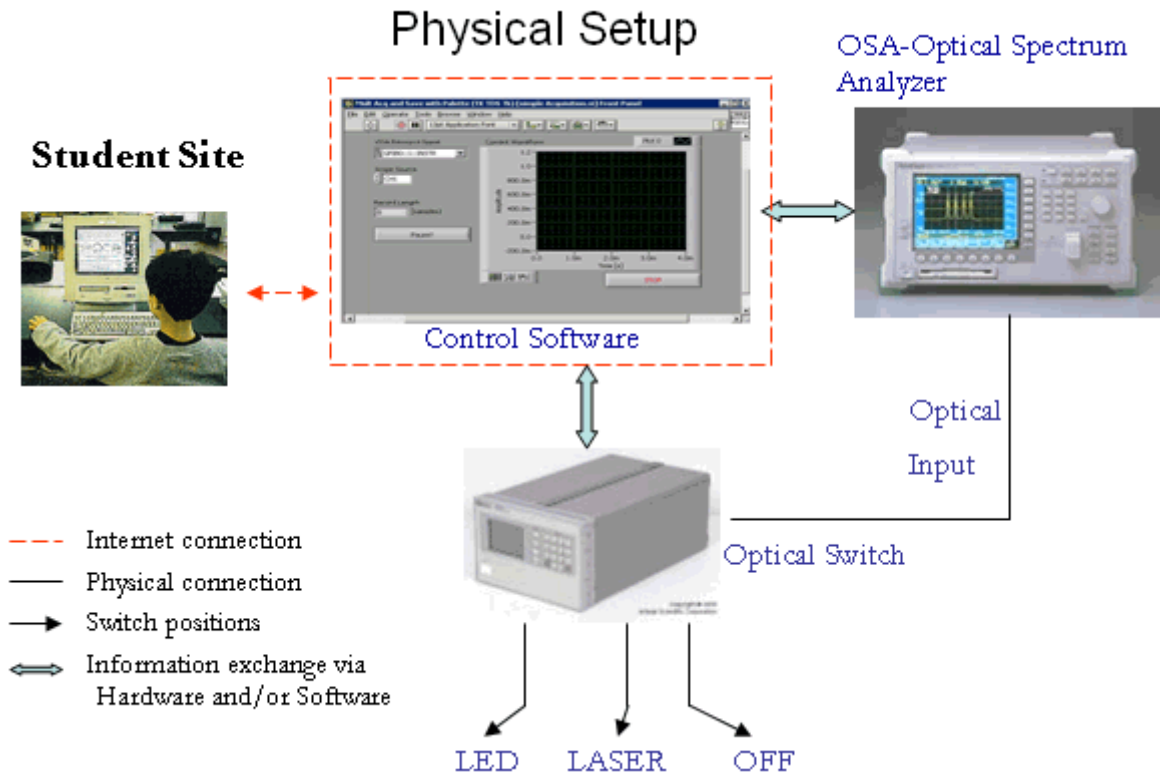

Figure 2. The figure represents the components of the virtual laboratory with a connection to different light sources through an optical switch.

Experiment 5 - Optical Detector Characterization

Purpose: The purpose of this experiment is to investigate the optical detectors and their operation of converting an optical signal into an electrical one.

Objective: At the end of this experiment you will be able to characterize a couple of the characteristics of optical detectors. One of them is their sensitivity on the wavelength and the other is on their responsivity

Equipment, Components and Simulation Software

- VPIPlayer simulation software
- Pulse modulated optical source(s)
- Wideband photodiode receiver
- Oscilloscope photodetector

Experiment 6 - Bit Error Rate

Purpose: The purpose of this experiment is to investigate transmission of information over an optical link and measurement of bit error rate.

Objective: At the end of this experiment you will be able to understand what BER measures and the power penalty of a system on the transmission path of the optical signals.

Equipment, Components and Simulation Software
Pulse modulated optical source(s)

Bit Error Rate: This lab will demonstrate how signal to noise ratio, photodetector responsivity, and fiber transmission impairments can be brought together for a general understanding of optical transmission.

Bit Error Rate Measurement: Bit error rate (BER) is the ratio of the number of erroneous bits received to the total number of transmitted bits. This is an estimate average rate of errors in the transmission. The error may result from transmission impairments on the fiber optic link as well as power loss through propagation. Naturally, the BER will be related to the signal-to-noise ratio (SNR) of the optical signal. In addition, the photodetector responsivity relates to the electrical conversion of the optical signal. The more photons are received per bit, the better the extinction ratio of the bit stream will be at the electrical end.

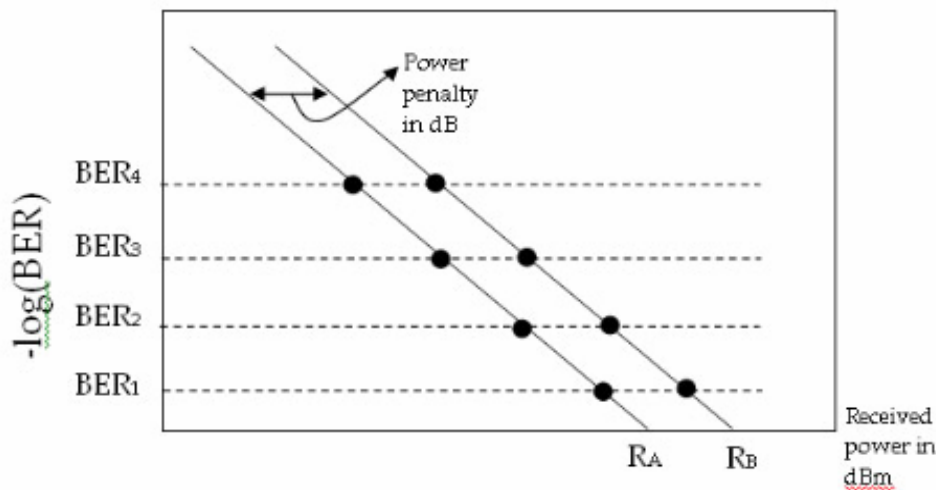

Figure 3. Power penalty and BER relationship.

A BER measurement can be taken for different received power levels to have an idea on the performance of the transmission line. In this case, the transmission line is the system that resides between the transmitter and the receiver. If, everything kept equal, we insert more fiber in the transmission line, the power required to achieve the same bit error rate will be higher. The required amount of the increase in power to achieve the same BER level is the power penalty introduced by the extra fiber.

The BER can be measured for one system for individual received power levels as depicted in Figure 3 for a system A and then for a system B. The difference in received powers to obtain the same level of BER is the power penalty of system B with respect to the system A.

3. Project Web Site at University of Houston

The project has been hosted on a web site as a repository of all components of the labs.

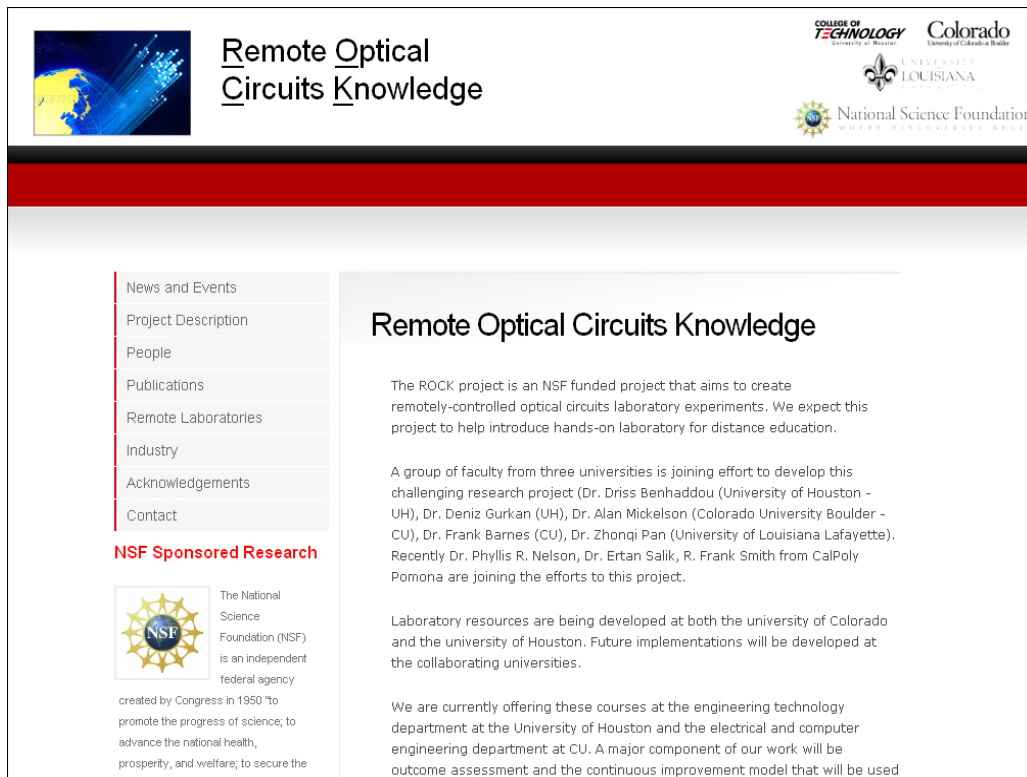

Figure 4. Remote labs have been posted on the project web site for collaboration and student access.

The web site has been a useful tool to post the virtual experiments and automate access of virtual labs. The lab manuals have been stored into a database similar to online educational tools in order to automatically retrieve all information about the student practices on the experiments.

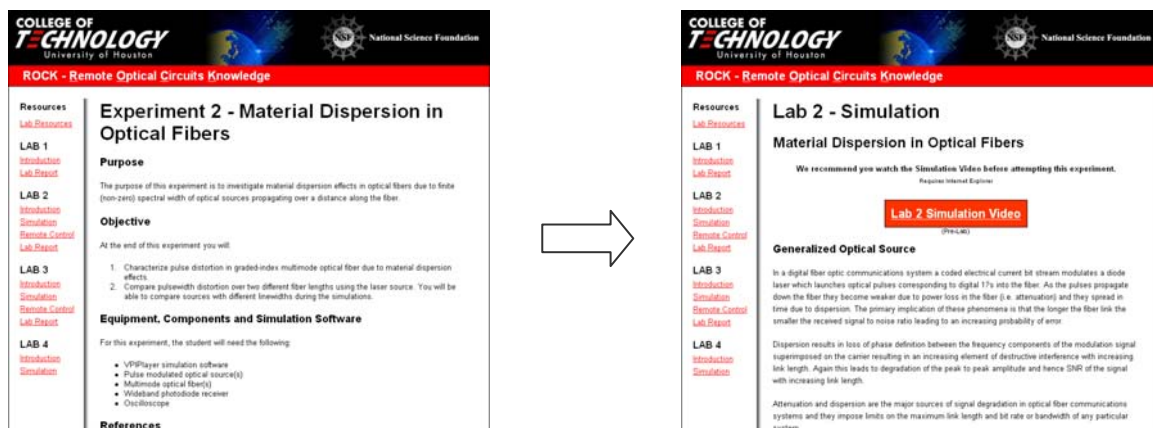

Figure 5. The experiment objectives and lab information with procedures are linked to the experiments in a logical way to help students navigate through the web sites towards the report of the lab.

Lab simulation is also posted on this web site for easy access by the students. We believe the web-based access mechanism helped to clear the process and also completed the main idea of having a virtual laboratory.

**Lab Remote Control allows students to:
View Lab Videos
Connect to experiment using LabView VI
Control LabView Remotely**



Figure 6. Many aspects of the experiment have been put together in this figure to demonstrate the access mechanism as well as emphasize the complicated media requirements in a virtual experiment. The orientation video screen, optical spectrum analyzer picture and spectrum screen and the web site links have been displayed.

The web site has all support mechanisms to store and display lab components in the electronic format. Students are independent of space and time requirements in the educational practice.

Remote Lab Reports

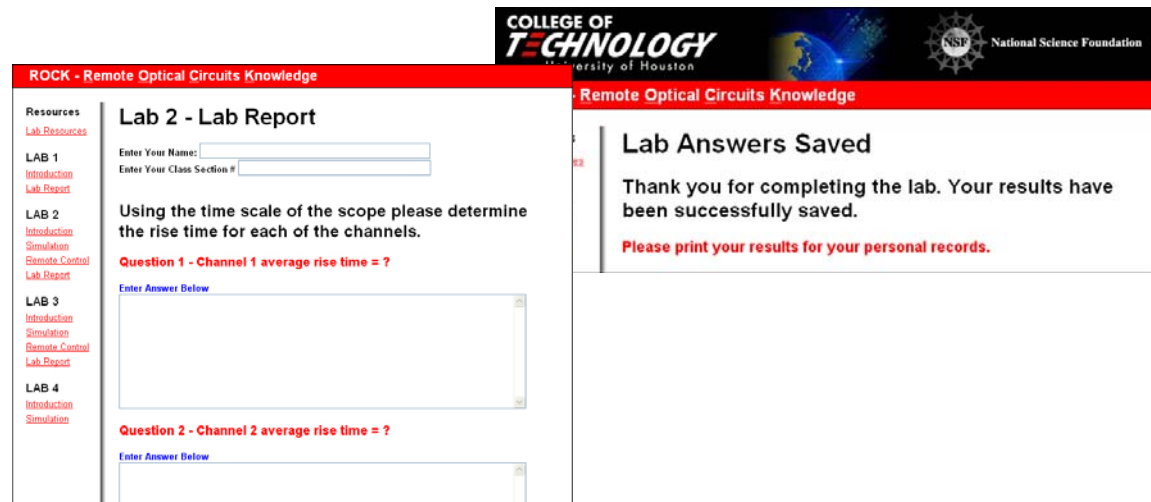

Figure 7. Lab manual questions and measurements are stored into a database and then e-mailed to the instructor at the end of each experiment.

4. Assessment

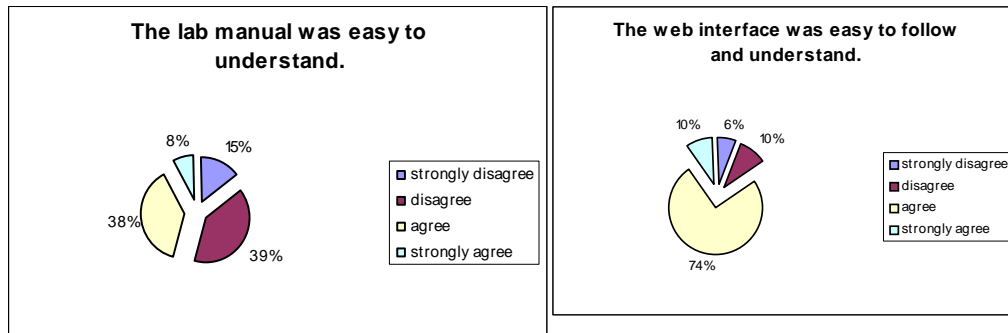

Figure 8. Student opinions on their experience have been collected.

Students have agreed on the ease of use of the web interface as well as the laboratory experiments. A sample lab manual has been attached to this paper as an appendix.

Students have been assessed on a hands-on experiment where they were tasked to measure the spectrum of two not identified sources and then asked to identify the LED vs. LD after completing the measurements. This experiment also assesses student ability to work with the OSA instrument. Then students were tasked to measure the temporal characteristic of a modulated LD using a high bandwidth oscilloscope. The results showed that only 25% of students were able to adjust the OSA while 54.5% of students were able to adjust the oscilloscope. This can be explained by the fact that OSA related remote laboratories did not mimic the view of the real OSA but rather only some useful buttons. While the experiments that involves the oscilloscope showed almost the real view of the oscilloscope with some limitations. We believe that we should update the virtual instrument view to include all the buttons on the real experiments and make the set up more challenging by making students to adjust the remote experiment to be able to measure the signal. In the present implementation, the instrument is automatically set up to view the signals and it is easy for student to collect the results.

Hands-on Laboratory: A hands-on version of the overall virtual experiment has been conducted by the students to observe the amount of transferred skills from the e-labs to the actual setup.

Table 1. Optical Spectrum Analyzer (a relatively new equipment for our students) has been more difficult to navigate in a hands-on setting than the scope.

OSA	Yes	No
1. Adjust OSA to see the signal.	25.0%	75.0%
2. Measure peak Wavelength.	83.3%	16.7%
3. Measure the line width of signals 1.	50.0%	50.0%
4. Measure the line width of signals 2.	33.3%	66.7%
5. Identify LED Vs. LD	75.0%	25.0%

Oscilloscope	Yes	No
6. Connect the laser source to the oscilloscope.	Not used	
7. Adjust the oscilloscope to see the signal.	54.5%	45.5%
8. Measure the Period.	100.0%	0.0%
9. Measure the frequency.	100.0%	0.0%
10. Measure the rise time.	58.3%	41.7%

Table 2. Student opinion on laboratory practice in the hands-on setting.

Hands-on Laboratory	YES	NO
1. Were you able to conduct the experiment?	88.9%	11.1%
2. Can you identify different connectors used?	33.3%	66.7%
3. Did you check if the bias current of the LED is set correctly?	33.3%	66.7%
4. The hands-on laboratory helped me understand the concepts better.	77.8%	22.2%
5. I was able to set up the OSA correctly to get the spectrum characteristics.	55.6%	44.4%
6. I was able to set up different wavelength ranges in the OSA.	77.8%	22.2%
7. The remote laboratory gave me similar experiment compared to hands-on experiment?	55.6%	44.4%
8. I was able to measure the output peak power after various fiber link lengths.	Not	Used

Table 3. General student opinion on the e-labs.

	Strongly Disagree	Disagree	Agree	Strongly Agree
General				
1. The remote control speed was enough to do the lab.	0%	30%	50%	20%
2. The remote control panel software was easy to use.	0%	27.3%	54.5%	18.2%
3. The instrument control was clear.	0%	30.0%	60.0%	10.0%
4. Instrument visualization was clear.	0.0%	11.1%	88.9%	0.0%
5. The remote laboratory provided a similar experience to a “hands-on” lab.	20.0%	40.0%	40.0%	0.0%
Lab 1- Free Space Experiment				
6. The laboratory improved my understanding of Free Space optics.	0.0%	50.0%	37.5%	12.5%
7. The lab manual was easy to understand.	12.5%	25.0%	62.5%	0.0%
8. The laboratory instructions were clear	0.0%	44.4%	55.6%	0.0%
9. The pre-lab was helpful in understanding and performing this lab.	0.0%	20.0%	60.0%	20.00%

Lab 2- Dispersion				
10. The laboratory improved my understanding of dispersion	0%	10.0%	90.0%	0.0%
11. The lab manual was easy to understand.	0.0%	18.2%	72.7%	9.1%
12. The laboratory instructions were clear	0.0%	27.3%	72.7%	0.0%
13. The pre-lab was helpful in understanding and performing this lab.	0.0%	18.2%	63.6%	18.2%
Lab 3- Fiber Loss Characterization				
14. My understanding fiber link loss is improved.	0.0%	20.0%	70.0%	10.0%
15. Fiber attenuation measurements were clear.	0.0%	10.0%	70.0%	2000.0 %
16. Power level after each fiber link was easy to measure.	0.0%	10.0%	80.0%	10.0%
17. The lab manual was easy to understand.	0.0%	18.2%	72.7%	9.1%
18. The laboratory instructions were clear.	0.0%	27.3%	63.6%	9.1%
19. The web interface was easy to follow and understand.	0.0%	11.1%	77.8%	11.1%
20. The pre-lab was helpful in understanding and performing this lab.	0.0%	10.0%	70.0%	20.0%
Lab 4- Optical light source characterization				
21. The laboratory improved my understanding of LEDs.	0.0%	22.2%	66.7%	11.1%
22. The laboratory improved my understanding of laser.	0.0%	22.2%	66.7%	11.1%
23. Wavelength ranges were easy to set and observe.	0.0%	33.3%	66.7%	0.0%
24. The lab manual was easy to understand.	0.0%	10.0%	80.0%	10.0%
25. The laboratory instructions were clear.	10.0%	10.0%	70.0%	10.0%
26. The web interface was easy to follow and understand.	0.0%	11.1%	88.9%	0.0%
27. The pre-lab was helpful in understanding and performing this lab.	0.0%	11.1%	77.8%	11.1%
Lab 5- Optical detector characterization				
28. The laboratory improved my understanding of optical detector.	0.0%	37.5%	50.0%	12.5%
29. The lab manual was easy to understand.	0.0%	11.1%	88.9%	0.0%
30. The laboratory instructions were clear.	12.5%	25.0%	62.5%	0.0%
31. The web interface was easy to follow and understand.	0.0%	25.0%	75.0%	0.0%
32. The pre-lab was helpful in understanding and performing this lab.	0.0%	25.0%	50.0%	25.0%

5. Lessons Learned

One of our research questions is how to map an optical concept into remote experiment and a simulation. Given the complexity of manipulating optical equipment, the remote lab concepts had to be simplified in order to cover both instrument usage and the optical concepts. This simplification approach led to sometimes oversimplified laboratories. However, signal processing exercises help students get into system analysis. We have observed that students need to tweak and play with the observation instrument more than they would otherwise in order to get used to the remote lab concept. And then, they can concentrate on the concept of interest for the experiment. Since the only interface for the student to the lab is the instrument (as opposed to the setup and details of equipment), the available controls to the instrument had to be limited for a more focused laboratory experiment. This work has been published and presented in [2].

The teaching imperfections and technology imperfections have been identified and presented [3]. Although the connection speed to the main server has been fast, the connection speed between the equipment and the data acquisition software has been challenging to adjust for a real-time view. It is still not the same as the real-time view. Getting adjusted to this view contributes to better understanding of the concept for the students. Another technology imperfection has been in the area of number of controls that we can provide to the students on the instruments. The number of controls had to be sufficient enough to relay the concept while they also had to be as few as possible in order to prevent confusion. Teaching imperfections appeared in the way online material had to be presented. As opposed to the interaction with an instructor, the students had to interact with the web pages to find their way in the system of lab manuals, entry mechanisms, remote lab connections, and simulation screens. The web site of the project helped to put things into place at the University of Houston.

One of the main concerns in our work was the connection speed that the students would have for these experiments. We have not had any student connecting to the labs through a dial-up line, all were broadband connections. This finding proved that we can include many inline image/video/audio, that is, multimedia, to enhance the teaching methods.

The students will need a video orientation to the setup for every lab in order to have a feeling on the equipment that they are trying to access through the interface. And, video orientation mechanisms have not been invested in well enough on the University of Houston side to answer this need in a timely manner. We have experimented with a hand-held camera, a Polycom stationary equipment, and an IP webcam. The best approach should have a flexible angle of view for the instructor to both show the equipment and also explain the details of the setup. Otherwise, students did not have any notion of the equipment that they have interacted with. The university of Colorado collaborators developed a solution based on Tegrity software. That solution is more promising as it integrate slides, audio and video presentations. The team is investigating the proper technique to solve this issue as it will form the basis of modular lecture development that can be utilized by different institution. This issue will be investigated in phase 2 of the project.

Optical circuits labs accessed in a remote fashion will not be able to convey a troubleshooting experience. Therefore, they need to be enhanced by a complicated set of simulations. Students should be involved in the development of the simulation software to feel the signal processing and system perspective. The simulations in our first proposal have been directed towards showing ideal cases with emphasis on concepts that cannot be demonstrated on the remote lab setting. In addition to this goal, we have decided to include more interaction in the simulations towards a better understanding of the concepts.

Modularity is very important for lab components to be utilized by different institutions. A laboratory experiment should be as self contained as possible. For a laboratory to be utilized by others, it should include a video orientation, video demonstration of how the experiment is set up, Video presentation for the simulation part, and possible slide presentation of related concept.

6. Conclusion

Developing online laboratory is of critical importance to distance education. This project contributed within the field by the following:

1. Developing a method to map an experiment into remotely controlled one that is accessed through the Internet.
2. Identifying the teaching imperfections versus technology imperfections and how researcher/teacher should deal with them.
3. Developing an online lab model (pre-lab using simulation, video orientation, remote-control lab) that provides modularity and enables resource sharing among multiple institutions.

Appendix

University of Houston
College of Technology
Computer Engineering Technology and Electrical Power Technology

ELET 4398 Optical Circuits

Experiment 5: Optical Detector Characterization

1 Purpose

The purpose of this experiment is to investigate the optical detectors and their operation of converting an optical signal into an electrical one.

2 Objectives

At the end of this experiment you will be able to state a couple of the characteristics of optical detectors. One of them is their sensitivity on the wavelength and the other is on their responsivity.

3 Equipment, Components and Simulation Software

For this experiment, the student will need the following:

- VPIPlayer simulation software
- Pulse modulated optical source(s)
- Wideband photodiode receiver
- Oscilloscope's photodetector

4 Pre-Lab

4.1 Principles of Optical Detection

External photo-electric effect is one way of detecting an optical signal: electrons are freed from the surface of a metal by the energy absorbed from the incident stream of photons [1]. An internal photoelectric effect in semiconductor junction devices is used to detect the optical signal. The common semiconductor devices using this mechanism are:

- pn junction photodiode
- PIN photodiode
- avalanche photodiode

The most important detector properties are

- Responsivity
- Spectral response
- Rise time

Example photodetector data sheet is shown in Fig. 1 below. The responsivity of this photodetector is 0.21 A/W during typical operation for $\lambda = 436$ nm. The rise time at $\lambda = 820$ nm at a load resistance of 50 Ω .

Silicon Photodetector

Series 5T

Electrical / Optical Specifications

Characteristics measured at 22°C (±2) ambient, and a reverse bias of 12 volts, unless otherwise stated. Shunt Resistance measured at ± 10mV.

For rise time on Quadrants, Linear and Matrix Arrays take figures for single element diodes having equivalent active area.

Single Elements

Type No.	Active Area		Responsivity A/W $\lambda = 436\text{nm}$		Dark Current (nA)		NEP $\text{WHz}^{-1/2}$ $\lambda = 436\text{nm}$ $V_r = 0\text{V}$ Typ.	Capacitance pF		Shunt Resistance Megohms		Risetime ns $\lambda = 820\text{nm}$ $R_L = 50\ \Omega$ Typ.	Package
	mm^2	mm	Min.	Typ.	Max.	Typ.		$V_r = 0\text{V}$ Max.	$V_r = 12\text{V}$ Max.	Min.	Typ.		
OSD1-5T	1	1.13 dia	0.18	0.21	1	0.2	2.5×10^{-14}	35	7	250	1000	7	TO18
OSD3-5T	3	2.16 x 1.4	0.18	0.21	2	0.5	3.0×10^{-14}	80	20	100	700	9	TO18
OSD5-5T	5	2.52 dia	0.18	0.21	2	0.5	3.3×10^{-14}	130	35	100	600	9	TO5
OSD7.5-5T	7.5	2.75 x 2.75	0.18	0.21	3	1	4.6×10^{-14}	180	40	60	300	10	TO5
OSD15-5T	15	3.8 x 3.8	0.18	0.21	5	1	5.5×10^{-14}	390	80	50	200	12	TO5
OSD35-5T	35	5.9 x 5.9	0.18	0.21	10	2	7.5×10^{-14}	950	200	20	100	20	TO8
OSD50-5T	50	7.98 dia	0.18	0.21	15	5	1.6×10^{-13}	1300	270	5	25	26	TO8
OSD60-5T	62	7.9 x 7.9	0.18	0.21	25	6	2.3×10^{-13}	1800	310	3	12	30	TO8
OSD100-5T	100	11.3 dia	0.18	0.21	30	8	2.1×10^{-13}	2500	520	2	15	45	13
OSD300-5T	300	19.54 dia	0.18	0.21	200	30	3.5×10^{-13}	7500	1500	1	5	125	15

Quadrants

(Values given are per element unless otherwise stated)

Type No.	Active Area (Total)			Responsivity A/W $\lambda = 436\text{nm}$		Dark Current nA		NEP $\text{WHz}^{-1/2}$ $\lambda = 436\text{nm}$ $V_r = 0\text{V}$ Typ.	Capacitance pF		Shunt Resistance Megohms		Crosstalk% $\lambda = 900\text{nm}$		Package
	mm^2	mm	Sep. mm	Min.	Typ.	Max.	Typ.		$V_r = 0\text{V}$ Max.	$V_r = 12\text{V}$ Max.	Min.	Typ.	Max.	Typ.	
QD7-5T	7	2.99 dia	0.2	0.18	0.21	6	2	2.3×10^{-14}	50	15	80	1200	5	1	TO5
QD50-5T	50	7.98 dia	0.2	0.18	0.21	30	3	4.6×10^{-14}	330	80	10	300	5	1	10
QD100-5T	100	11.3 dia	0.2	0.15	0.18	50	5	7.0×10^{-14}	650	130	5	100	5	1	11

Fig. 1. Optical and Electrical Specifications of a photodetector is shown in this data sheet (<http://www.msc-ge.com/download/Centric/fotodet/EOSeries5T.pdf>)

4.2 Responsivity

The responsivity is the ratio of the output current (generated by the electrons that absorbed the energy of the photons) through a load resistance to the optical input power. Therefore, the unit of this property is in amperes/watt.

$$\rho = \text{current (i)} / \text{power (P)}$$

4.3 Spectral Response

The responsivity of the detector changes by the wavelength of the incident optical signal on the detector. The spectral response measures this variation due the wavelength. An example variation from the same data sheet is included in Fig. 2.

Series 5T –Typical Spectral Response

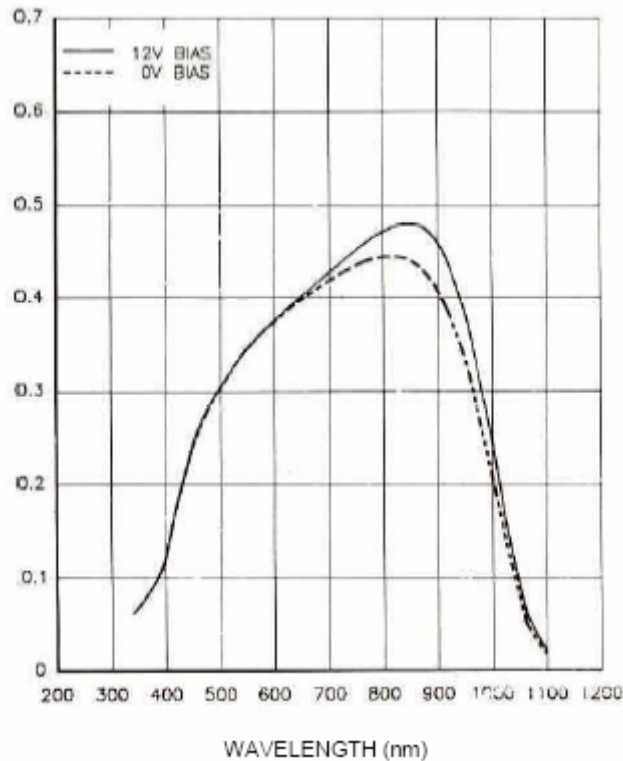

Fig. 2. Spectral response curve from a sample data sheet. (<http://www.msc-ge.com/download/Centronic/fotodet/EOSeries5T.pdf>)

As you can see from Fig. 2, the maximum responsivity (max. current/voltage generated for the same amount (number) of photons hitting the surface of the detector happens around 800-900 nm range. And, the curve does not exhibit a linear characteristic. During the design and implementation of systems, this characteristic of the detectors should be taken into account for better predictability of resulting electrical signals.

4.4 Rise Time

The rise time measures the time it takes for the detector output current to change from 10% to 90% of its final value while the input optical signal varies in a perfect step from zero power to its high power level. Since the rise time will contribute to the eye closure of the signal at the detection end, the modulation bandwidth of the detector is limited:

$$f_{3-dB} = \frac{0.35}{t_r}$$

The detector would be able to perform an acceptable opto-electrical conversion if the input signal is at a bit rate equal or lower than the modulation bandwidth. In addition, the electrical signal power at the detector output is half of the optical power incident on the detector.

4.5 Simulation Lab

In this step you will simulate optical signal detection of two sources at different wavelengths in order to demonstrate the wavelength dependency of detection responsivity. Our simulation tool is called VPI Player. You need to download the free VPI Player from VPI systems web site at <http://www.vpi Photonics.com/VPIplayer.php>.

5 Experiment

In this experiment, you will be presented with the output of two different detectors. The input wavelength/laser is same for both.

5.1 Setup

The MM laser source has been modulated using an optical modulator around 4 MHz. This corresponds to a period of 250 nsec (each pulse will be 125 nsec for RZ modulation format).

The setup of this experiment is displayed in the figure below. There are two detectors that detect the optical signal.

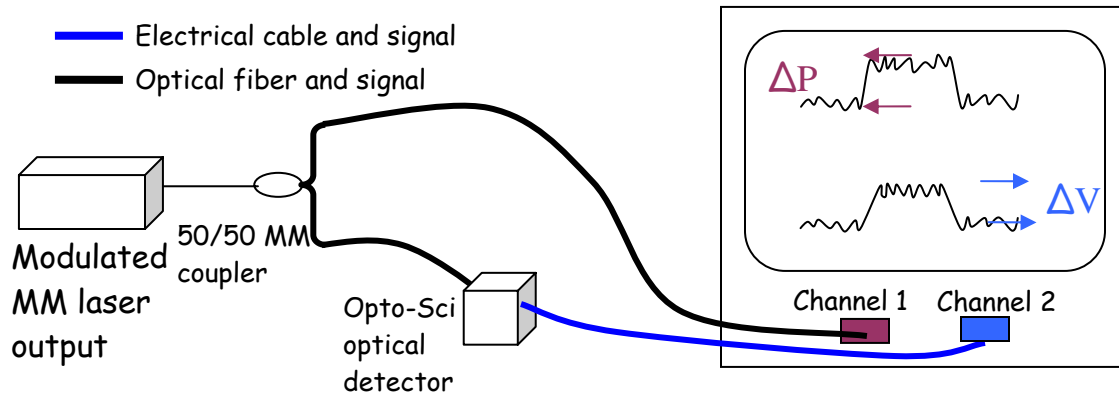

Fig. 3. The setup of the experiment includes 2 detectors receiving the same amount of optical power from the laser.

The Fig. 3 depicts the fact that one channel will read optical power and the other will read the voltage from their inputs. You will need to convert these into their corresponding voltages.

5.2 Procedures

Assume that both detectors are displaying the voltage through a resistor of 50Ω for simplicity.

1. Determine the responsivity of each detector.
2. Check the data sheet of the detector on the scope by connecting to the company web site for the Tektronix CSA 7404 scope. Retrieve the detector characteristics to determine the posted specifications on the responsivity of this detector. Compare with what you have determined from this experiment.

References

- [1] Alexander Waskiewicz, Alan Mickelson, Driss Benhaddou, and Deniz Gurkan, "A two credit hour stand alone remote optics laboratory," abstract accepted to ASEE 2007.
- [2] Driss Benhaddou, Deniz Gurkan, Harshita Kodali, Ed McKenna, Alan Mickelson and Frank Barnes, "Online Laboratory for Optical Circuits Courses: Effective Concept Mapping," in Proceedings of the 2006 ASEE Gulf-Southwest Annual Conference, 2006.
- [3] Richard Franzl, Deniz Gurkan, Driss Benhaddou and Alan Mickelson, "E-Learning Laboratories for Optical Circuits: Separation of Imperfections in Technology and Teaching Methodologies," in Proceedings of The 2006 IJME – INTERTECH Conference, 2006.