



Outcomes of Using an Infinitely Explorable Online Learning System

Dr. Franco Capaldi, Merrimack College

Prof. Devin R. Berg, University of Wisconsin - Stout

Devin Berg is an assistant professor in the Engineering and Technology Department at the University of Wisconsin - Stout. His research interests are in the areas of engineering education and the design of medical devices.

Outcomes of Using an Infinitely Explorable Online Learning System

Introduction

The use of online educational software has seen tremendous growth over the past decade as institutions strive to provide quality education to a larger number of students of diverse backgrounds. This is evidenced by the proliferation of fully online degree programs that cater to students with limited access to traditional on-campus instructional resources. Additionally, an increasing number of traditional classrooms are using online educational software to supplement standard teaching practices in order to better match the diversity of students' learning styles without straining limited instructional time and resources¹. This trend signals a disruptive shift in the manner in which education is delivered. Despite this, it has been found that engineering programs have adapted to online educational methods at a significantly lower rate than other discipline areas². This may be attributed to the deficiencies of existing online learning systems including 1) constraining student responses to quantities the system explicitly asks for, 2) constraining the way in which students must enter their answers, and 3) an inability to discern the incorrect components of a student's answer.

A next generation online learning system has been developed at Merrimack College with the goal of revolutionizing online engineering education by "understanding a subject" rather than simply delivering content. The software delivers content in an interactive, three-dimensional environment as shown in Figures 1 and 2. When presented with a problem, student input is not constrained in format or to only the final solution. Students have the ability to enter equations, diagrams, graphs, or text related to any portion of the problem including the solution, intermediate steps, or even extraneous aspects of the problem. These entries are evaluated by the software and feedback is provided regarding the correctness of the entry in the context of the presented problem. This grants the student freedom to explore the problem and receive instantaneous feedback as though they were interacting with the instructor in real-time. A number of studies have found that students provided with immediate feedback when working problems are more actively engaged in the learning process and demonstrate greater retention of the information^{3,4,5}. This feedback can take the form of either standard correct/incorrect responses or an answer-until-correct approach. However, some evidence suggests that the answer-until-correct approach has a more significant impact on information retention⁶. Further, the use of immediate feedback in the setting of the online educational software allows the student to experience a learning environment more consistent with that of individual instruction while not requiring the direct input of the instructor.

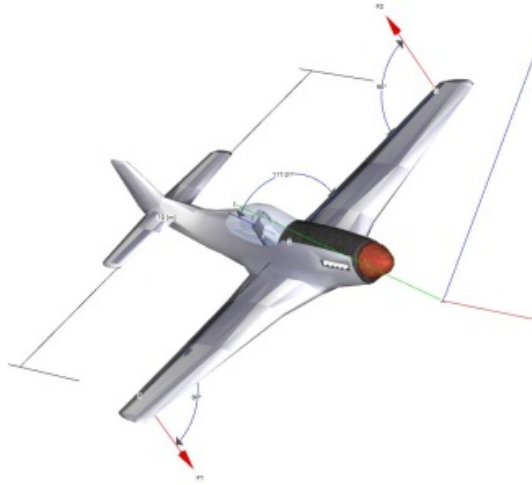

Figure 1. Example of free body diagram in software.

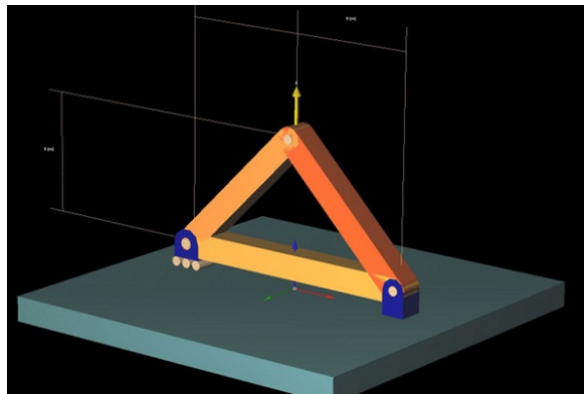

Figure 2. Example of software model.

Additionally, it has been demonstrated that students perform better on assessments when using an inquiry based or active learning method during preparation^{7,8}. The approach of this method is to present the student with a problem and allow them to explore the problem by asking questions and learning from the answers to those questions. This represents a form of discovery based learning but with more direction since the software leads the student towards the desired solution, similar to the guided inquiry method⁹. Through these methods, students engage higher-order thinking tasks which in turn promote stronger development of necessary problem solving skills¹⁰. Students who learn by these methods have been found to have better overall achievement as well as improved critical thinking skills⁹. These skills thus better prepare the student for life-long learning when compared against a traditional lecture-only approach. By employing a combination of these methods and allowing students to interact with problems in a fully three-dimensional environment, it is hypothesized that students will be able to construct knowledge through exploration and experimentation in the context of the engineering problems contained within the software.

It is clear that the aforementioned mechanisms for educational practice have proven effective in the engineering classroom when compared against a more traditional approach. However, it is not clear that these methods will prove as effective when employed in the setting of an online educational software. In this paper, results of a pilot study on the effectiveness of this new online learning system will be presented. The specific aims of this study include:

- 1) Test the effectiveness of using this software in enhancing learning in engineering courses.
- 2) Evaluate the underlying mechanisms used in the software (active learning, immediate feedback, and an interactive three-dimensional environment).
- 3) Study the usage scenarios when students are allowed to use the software with little instruction.

The Sigma Grading System (SGS) has several features which enable students to explore engineering problems and engineering topics. These include the following: 1) a flexible interpreter with immediate feedback, 2) an equation to word converter, 3) electronic paper, and 4) a flexible free body diagram interpreter.

Flexible Interpreter with Immediate Feedback

Building on a fast, flexible mathematical interpreter, the software can interpret the validity of mathematical statements. A user is free to evaluate a variety of statements using numerical or symbolic variables as shown in Figure 3. The equation is checked for unit consistency, notation, and significant figures. In the example in Figure 3, θ and β are complimentary angles. As such, a student may enter $\theta + \beta = \frac{\pi}{2}$ [*radians*] or $\theta + \beta = 90$ [*degrees*]. Both are marked as correct. They can also enter $\sin \theta = \cos \beta$ and receive feedback on this statement. As long as students are using symbols or values in the problem, they can test any mathematical statements for correctness. If they do not know the final answer, they can test an intermediate step.

Students are often frustrated if software cannot distinguish between various correct equations. The flexibility built into the SGS is designed to overcome this limitation by recognizing such variations as is indicated by the blue check marks in the margin to the left of the equations (see Figure 3).

Sample question.

Question 1/1 Assignment Grade 0%

Score 0/100

Given the right triangle ABC shown in the figure,

- find θ .
- find β .
- find d .

Submit

<input checked="" type="checkbox"/>	$\theta + \beta = \pi/2$	Incorrect. Check your units.
<input checked="" type="checkbox"/>	$\theta + \beta = 1.6$ [radians]	Incorrect. You must use 3 significant figures. You have 2.
<input checked="" type="checkbox"/>	$\theta + \beta = \pi/2$ [radians]	
<input checked="" type="checkbox"/>	$\theta + \beta = 1.57$ [radians]	
<input checked="" type="checkbox"/>	$\sin(\theta) = \sin(\beta)$	Incorrect. Incorrect.
<input checked="" type="checkbox"/>	$\sin(\theta) = \cos(\beta)$	

Figure 3. Example of student entry in software.

The system is also capable of interpreting vector notation. The screenshot shown in Figure 4 illustrates the use of vector notation. The vector $\vec{r}_{A/D} = -25i + 48j + 36k$ [in] represents the position vector connecting points D and A. The system can be taught to recognize subject specific notation such that meaningful equations may be formed. Similarly, the system can interpret unit vectors, tensions, moments, and a range of other subject specific notation.

<input checked="" type="checkbox"/>	$\vec{r}_{A/D} = -25i + 48j + 36k$ [in]	
<input checked="" type="checkbox"/>	$T_{AD} = 533.7$ [N]	
<input checked="" type="checkbox"/>	$\vec{r}_{A/D} = -25i + 48j + 36k$ [in]	
<input checked="" type="checkbox"/>	$\vec{r}_{A/D} = -25i + 48j + 36k$ [in]	
<input checked="" type="checkbox"/>	$\hat{e}_{A/D} = -0.385i + 0.738j + 0.554k$	
<input checked="" type="checkbox"/>	T_{AB}	

Figure 4. Example of equation entry using vector notation.

Equation to Word Converter

Students learning a new topic are often confused by the notation. They do not always realize what their equations represent. Because of this, the SGS has an equation to word converter. The equation

$$\vec{r}_{A/D} = -25 i [in]$$

Is converted to:

“The position vector from point D to point A is equal to the negative of the scalar value 25 multiplied by the unit vector i with units of inches”.

This conversion can be executed on any mathematical statement input by the user. If the equation is marked as incorrect, the student can read the interpretation to more easily spot their error.

Electronic Paper

Students have access to equation entry, diagram entry, and text entry for each problem. Therefore, they can form proper solutions to engineering problems which include text descriptions. While the text shown in Figure 5 is elementary, the text entry boxes can be used for any amount of text and can be included between equations or diagram entries. The instructor has full access to each student’s entries and can critique a student’s solution.

Question 1/3 Assignment Grade 0%

Score 0/33.3

Given the following equation:
 $4.178 + -2.69x = 81.11$

a) Solve for x.

√ T Submit





	<i>Subtract 4.178 from both sides</i>	
	$-2.69 * x = 76.93$	
	<i>Divide both sides by -2.69</i>	
	$x = (81.11 - 4.178) / (-2.69)$	
	$x = -1.0 * (76.93 / 2.69)$	
	<i>Left out a negative sign</i>	
	$x = 28.6$	Incorrect. Check your signs.
	$x = -28.6$	

Figure 5. Example of text entry.

Flexible Free Body Diagram Editor

Keeping with the intent of allowing flexible student entry, the system allows students to draw a free body diagram of a system. If we assume that the system consists of a truss as shown in Figure 6, the student is free to draw any free body diagram they would like of the system. For example, they might select a particular bar within the system, Figure 6b, or they might decide to create a control volume and draw a free body diagram of this, Figure 6c. The system interprets the free body diagram to ensure that the forces have been properly placed in the system and flags any missing or incorrect forces as appropriate.

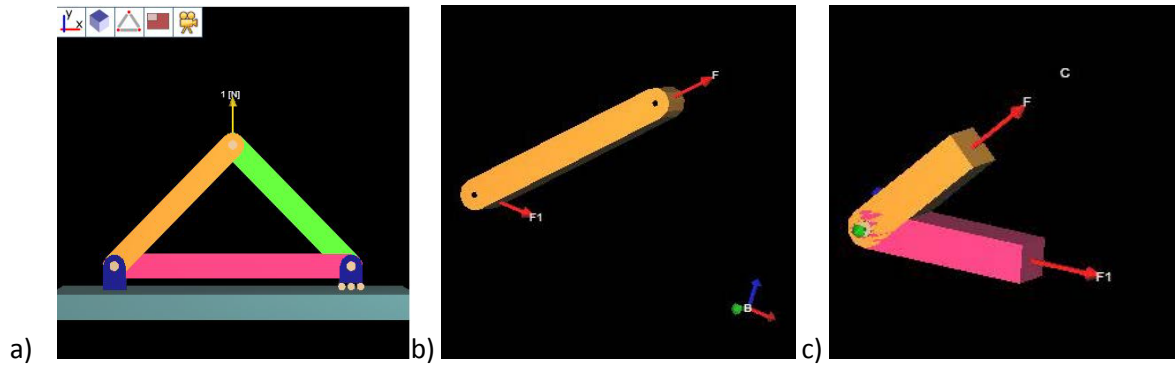

Figure 6. (a) Sample truss system, (b) a free body diagram of a single bar within the system (incorrect forces are flagged by the system), (c) partial free body diagram illustrating a cut made through two bars missing reaction forces are flagged by the system.

Methodology

The study presented in this paper was conducted at Merrimack College and the University of Wisconsin – Stout to evaluate the effectiveness of the system. The study consisted of both control groups and treated groups at each school, split according to course section assignments. The treated group used the online learning system and the control group was given traditional written assignments and activities. The Force Concept Inventory (FCI)^{11,12} was administered for all groups prior to treatment, allowing for a clear comparison between the two groups initial level. The outcomes of each student group’s performance on identical exams throughout the term are presented for students at Merrimack College. Exam content matched material covered during the semester for both the control and treatments groups. Additionally, pre- and post-FCI results for students at UW – Stout are presented. Finally, the use of survey and observational components for assessment allowed us to acquire qualitative data regarding usage scenarios and acceptance of the online learning system by students.

Quantitative Evaluation

Quantitative data was collected from two groups of students taking an engineering statics course. The results gathered from both initial assessment and subsequent performance on course exams is presented in Table 1. Data is presented as average group performance for each group along with standard deviation for each average score. The results show that students in each group performed at a similar level for the initial assessment. It is apparent that for each subsequent performance evaluation, the treatment group performed at a higher level than the control group. This was the most pronounced for Midterm 2 when students were evaluated on the concepts of moments and free body diagrams. However, it should be noted that the variations between each group were not statistically significant based on the standard deviation.

Table 1: Quantitative assessment results for Merrimack College students.

Section	Initial Assessment	Midterm 1 Vectors, Forces	Midterm 2 Moments, Free body diagrams	Midterm 3 Moment of inertia, Centroids	Final Exam
Treatment Group (n=12)	31 ± 14	84 ± 19	91 ± 7	88 ± 10	87 ± 7
Control Group (n=7)	36 ± 10	74 ± 21	73 ± 13	79 ± 16	82 ± 15

Using the Force Concept Inventory, students within the treatment (n=21) and control (n=23) groups of an engineering mechanics course at UW – Stout were evaluated both prior to treatment and after treatment. The results of this evaluation were interpreted based on the gain for each student as a percentage of maximum possible gain¹³. This metric allows for a more independent analysis among “weaker” and “stronger” students.

The results of this interpretation showed that for the treatment group the average gain was 14.0 % (22.1 % if considering only students with positive net change). Similarly, for the control group the average gain was 5.8 % (15.6 % if considering only students with positive net change). This result is represented graphically in Figure 7. Sub-figure (a) shows the plot of post- versus pre-test scores for the treatment group while sub-figure (b) presents the same for the control group. Each data point represents a student’s pair of scores while the line corresponds with no change in score. The further a data point is from the line, the larger the gain in that student’s score. It is apparent that for the treatment group, larger gains were realized for students spanning from the lowest scoring students to the highest. For the control group, the majority of the large gains were observed with the “weaker” students while the higher performing students actually scored the same or worse on the post-test. These results would seem to suggest that the use of the system benefited a wider selection of the students in the group while the more traditional approach showed greater gains for the “weaker” students with a possible negative impact on the “stronger” students.

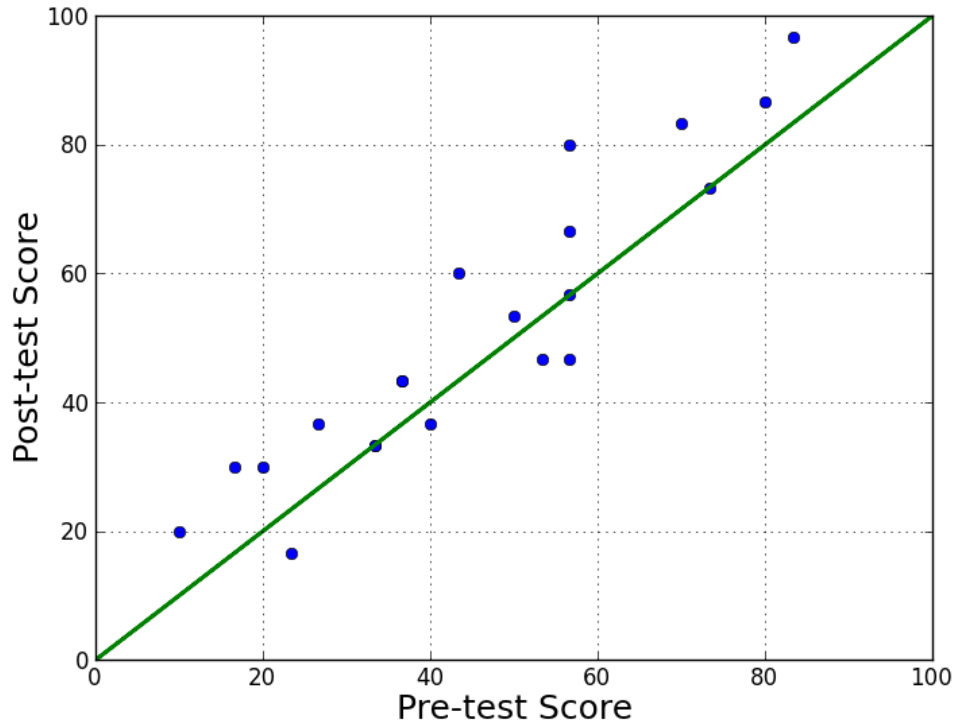

(a)

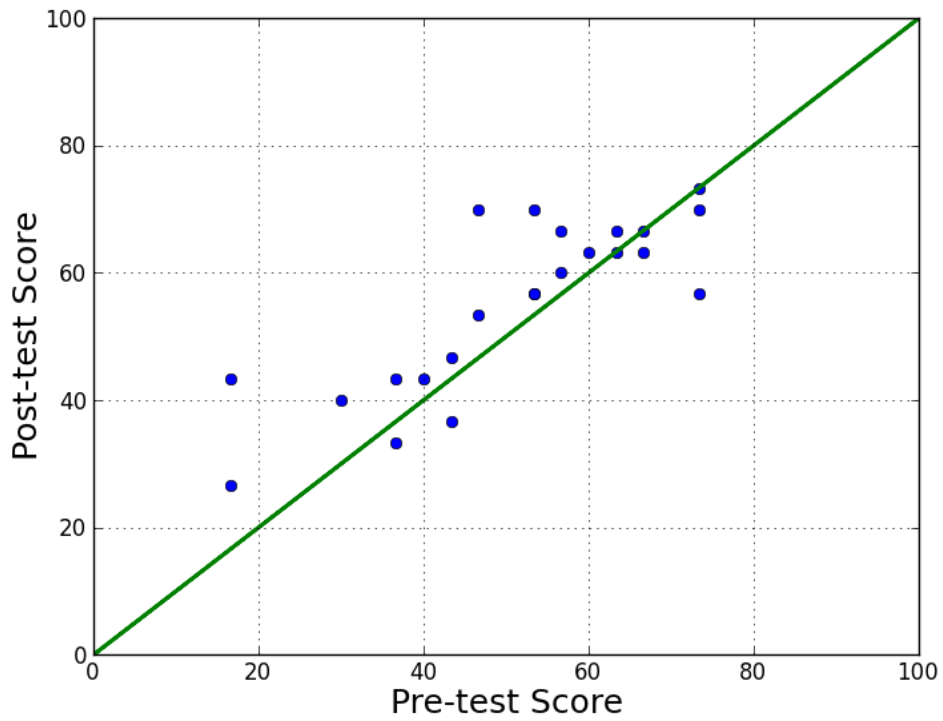

(b)

Figure 7. Pre- and post-FCI results for both (a) the treatment group (n=21) and (b) the control group (n=23).

Observational Comments

There were three main observational results: 1) students must be taught to test intermediate steps or hypotheses, 2) interface design is critical, and 3) an adaptive algorithm is needed to enhance user interaction.

First and foremost, students are not familiar with the concept of hypothesis testing. Other online systems / assignments penalize students for making incorrect statements and do not allow for students to enter intermediate steps. Because of this, they do not fully engage with the system on their own. There are two strategies being considered to remedy this problem. First, grading based on the number of intermediate steps entered (which incentivizes the entry of intermediate steps) and adding additional training and help modules within the program.

Second, interface design is critical. Students are accustomed to having instant response in their internet and mobile applications. A slow response when first utilizing the system frustrated the students. In addition, engineering notation is very specific (e.g. vector notation, significant figures, etc.). Students learning the “language” of engineering are often frustrated because they do not understand the large differences in meaning due to small differences in notation. In this respect, the software performed very well. At Merrimack College, using the software system promoted a better understanding of the engineering notation used in the class. It is the instructor’s impression that this better use of the engineering notation and a better understanding of the meaning of the notation may be responsible for the entire difference in performance between the treatment and control groups.

Third, an adaptive algorithm is needed to enhance user interaction. Due to the wide disparity in terms of student preparedness, students must be able to “catch up”. Currently, adaptive algorithms are being implemented that will identify areas of student weakness and provide appropriate material to improve the student’s understanding in these areas.

Summary

Students in the treatment group at Merrimack College consistently outperformed students in the control group. Part of this seems to be due to a better adherence and understanding of the engineering notation. Additionally, students in the treatment group at UW – Stout displayed a higher level of improvement across the range of abilities when compared with the control group. This might be attributed to the system’s ability to present a problem in multiple ways and thus better reach students of varying learning styles. Finally, feedback gathered from students in the treatment groups suggests that the most significant benefit provided by the software was the ability to interact with problems in a three-dimensional environment and explore problem geometry. This result is particularly true for problems involving three-dimensional vectors or problems with complicated geometry. Further, the students who made use of the software’s ability to evaluate intermediate steps in the problem solution found this feature incredibly helpful for difficult engineering problems. The results presented here indicated a positive correlation between exposure to the grading system and course performance. This outcome is promising and demonstrates the need for further experimentation to achieve greater confidence.

To ensure success of the software and facilitate greater acceptance by students there are several areas for possible improvement. Students often struggled with the input formatting expected by the software. Therefore, care will be taken to both better educate students on proper formatting through usage tutorials and lower the barrier of entry for using the software by making it interpret student input more robustly. Education of students on software usage is particularly important because the software behaves differently from other similar software packages and students were found to have difficulty adapting to these differences. Additionally, future revisions of the software will improve user interaction and focus on the automatic identification of student weakness.

Bibliography

- [1] Lage, M.J., Platt, G.J., and Treglia, M., 2000, "Inverting the Classroom: A Gateway to Creating an Inclusive Learning Environment," *The Journal of Economic Education*, 31(1), pp. 30-43.
- [2] Allen, I.E. and Seaman, J., 2008, "Staying the Course: Online Education in the United States, 2009," *Babson Survey Research Group: The Sloan Consortium*.
- [3] Epstein, M.L., Lazarus, A.D., Calvano, T.B., Matthews, K.A., Hendel, R.A., Epstein, B.B., and Brosvic, G.M., 2002, "Immediate Feedback Assessment Technique Promotes Learning and Corrects Inaccurate First Responses," *The Psychological Record*, 52(2), pp. 187-201.
- [4] Dihoff, R.E., Brosvic, G.M., and Epstein, M.L., 2004, "Provision of Feedback Preparation for Academic Testing: Learning is Enhanced by Immediate But Not Delayed Feedback," *The Psychological Record*, 54(2), pp. 207-232.
- [5] Hattie, J. and Timperley, H., 2007, "The Power of Feedback," *Review of Educational Research*, 77(1), pp. 81-112.
- [6] Butler, A.C., Karpicke, J.D., and Roediger III, H.L., 2008, "Correcting a Metacognitive Error: Feedback Increases Retention of Low-Confidence Correct Responses," *Journal of Experimental Psychology: Learning, Memory, and Cognition*, 34(4), pp. 918-928.
- [7] Prince, M., 2004, "Does Active Learning Work? A Review of the Research," *Journal of Engineering Education*, 93(3), pp. 223-231.
- [8] Haury, D.L., 1993, "Teaching Science through Inquiry," *ERIC/CSMEE Digest*, ERIC Clearinghouse for Science, Mathematics, and Environmental Education, Columbus, OH.
- [9] Prince, M.J. and Felder, R.M., 2006, "Inductive Teaching and Learning Methods: Definitions, Comparisons, and Research Bases," *Journal of Engineering Education*, 95(2), pp. 123-138.
- [10] Bonwell, C.C. and Eison, J.A., 1991, "Active Learning: Creating Excitement in the Classroom," *ERIC Digest*, ERIC Clearinghouse on Higher Education, Washington, DC.
- [11] "FCI and MBT," *American Modeling Teachers Association*, Retrieved: 21 August 2012, <<http://modelinginstruction.org/researchers/evaluation-instruments/fci-and-mbt/>>.
- [12] Hestenes, D., Wells, M., and Swackhamer, G., 1992, "Force Concept Inventory," *The Physics Teacher*, 30, pp. 141-158.
- [13] Hestenes, D. and Halloun, I., 1995, "Interpreting the Force Concept Inventory: A response to Huffman and Heller," *The Physics Teacher*, 33, pp. 502-506.