

# Solving Beam Deflection Problems using a Tradition Approach

**Joseph J. Rencis/Hartley T. Grandin, Jr.**  
**University of Arkansas/Worcester Polytechnic Institute**

## Abstract

This paper presents a new approach to solving beam deflection problems. The approach involves the direct application of derived force-deformation formulas, a procedure commonly used with axial and torsion bar problems. This direct application of derived force-deformation formulas, referred to by the authors as Method of Segments, is extended to beam deflection analysis in order to provide a solution procedure for beams that is consistent in philosophy and application with that presented in most mechanics of materials textbooks for axially loaded bars and torsionally loaded shafts. The beam force-deformation formulas, involving slope and displacement, are derived by double integration for a beam of uniform cross-section, material and distributed loading with end shear forces and couples. Application of the formulas is direct and requires no integration or continuity equations. Furthermore, by identifying segments of uniform geometry, material and distributed loading, this approach can easily be applied to beams of discontinuous geometry and material that supports both concentrated and distributed loading.

## Introduction

The great majority of undergraduate mechanics of materials textbooks<sup>1-50</sup> directly apply previously derived force-deformation formulas to problems involving the straight bar subjected to centric axial loading and the straight circular cross-section bar (shaft) subjected to twisting couples. In both cases, the bars are uniform in cross-section and material, and the concentrated loads are applied at the ends and distributed loads are continuous along the full length. The force-deformation formulas are shown in Figures 1 and 2 for bars subjected to centric axial loading and twisting couples, respectively. These formulas, referred to as Material Law Formulas by the authors, are commonly found in mechanics of materials textbooks<sup>1-50</sup>.

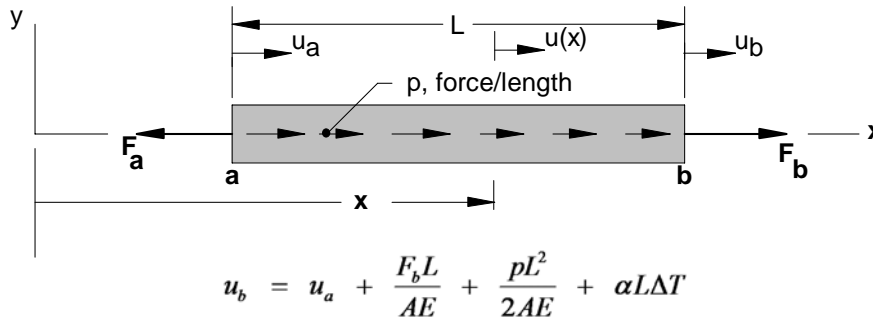

Figure 1. Material Law Formulas for a uniform bar with end centric axial and centric uniform distributed loads plus temperature change.

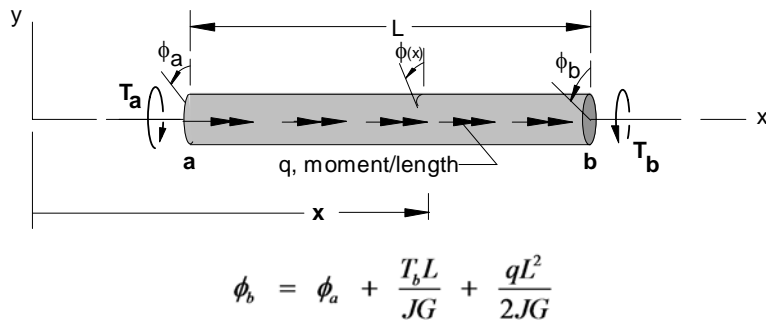

Figure 2. Material Law Formulas for a uniform shaft with end torsional couples and uniform distributed torsional couple.

In a real application, an axially loaded bar, for example, the bar may have any combination of cross section size and shape, material and applied concentrated or distributed loadings. Figure 3 illustrates a ‘complex’ bar which has two lengths of different, but individually continuous, cross-sections, loading and, perhaps, material. This bar of discontinuous cross-section, load and material can be treated as an assemblage of two simpler bars, called segments, of uniform cross-section with continuous loading along each length of uniform material as shown in Figures 3b and 3c. The effects of the loading on each segment can be combined to obtain the resultant effect on the total, more complex composite bar. Solutions are obtained by application of point compatibility and a summation of the relative displacements of the simple bar segments. The method to solve this type of problem is referred to by the authors as the Method of Segments. In mechanics of materials textbooks, the method is applied to the axially loaded bar and torsionally loaded shaft, but not the beam. The procedure is referred to as the discrete element method by Bauld<sup>1</sup>. Other textbooks do not explicitly call it a method, but the segments are referred to as component parts or portions<sup>2,3</sup>, elements<sup>9,20,27-29</sup>, parts<sup>14,15,16,22,33,47</sup>, portion<sup>6</sup>, section<sup>26</sup>, section or segment<sup>7</sup>, segment<sup>5,31,48</sup> and segment and region<sup>17,18</sup>.

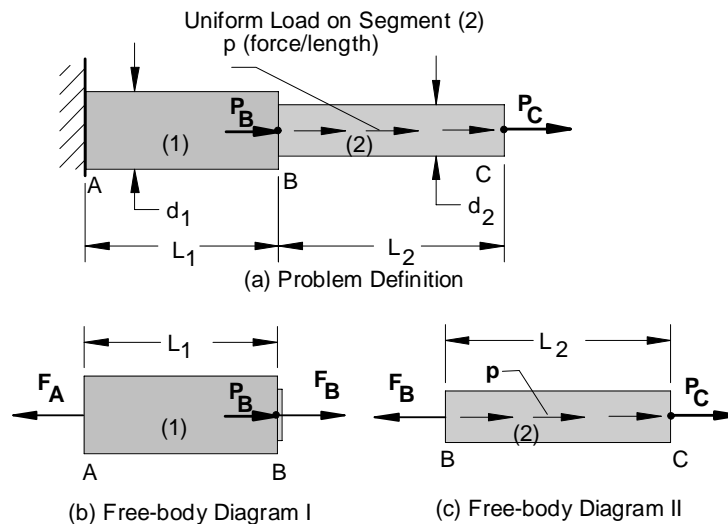

Figure 3. Two segment determinate bar problem with concentrated loads and distributed load.

The authors are not aware of any work that has used the Method of Segments to solve beam deflection problems and wish to show how this method may be used to solve beam bending problems. The Material Law Formulas for a uniform beam supporting a uniformly distributed load and end shear forces and bending couples will first be developed. The analysis process proposed by the authors to solve problems<sup>51</sup> will be discussed and will be used to solve determinate and indeterminate beam problems. A review of current beam deflection methods will be considered. Finally, the advantages and disadvantages of this proposed Method of Segments will be presented.

## Development of Beam Material Law Formulas

In this section the Material Law Formulas for a straight beam of uniform cross section and material with end and uniformly distributed transverse loading is developed using the double integration method. The double integration method is found in nearly all mechanics of materials textbooks.

Free-Body Diagram I in Figure 4 is of a linearly elastic, homogeneous (constant elastic modulus  $E$ ), beam of length  $L$ , uniform cross section (constant  $I_z$ ), with positive internal shear forces  $F_{s_A}$  and  $F_{s_B}$  and positive internal bending couples  $M_A$  and  $M_B$  acting at the ends. The beam supports a uniformly distributed downward load,  $w$ , force/length. All points in the beam, including the end points 'A' and 'B', undergo positive transverse displacement,  $v(x)$ , in the positive  $Y$  direction. At all points in the beam, including the end points 'A' and 'B', the beam neutral surface undergoes rotation  $\theta(x)$ , with the positive sense as shown in Figure 4 at the end points 'A' and 'B.' Free-Body Diagram II in Figure 4 is of the partial length of the beam produced by cutting the beam at an arbitrary location  $x$ . For this beam, the following will be derived:

- Functions defining the internal shear force,  $F_s(x) = F_{s_{AB}}$ , the internal bending couple  $M(x) = M_{AB}$ , the slope of the neutral surface (or axis),  $\theta(x) = \theta_{AB}$  and transverse displacement of the neutral surface (or axis),  $v(x) = v_{AB}$ , at any cross section location in the beam.
- Functions relating the internal shear forces  $F_{s_A}$  and  $F_{s_B}$  and bending couples  $M_A$  and  $M_B$  at the ends to the rotational and transverse displacements  $\theta_A$ ,  $\theta_B$ ,  $v_A$  and  $v_B$  at the ends.

The derivations are based on principles of equilibrium, Hooke's Law and the differential equation for beam elastic deflection  $\left( M_z = EI_z \frac{d^2v}{dx^2} \right)$ .

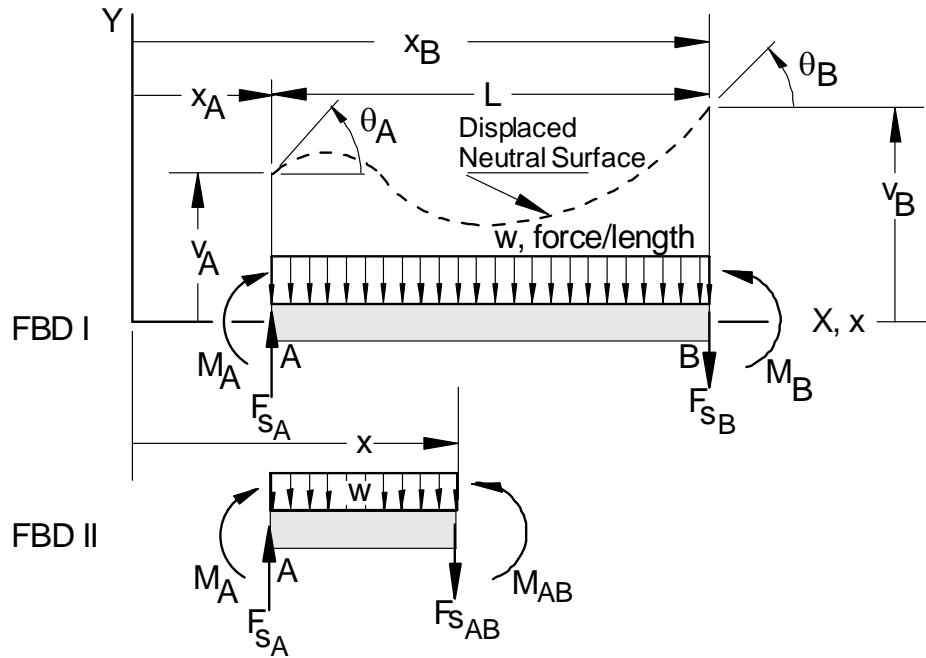

Figure 4. Uniform beam with uniformly distributed load and end shear forces and couples (positive sign convention).

- *Equilibrium Equations.* In Figure 4, equilibrium equations for FBDs I and II yield the following relationships between the shear forces and bending couples:

FBD I:

$$\sum F_Y : F_{s_A} = F_{s_B} + wL \quad (1)$$

$$\sum M_A : M_A + F_{s_B} L + \frac{wL^2}{2} = M_B \quad (2)$$

FBD II :

$$\sum F_Y : F_{s_{AB}} + w(x - x_A) = F_{s_A} \quad (3)$$

$$\sum M_{cut} : M_{AB} + \frac{w(x - x_A)^2}{2} = M_A + F_{s_A} (x - x_A) \quad (4)$$

- *Differential Equation.* Substitute Equation 4 into the differential equation for the beam elastic deflection, and integrate twice to obtain equations valid for the full beam length:

$$EI_z \frac{d^2 v}{dx^2} = M_z = M_{AB} \quad (5a)$$

$$EI_z \frac{d^2 v}{dx^2} = M_A + F_{s_A} (x - x_A) - \frac{w(x - x_A)^2}{2} \quad (5b)$$

$$EI_z \frac{d^2 v}{dx^2} dx = EI_z \frac{d\theta}{dx} dx = EI_z d\theta$$

$$EI_z d\theta = \left[ M_A + F_{s_A} (x - x_A) \right] dx - \frac{w(x - x_A)^2}{2} dx \quad (6)$$

$$EI_z \int_{\theta_A}^{\theta(x)} d\theta = \int_{x_A}^x \left[ M_A + F_{s_A} (\beta - x_A) - \frac{w(\beta - x_A)^2}{2} \right] d\beta$$

$$\theta(x) = \theta_{AB} = \theta_A + \frac{M_A}{EI_z} (x - x_A) + \frac{F_{s_A}}{2EI_z} (x - x_A)^2 - \frac{w(x - x_A)^3}{6} \quad (7)$$

$$\theta(x) dx = \frac{dv}{dx} dx = dv$$

$$dv = \theta_A dx + \frac{M_A}{EI_z} (x - x_A) dx + \frac{F_{s_A}}{2EI_z} (x - x_A)^2 dx - \frac{w(x - x_A)^3}{6EI_z} dx \quad (8)$$

$$\int_{v_A}^{v(x)} dv = \int_{x_A}^x \theta_A dx + \int_{x_A}^x \frac{M_A}{EI_z} (\beta - x_A) d\beta + \int_{x_A}^x \frac{F_{s_A}}{2EI_z} (\beta - x_A)^2 d\beta - \int_{x_A}^x \frac{w(\beta - x_A)^3}{6EI_z} d\beta \quad (9)$$

$$v(x) = v_{AB} = v_A + \theta_A (x - x_A) + \frac{M_A}{2EI_z} (x - x_A)^2 + \frac{F_{s_A}}{6EI_z} (x - x_A)^3 - \frac{w(x - x_A)^4}{24EI_z} \quad (10)$$

Substitution of  $x = x_B$  and  $L = x_B - x_A$  into Equations 7 and 10 yields the following formulas for the end  $B$  slope and transverse displacement in terms of the distributed load, the shear force and couple at end  $A$  and the slope and transverse displacement at end  $A$ :

$$\theta_B = \theta_A + \frac{M_A L}{EI_z} + \frac{F_{s_A} L^2}{2EI_z} - \frac{wL^3}{6EI_z} \quad (11)$$

$$v_B = v_A + \theta_A L + \frac{M_A L^2}{2EI_z} + \frac{F_{s_A} L^3}{6EI_z} - \frac{wL^4}{24EI_z} \quad (12)$$

It is preferable to have formulas with the dependent displacements at one end as a function of forces at the same end. In application, this would mean that the independent position variable would be the same for the displacements and forces. Substitution of Equations 1 and 2 into Equations 11 and 12 yields formulas which define the end  $B$  slope and transverse displacement in terms of the distributed load, the shear force and couple at end  $B$  and the slope and transverse displacement at end  $A$ :

$$\theta_B = \theta_A + \frac{M_B L}{EI_z} - \frac{F_{s_b} L^2}{2EI_z} - \frac{wL^3}{6EI_z} \quad (13)$$

$$v_B = v_A + \theta_A L + \frac{M_B L^2}{2EI_z} - \frac{F_{s_b} L^3}{3EI_z} - \frac{wL^4}{8EI_z} \quad (14)$$

These two formulas will be referred to as the Material Law Formulas for the end loaded beam and are presented in Figure 5 with general representative symbols 'a' and 'b'. In applying the Material Law Formulas, the symbols 'a' and 'b' are replaced by the letters assigned to the ends of each segment in the problem being analyzed. It is important to appreciate that the Material Law algebraic equations have been derived by the double integration method. Application of these formulas to any beam problem is done without the need for additional integration or solution for constants of integration.

The Material Law Formulas shown in Figure 5 is limited to a beam which has end loads, a uniformly distributed loading, uniform geometry and material for the entire beam length. We want to show how this special case can be used to solve beam problems which are complicated to the extent of having discontinuous loading functions, cross-sectional areas and materials, all in the same beam. The analysis process that will be used to solve beam problems will first be discussed and then two example problems will illustrate the application of the Material Law Formulas.

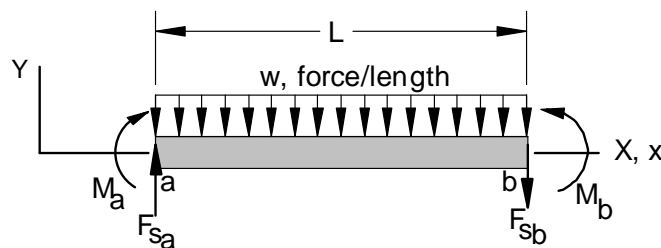

$$\theta_b = \theta_a + \frac{M_b L}{EI_z} - \frac{F_{s_b} L^2}{2EI_z} - \frac{wL^3}{6EI_z}$$

$$v_b = v_a + \theta_a L + \frac{M_b L^2}{2EI_z} - \frac{F_{s_b} L^3}{3EI_z} - \frac{wL^4}{8EI_z}$$

Figure 5. Material Law Formulas for a uniform beam with end shear forces and bending couples and uniformly distributed load.

## Analysis Process

The authors use an approach to mechanics of materials that integrates theory, analysis, verification and design<sup>51</sup>. The analysis component uses a non-traditional structured problem solving format containing eight steps. The students are required to follow the appropriate steps listed below to solve any problem.

1. *Model*. The success of any analysis is highly dependent on the validity and appropriateness of the model used to predict and analyze its behavior in a real system, whether centric axial loading, torsion, bending or a combination of the above. Assumptions and limitations need also be stated. This step is not explicitly emphasized in any mechanics of materials textbook.
2. *Free-Body Diagrams*. This step is where all the free-body diagrams initially thought to be required for the solution are drawn. The free-body diagrams include the complete structure and/or parts of the structure. Very importantly, all dimensions and loads, even those which are known, are defined symbolically.
3. *Equilibrium Equations*. The equilibrium equations for each free-body diagram required for a solution are written. All equations are formulated symbolically. There is no attempt made at this point to isolate the unknown variables. However, every term in each equation must be examined for dimensional homogeneity.
4. *Material Law Formulas*. The material law formulas are written for each part of a structure based on the Model in Step 1. All equations are formulated symbolically and there is no algebraic manipulation. Every term in each equation must be examined for dimensional homogeneity.
5. *Compatibility and Boundary Conditions*. One or more compatibility equations are written in symbolic form to relate the displacements. A compatibility diagram is used when appropriate to assist in developing the compatibility equations. All equations are formulated symbolically and there is no algebraic manipulation. Every term in each equation must be examined for dimensional homogeneity. Although compatibility equations are commonly written for indeterminate problems, the authors emphasize their use for determinate problems just as is done in the textbooks by Craig<sup>9</sup>, Crandall<sup>10</sup> et al., Shames<sup>37</sup>, and Shames & Pitarresi<sup>38</sup>.
6. *Complementary and Supporting Formulas*. Steps 1 through 5 are sufficient to solve for the (primary) variables for force and displacement in a structures problem. Step 6 includes complementary formulas for other (secondary) variables such as stress and strain, variables which may govern the maximum allowable in service values of force and displacement, but which do not affect the governing equilibrium or deformation equations. Supporting formulas are those which might be required to supply variable values in the Material Law equations and complementary formulas; formulas such as area, moment of inertia, centroid location of a cross-section, volume, etc. The complementary and supporting formulas are written symbolically and are necessary to develop a complete analysis.

7. *Solve*. The independent equations developed in Steps 3 through 6 solve the problem. The students compare the number of independent equations and the number of unknowns. The authors emphasize that the student should not proceed until the number of unknowns equals the number of independent equations.

The solution may be obtained by hand, and this generally requires algebraic manipulation. Alternatively, the solution of any number of equations, linear or non-linear, can be obtained with a modern engineering tool. With intelligent application of verification (Step 8), the computer program is a much more reliable calculation device than a calculator. (ABET<sup>52</sup> criterion 3(k) states that engineering programs must demonstrate that their students have the “ability to use the techniques, skills, and modern engineering tools necessary for engineering practice”.) The students are allowed to select the modern engineering tool of their choice, and this might include Mathcad<sup>53</sup>, Matlab<sup>54</sup> and TKSolver<sup>55</sup>. The authors have not seen this solution procedure in any mechanics of materials textbook.

8. *Verify*. One of our educational goals is to convince students of the wisdom to question and test solutions to verify their ‘answers’. The verify Step 8 is carried out after solution Step 7 is performed once. The power of our proposed use of the modern engineering tool rests in the ability to quickly and easily run many cases to verify the problem solution. How does one test the problem solution? Some suggested questions that students may apply for the purpose of verification of their ‘answers’ are as follows: a. A hand calculation?; b. Comparison with a known problem solution?; c. Examination of limiting cases with known solutions?; d. Examination of the obvious solution?; e. Your best judgment?; f. Comparison with experimentation (not considered)?. As indicated, attempts at solution verification may take many forms, and, although in some cases it may not yield absolute proof, it does improve the level of confidence. This step is considered only in the mechanics of materials textbook by Craig<sup>9</sup>.

Problems in statics require only Steps 1, 2, 3, 6 and 7. These five steps have not been employed in the treatment of statics problems in any statics or mechanics of materials textbook. Furthermore, Steps 1 through 8 have not been suggested in any mechanics of materials textbook.

### **Example 1: Statically Determinate Problem**

A uniform simply supported circular stepped shaft of different diameters carries a uniformly distributed load over a portion of the beam span as shown in Figure 6. Using the Material Law Formulas in Figure 5, derive symbolic relationships for the internal shear force and bending couple and for the slope and displacement of the neutral surface for the full length of the beam. Solve for and plot the diagrams for the shear force, bending couple, slope and displacement using the following load and beam specifications.

$$w = 16 \frac{lb}{in}, \quad L_1 = 50 \text{ in}, \quad L_2 = 150 \text{ in}$$
$$d_1 = 4.0 \text{ in}, \quad d_2 = 3.75 \text{ in}, \quad E = 29(10^6) \text{ psi}$$



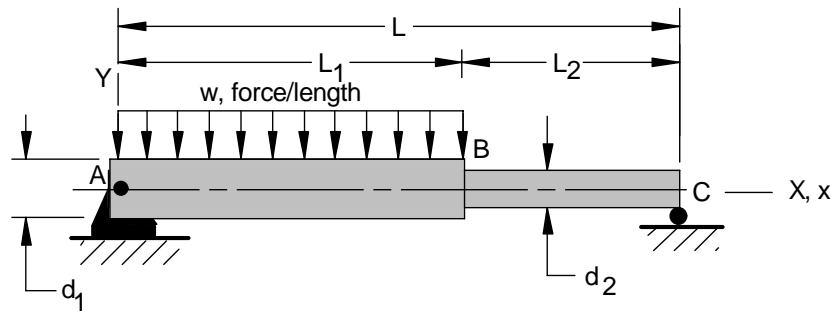

Figure 6. Simply supported stepped shaft with partial distributed load.

**SOLUTION:**

The analysis process is based on the eight steps discussed in the previous section.

1. **Model.** The simply supported beam carries a distributed transverse load over a portion of the span. In order to use the Material Law in Figure 5, the beam must be divided into segments, each having uniform cross-section inertia and material properties and loading consisting of end shear forces, end bending couples and a uniformly distributed load. This segment division is shown in Figure 7. With the exception of FBD I, all diagrams satisfy these segment requirements.
2. **Free-Body Diagrams.** The free-body diagrams are shown in Figure 7. The partial segment FBDs II and III are drawn because we wish to derive the solution for shear force, bending couple and neutral surface slope and displacement for the entire length of the beam. These diagrams will provide expressions at the arbitrary  $x$  locations. Free-body diagrams IV and V are necessary to define the solution at the specific boundary supports and segment junctures.

Note that the applied beam load,  $w$ , is carried on segment (1), the distributed load on segment (2) is zero. Also note, the internal shear force  $F_{s_B}^{(1)}$  and bending couple,  $M_B^{(1)}$ , although labeled to be considered in the segment (1) side of the slice at location  $B$ , are single valued at  $B$ , there is no applied force or couple at  $B$  to produce a discontinuity in either the internal force or couple.

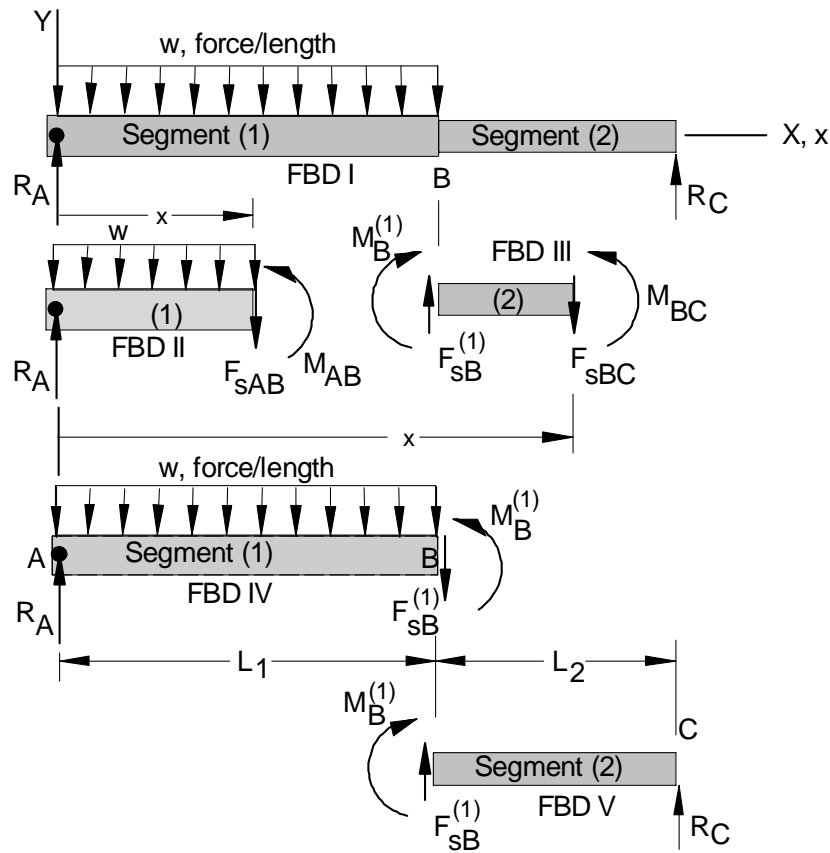

Figure 7. Free-body diagrams of the simply supported stepped shaft.

3. **Equilibrium Equations.** The FBDs in Figure 7 involves 8 unknowns. There are 5 free-body diagrams shown, but only 4 are independent. Free-body diagrams I, IV and V are dependent, because FBD IV and V sum to FBD I.

This problem is statically determinate. We will solve for the reaction forces first. From equilibrium of FBD I, the entire beam:

$$\text{FBD I: } \sum F_Y : R_A + R_C = wL_1 \quad (1.1)$$

$$\sum M_A : R_C L = \frac{wL_1^2}{2} \quad (1.2)$$

Free-body diagram II will provide relationships for the internal shear force,  $F_{s_{AB}}$ , and bending couple,  $M_{AB}$ , for values of  $x$  between  $x_A = 0$  and  $x_B = L_1$ .

$$\text{FBD II: } \sum F_Y : F_{s_{AB}} + wx = R_A \quad (1.3)$$

$$\sum M_{cut} : M_{AB} + \frac{wx^2}{2} = R_A x \quad (1.4)$$

Free-body diagram III will provide relationships for the internal shear force,  $F_{s_{BC}}$ , and bending couple,  $M_{BC}$ , for values of  $x$  between  $x_B = L_1$  and  $x_C = L$ .

$$\text{FBD III: } \sum F_Y : F_{s_{BC}} = F_{s_B}^{(1)} \quad (1.5)$$

$$\sum M_{cut} : M_{BC} = F_{s_B}^{(1)}(x - L_1) + M_B^{(1)} \quad (1.6)$$

Free-body diagram IV will provide relationships for the internal shear force,  $F_{s_B}^{(1)}$ , and bending couple,  $M_B^{(1)}$ , at  $x = x_B = L_1$ .

$$\text{FBD IV: } \sum F_Y : F_{s_B}^{(1)} + wL_1 = R_A \quad (1.7)$$

$$\sum M_{cut} : M_B^{(1)} + \frac{wL_1^2}{2} = R_A L_1 \quad (1.8)$$

There are 8 unknowns

$$R_A, R_C, F_{s_{AB}}, M_{AB}, F_{s_{BC}}, F_{s_B}^{(1)}, M_{BC} \text{ and } M_B^{(1)}$$

that may be solved with the 8 equilibrium equations, Equations 1.1 through 1.8.

4. **Material Law Formulas.** The Material Law Formulas in Figure 5 will be applied to each of the partial and full segments.

$$\theta_b = \theta_a + \frac{M_b L}{EI_z} - \frac{F_{s_b} L^2}{2EI_z} - \frac{wL^3}{6EI_z}, \quad \text{from Figure 5}$$

$$v_b = v_a + \theta_a L + \frac{M_b L^2}{2EI_z} - \frac{F_{s_b} L^3}{3EI_z} - \frac{wL^4}{8EI_z}, \quad \text{from Figure 5}$$

Pay careful attention to notation as you substitute the problem variables for the general symbols in the Material Law Formulas. Note that segments (1) and (2) have different values of moment of inertia. The Young's modulus for segment (1) is different from that of segment (2) in writing the Material Law Formulas for each segment. For this problem, however, data input would have  $E_1 = E_2$ .

(a) Partial Segment (1), FBD II,  $0 \leq x \leq L_1$ :

$$\theta_{AB} = \theta_A + \frac{M_{AB} x}{E_1 I_{z_1}} - \frac{F_{s_{AB}} x^2}{2E_1 I_{z_1}} - \frac{wx^2}{6E_1 I_{z_1}} \quad (1.9)$$

$$v_{AB} = v_A + \theta_A x + \frac{M_{AB} x^2}{2E_1 I_{z_1}} - \frac{F_{s_{AB}} x^3}{3E_1 I_{z_1}} - \frac{wx^4}{8E_1 I_{z_1}} \quad (1.10)$$

(b) *Partial Segment (2), FBD III,  $L_1 \leq x \leq L$  :*

$$\theta_{BC} = \theta_B + \frac{M_{BC}(x-L_1)}{E_2 I_{z_2}} - \frac{F_{s_{BC}}(x-L_1)^2}{2E_2 I_{z_2}} \quad (1.11)$$

$$v_{BC} = v_B + \theta_B(x-L_1) + \frac{M_{BC}(x-L_1)^2}{2E_2 I_{z_2}} - \frac{F_{s_{BC}}(x-L_1)^3}{3E_2 I_{z_2}} \quad (1.12)$$

(c) *Full Segment (1), FBD IV:*

$$\theta_B = \theta_A + \frac{M_B^{(1)} L_1}{E_1 I_{z_1}} - \frac{F_{s_B}^{(1)} L_1^2}{2E_1 I_{z_1}} - \frac{w L_1^3}{6E_1 I_{z_1}} \quad (1.13)$$

$$v_B = v_A + \theta_A x_B + \frac{M_B^{(1)} L_1^2}{2E_1 I_{z_1}} - \frac{F_{s_B}^{(1)} L_1^3}{3E_1 I_{z_1}} - \frac{w L_1^4}{8E_1 I_{z_1}} \quad (1.14)$$

(d) *Full Segment (2), FBD V: Note that the right end couple and the distributed load are zero, and the support reaction  $R_C$  results in a negative internal shear force at end C:*

$$M_b \Rightarrow M_c = 0$$

$$F_{s_b} \Rightarrow F_{s_c} = -R_C$$

$$\theta_C = \theta_B - \frac{(-R_C)L_2^2}{2E_2 I_{z_2}} \quad (1.15)$$

$$v_C = v_B + \theta_B L_2 - \frac{(-R_C)L_2^3}{3E_2 I_{z_2}} \quad (1.16)$$

5. **Compatibility and Boundary Conditions.** *The beam has been separated into two segments for analysis, and the segments must be rejoined. The fact that the right end of segment (1) and the left end of segment (2) are attached is assured by providing the same slope and displacement symbol designation for each segment at the juncture.*

*The boundary conditions for this beam are established by the rigid pin and roller supports at A and C.*

$$v_A = 0$$

$$v_C = 0$$

6. **Complementary and Supporting Formulas.** *In general, formulas would be applied here to calculate stress and the area moment of inertia. In this example, we require the area moment of inertia for segments (1) and (2).*

$$I_{z_1} = \frac{\pi d_1^4}{64} \quad (i)$$

$$I_{z_2} = \frac{\pi d_2^4}{64} \quad (ii)$$

7. **Solve.** *Some things should be apparent in this solution formulation; integration is not required, it has already been done, and there are no constants of integration to be determined.*

*Considering the boundary values as known, there are an additional 8 unknowns generated in writing the Material Law equations*

$$\theta_{AB}, \theta_A, v_{AB}, \theta_{BC}, \theta_B, v_{BC}, v_B \text{ and } \theta_C$$

*Thus, in summary, we have a total of the following 16 unknowns*

$$R_A, R_C, F_{s_{AB}}, M_{AB}, F_{s_{BC}}, F_{s_B}^{(1)}, M_{BC} \text{ and } M_B^{(1)} \\ \theta_{AB}, \theta_A, v_{AB}, \theta_{BC}, \theta_B, v_{BC}, v_B \text{ and } \theta_C$$

*which can be solved with the 8 equilibrium equations, Equations 1.1 through 1.8, and the additional 8 Material Law Formulas, Equations 1.9 through 1.16. The equations will be solved with an equation solver, e.g., MathCad<sup>53</sup>, MatLab<sup>54</sup> or TKSolver<sup>55</sup>.*

*The following results are presented for forces and displacements at locations A, B and C.*

$$\begin{aligned} R_A &= 700 \text{ lb}, & R_C &= 100 \text{ lb} \\ F_{s_B}^{(1)} &= -100 \text{ lb}, & M_B^{(1)} &= 15000 \text{ lb} \cdot \text{in} \\ \theta_A &= -3.26 (10^{-3}) \text{ rad}, & \theta_B &= -1.77 (10^{-3}) \text{ rad}, & \theta_C &= 2.23 (10^{-3}) \text{ rad} \\ v_B &= -1.34 (10^{-1}) \text{ in} \end{aligned}$$

*The diagrams in Figure 8 are plots of the dependent variables over the full length of the beam.*

8. **Verify.** *Test the solution.*
- *Setting the distributed load  $w = 0$  will yield the obvious solution of a zero response.*
  - *Changing the sign of the distributed load will result in reactions of the same magnitude but opposite direction.*
  - *Run a solution with a distributed load, constant material and constant moment of inertia over the full span and check for symmetry and compare the value of maximum displacement and end rotations with other sources found in a handbook ( $v(L/2) = -5wL^4/384EI_z$  and  $\theta(0) = -\theta(L) = -wL^3/24EI_z$ ). The reaction forces will also be  $R_A = R_B = wL/2$ .*
  - *The best approach to the solution of a problem like this is to plot all of the dependent variables as has been done in Figure 8. Gaps in the diagrams, discontinuities which should not exist, failure to match boundary values, etc., can flash a warning that something is not right.*
  - *Calculate and check intermediate values by hand.*

Two other checks the authors have found to be helpful for all problems are:

- Double check the input.
- Go back and check the solution after a few days.

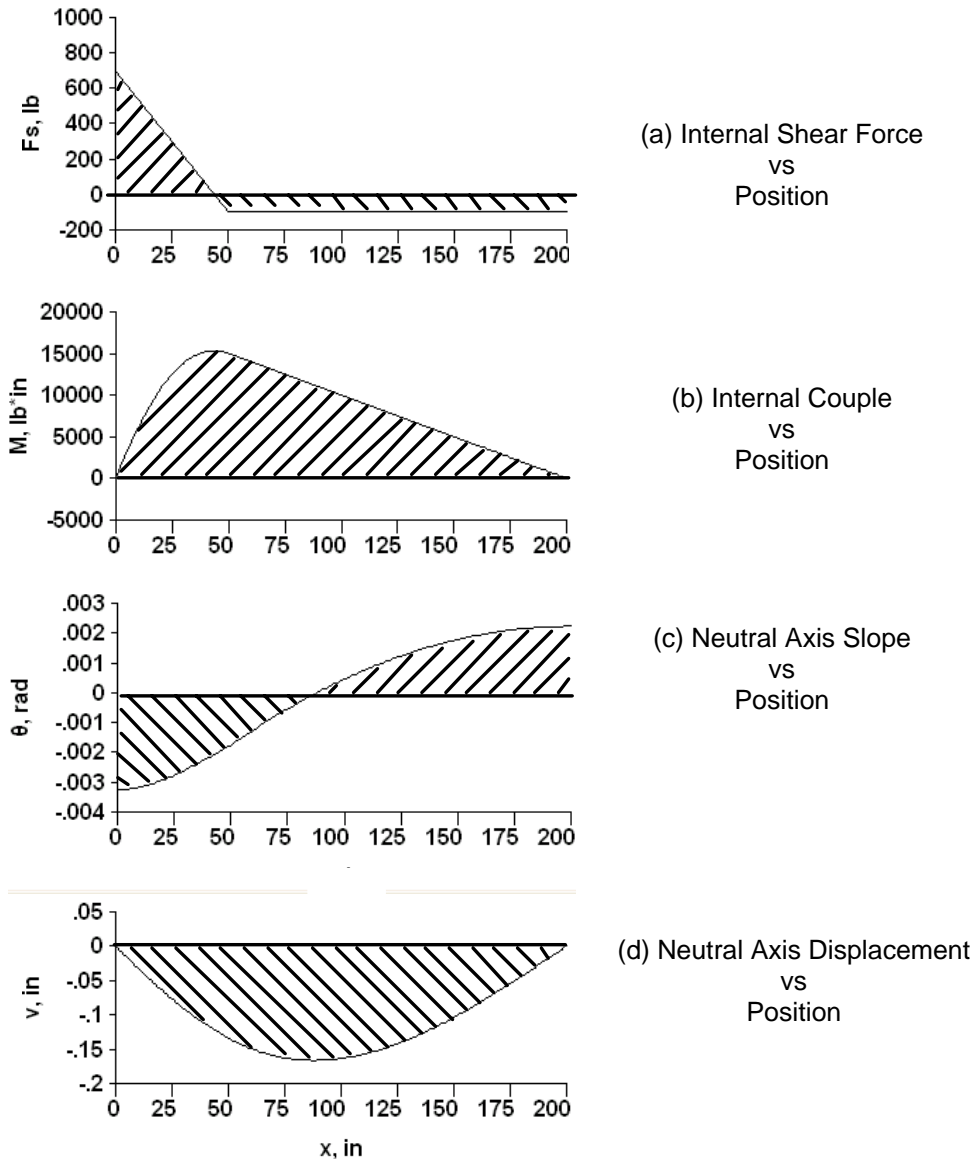

Figure 8. Shear, bending couple, slope and displacement diagrams for simply supported beam.

### Example 2: Statically Indeterminate Problem

Consider the beam shown in Figure 9. It is solidly built into the wall at the left end, and supported on the roller at the right end. A couple,  $C_B$ , of known magnitude is applied to the right end. Solve, using the Material Law Formulas in Figure 5, for the symbolic relationships for the reaction forces exerted by the wall, end A, and the roller at end B.

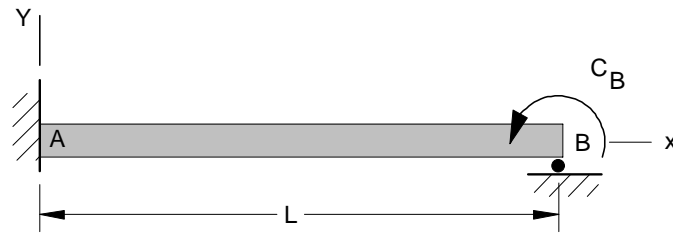

Figure 9. Propped cantilever beam with concentrated couple.

**SOLUTION:**

1. **Model.** The full beam satisfies the requirements of the Material Law beam model; one length with continuous material, geometry, distributed load (zero) and end loads. Therefore, the full beam may be used, there is no need to establish smaller segments.
2. **Free-Body Diagrams.** The free-body diagram of the full beam is shown in Figure 10.

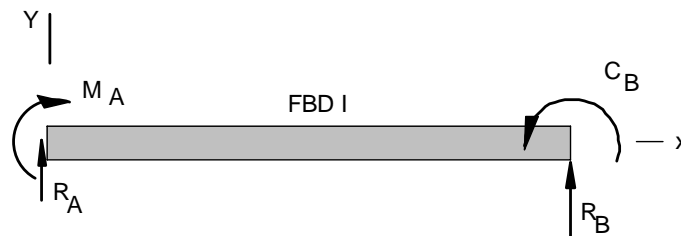

Figure 10. Free-body diagram of the propped cantilever beam.

3. **Equilibrium Equations.** The force and moment equilibrium equations for the beam reaction forces in Figure 10 are as follows:

$$R_A + R_B = 0 \quad (2.1)$$

$$M_A + R_A L = C_B \quad (2.2)$$

Given the couple  $C_B$ , there are three unknowns,  $R_A$ ,  $R_B$  and  $M_A$ . Since there are only two independent equilibrium equations, these equations alone are insufficient to solve for the unknowns; the problem is statically indeterminate. Therefore, the deformation properties of the beam must be introduced.

4. **Material Law Formulas.** The Material Law Formulas will be applied to the full beam:

$$\theta_b = \theta_a + \frac{M_b L}{EI_z} - \frac{F_{s_b} L^2}{2EI_z} - \frac{wL^3}{6EI_z}, \quad \text{from Figure 5}$$

$$v_b = v_a + \theta_a L + \frac{M_b L^2}{2EI_z} - \frac{F_{s_b} L^3}{3EI_z} - \frac{wL^4}{8EI_z}, \quad \text{from Figure 5}$$

Relating the problem variables and values to the symbols in the formulas, we have:

$$\begin{aligned} \theta_b &\Rightarrow \theta_B, & \theta_a &\Rightarrow \theta_A, & v_b &\Rightarrow v_B \\ M_b &\Rightarrow M_B = C_B, & F_{s_b} &\Rightarrow F_{s_B} = -R_B, & w &= 0 \end{aligned}$$

Substituting into the Material Law Formulas yields

$$\theta_B = \theta_A + \frac{C_B L}{EI_z} - \frac{(-R_B)L^2}{2EI_z} \quad (2.3)$$

$$v_B = v_A + \theta_A L + \frac{C_B L^2}{2EI_z} - \frac{(-R_B)L^3}{3EI_z} \quad (2.4)$$

5. **Boundary Conditions.** The boundary conditions for this beam are:

$$\begin{aligned} v_A &= 0 \\ \theta_A &= 0 \\ v_B &= 0 \end{aligned}$$

6. **Complementary and Supporting Formulas.** In general, formulas would be applied here to calculate the area moment of inertia.

7. **Solve.** There are four unknowns as follows:

$$R_A, R_B, M_A \text{ and } \theta_A$$

which can be solved using Equations 2.1 through 2.4. As an alternative to using an equation solver, the problem will be solved by hand to obtain symbolic formulas for the solution. Substituting the boundary conditions into Equations 2.3 and 2.4 yields the following:

$$\theta_B = 0 + \frac{C_B L}{EI_z} - \frac{(-R_B)L^2}{2EI_z} \quad (i)$$

$$0 = 0 + 0 + \frac{C_B L^2}{2EI_z} - \frac{(-R_B)L^3}{3EI_z} \quad (ii)$$

Solving Equation ii for the reaction force  $R_B$  yields:

$$R_B = -\frac{3 C_B}{2 L}$$



Substitution into Equations 2.1 and 2.2 yields the force and couple at end A.

$$R_A = \frac{3 C_B}{2 L}$$
$$M_A = -\frac{C_B}{2}$$

The rotation at end B was not requested, but from Equation i yields:

$$\theta_B = 0 + \frac{C_B L}{EI_z} - \frac{[-(-3C_B / 2L)]L^2}{2EI_z}$$
$$\theta_B = \frac{C_B L}{4EI_z}$$

8. **Verify.** Verify the solution with the following tests:

- Setting the couple  $C_B = 0$  will yield a zero response.
- Changing the sign of couple  $C_B$  will result in reactions of the same magnitude but opposite direction.
- The direction of applied couple  $C_B$  is consistent with the directions of rotation  $\theta_B$  and neutral axis displacement.
- Place the unknown reactions on the free-body diagram in Figure 10 and check equilibrium.
- Compare the solution with a handbook.
- Check solution though a hand calculation if an engineering tool was used.

### Beam Deflection Methods Commonly Found in Mechanics of Materials Textbooks

A review of mechanics of materials textbooks<sup>1-50</sup> was carried out by the authors to determine the most commonly used methods to solve beam deflection problems. The review revealed that the five most popular methods<sup>1-50</sup> include double integration, superposition, singularity (discontinuity or step) functions, moment area and Castigliano's. Other less popular methods include fourth-order<sup>5,6,9,15,16,26-29,48</sup> and the unit (dummy) load<sup>9,15,16,22,27-30,33,41,42,47</sup> methods. A very limited number of authors use conjugate beam<sup>30,41,42,44</sup>, finite-difference method<sup>24,47</sup>, finite element<sup>20,38</sup>, moment distribution<sup>24,30,41,42</sup> and the three-moment equation<sup>12,25,30,34,41-46</sup>. The authors are not aware of any mechanics of materials textbook that has used the Method of Segments to solve beam deflection problems.

The authors want to point out that such methods as double integration, singularity and fourth-order require identification of the regions of continuous geometry, material and loading. However, the direct integration methods yield constants of integration which must be defined in terms of boundary conditions and continuity relationships. The proposed Method of Segments involves no integration, no solution of integration constants and requires no separate equations of continuity.

Why introduce another beam deflection method in the introductory mechanics of materials course? The primary answers are as follows:

- The proposed Method of Segments is an approach which is consistent with the commonly adopted solution methods of direct integration applied to the axial bar and torsional shaft problems.
- Application of the derived Material Law simplifies the algebraic development of the equations, and reduces the potential for error.

With an understanding of the theory of the Material Law Formula development and application of Method of Segments, only one method is needed to solve determinate and indeterminate beam deflection problems.

### **Advantages and Disadvantages of the Method of Segments**

The four advantages of the proposed Method of Segments include the following:

- *Consistent Solution Approach.* The Method of Segments for beams is consistent with the method commonly found in mechanics of materials textbooks to solve axially loaded bars and torsionally loaded shafts. The Material Law of each problem type is derived from basic principles using single integration for axially and torsionally loaded bars and double integration for transversely loaded bars. No additional solution approach, such as moment area, singularity functions, superposition and Castigliano's theorem, is required to solve beam deflection problems.
- *Non-uniform Beams.* The Method of Segments can easily be applied to beams with uniform step changes in geometry and material. A literature review by the authors determined that the most commonly used methods in mechanics of materials textbooks<sup>1-50</sup> to analyze non-uniform beams include double integration<sup>7,20,26-29,31,33,36-39,43,44,48</sup> and moment area<sup>1-3,5,6,14-16,22,24,25,27-31,33,34,42-47</sup>. All textbooks do emphasize non-uniform bar and shaft problems. However, not as much emphasis is placed on non-uniform beams.
- *No Integration Required.* Application of the Material Law Formulas can be applied to any beam problem without the need for integration since the Material Law Formulas were developed using double integration. This eliminates the need to solve for integration constants and, overall, reduces the potential for algebraic error.
- *No Continuity Equations Required.* Since a beam must be separated into segments for analysis, the segments must be rejoined. The fact that the right end of one segment and the left end of the adjacent segment are attached is assured by providing the same symbol designation for each segment at the juncture. Therefore, this satisfies point compatibility and continuity equations are not required.

The two disadvantages of the proposed Method of Segments include the following:

- *Complex Equations.* Compared to the axially loaded bar in Figure 1 and torsionally loaded bars in Figure 2, the basic Material Law for a transversely loaded bar (beam) in Figure 5 is more difficult to remember since there are two formulas and more terms in each formula.

However, if a person is solving beams problems frequently, remembering the Material Law formulas is not an issue.

- *Simple Beams.* The method discussed in this paper is limited to a uniform beam supporting a uniformly distributed load with end shear forces and bending couples. However, these cases are commonly found in practice for beams just like axially loaded and torsionally loaded bars. Moreover, a Material Law could be developed for other beam loadings and geometries.

## Conclusion

A new approach has been developed to solve beam deflections problems that are consistent with solving axially loaded bars and torsionally loaded shafts. Two examples were presented that demonstrated the method applied to statically determinate and indeterminate problems. With an understanding of the theory of the Material Law development and application of Method of Segments, this method alone could suffice in an introductory mechanics of materials course to solve determinate and indeterminate beam deflection problems.

## Bibliography

1. Bauld, N.R., *Mechanics of Materials*, Second Edition, PWS Engineering, Boston, MA, 1986.
2. Beer, F.P., Johnston, E.R. and DeWolf, J.T., *Mechanics of Materials*, Third Edition, McGraw-Hill, New York, NY, 2001.
3. Beer, F.P. and Johnston, E.R., *Mechanics of Materials*, Second Edition, McGraw-Hill, New York, NY, 1992.
4. Bedford, A. and Liechti, K.M., *Mechanics of Materials*, Prentice Hall, Upper Saddle River, NJ, 2000.
5. Bickford, W.B., *Mechanics of Solids: Concepts and Applications*, Irwin, Boston, MA, 1993.
6. Bowes, W.H., Russell, L.T. and Suter, G.T., *Mechanics of Engineering Materials*, John Wiley & Sons, New York, NY, 1984.
7. Buchanan, G.R., *Mechanics of Materials*, International Thomas Publishing, Belmont, CA, 1997.
8. Byars, E.F. and Snyder, R.D., *Engineering Mechanics of Deformable Bodies*, International Textbook Company, Scranton, PA, 1969.
9. Craig, R.R., *Mechanics of Materials*, Second Edition, John Wiley & Sons, New York, NY, 2000.
10. Crandall, S. H., Dahl, N. C. and Lardner, T. L., *An Introduction to the Mechanics of Solids*, Second Edition, McGraw-Hill Book Company, New York, NY, 1978.
11. Eckardt, O.W., *Strength of Materials*, Holt, Rinehart and Winston, Inc., New York, NY, 1969.
12. Fitzgerald, R.W., *Mechanics of Materials*, Second Edition, Addison-Welsey Publishing Company, Reading MA, 1982.
13. Fletcher, D.Q., *Mechanics of Materials*, International Thomson Publishing, Belmont, CA, 1985.
14. Gere, J.M., *Mechanics of Materials*, Sixth Edition, Brooks/Cole-Thomson Learning, Belmont, CA, 2004.
15. Gere, J.M. and Timoshenko, S.P., *Mechanics of Materials*, Third Edition, PWS-KENT Publishing Company, Boston, MA, 1990.
16. Gere, J.M. and Timoshenko, S.P., *Mechanics of Materials*, Second Edition, Brooks/Cole Engineering Division, Monterey, CA, 1984.
17. Hibbeler, R.C., *Mechanics of Materials*, Fifth Edition, Prentice Hall, Upper Saddle River, NJ, 2003.
18. Hibbeler, R.C., *Mechanics of Materials*, Fourth Edition, Prentice Hall, Upper Saddle River, NJ, 2000.
19. Higdon, A., Ohlsen, E.H., Stiles, W.B. and Weese, J.A., *Mechanics of Materials*, Second Edition, John Wiley & Sons, New York, NY, 1966.
20. Lardner, T.J. and Archer, R.R., *Mechanics of Solids: An Introduction*, McGraw-Hill, New York, NY, 1994.
21. Levinson, I.J., *Mechanics of Materials*, 2<sup>nd</sup> Edition, Prentice-Hall, Inc., Englewood Cliffs, NJ, 1963.
22. Logan, D.L., *Mechanics of Materials*, HarperCollins Publishers, New York, NY, 1991.

23. McKinley, J.W., *Fundamentals of Stress Analysis*, Matrix Publishers, Inc., Portland, OR, 1979.
24. Olsen, G.A., *Elements of Mechanics of Materials*, Forth Edition, Prentice-Hall, Englewood Cliffs, NJ, 1982.
25. Panlilio, F., *Elementary Theory of Structural Strength*, John Wiley & Sons, New York, NY, 1963.
26. Pilkey, W.D. and Pilkey, O.H., *Mechanics of Solids*, Quantum Publishers, Inc., New York, NY, 1974.
27. Popov, E.P., *Engineering Mechanics of Solids*, Second Edition, Prentice Hall, Upper Saddle River, NJ, 1999.
28. Popov, E.P., *Engineering Mechanics of Solids*, Prentice Hall, Upper Saddle River, NJ, 1990.
29. Popov, E.P., *Mechanics of Materials*, Second Edition, Prentice Hall, Upper Saddle River, NJ, 1976.
30. Pytel, A.W. and Singer, F.L., *Strength of Materials*, Forth Edition, Harper & Row, Publishers, New York, NY, 1987.
31. Pytel, A. and Kiusalaas, J., *Mechanics of Materials*, Brooks/Cole-Thomson Learning, Belmont, CA, 2003.
32. Riley, W.F., Sturges, L.D. and Morris, D.H., *Mechanics of Materials*, Fifth Edition, John Wiley & Sons, New York, NY, 1999.
33. Riley, W.F. and Zachary, L., *Introduction to Mechanics of Materials*, John Wiley & Sons, New York, NY, 1989.
34. Robinson, J.L., *Mechanics of Materials*, John Wiley & Sons, Inc., New York, NY, 1969.
35. Roylance, D., *Mechanics of Materials*, John Wiley & Sons, New York, NY, 1996.
36. Shames, I.H., *Mechanics of Deformable Bodies*, Prentice-Hall, Inc., Englewood Cliffs, NJ, 1964.
37. Shames, I.H., *Introduction to Solid Mechanics*, Prentice Hall, Upper Saddle River, NJ, 1975.
38. Shames, I.H., *Introduction to Solid Mechanics*, Second Edition, Prentice-Hall, Inc., Englewood Cliffs, NJ, 1989.
39. Shames, I.H. and Pitarresi, J.M., *Introduction to Solid Mechanics*, Third Edition, Prentice Hall, Upper Saddle River, NJ, 2000.
40. Shanley, F.R., *Mechanics of Materials*, McGraw-Hill Book Company, New York, NY, 1967.
41. Singer, F.L., *Strength of Materials*, Second Edition, Harper & Row Publishers, New York, NY, 1962.
42. Singer, F.L. and Pytel, A.W., *Strength of Materials*, Third Edition, Harper & Row, Publishers, New York, NY, 1980.
43. Timoshenko, S., *Strength of Materials: Part I Elementary Theory and Problems*, D. Van Nostrand Company, Inc., New York, NY, 1930.
44. Timoshenko, S. and MacCullough, G.H., *Elements of Strength of Materials*, D. Van Nostrand Company, Inc., New York, NY, 1935.
45. Timoshenko, S. and Young, D.H., *Elements of Strength of Materials*, Forth Edition, D. Van Nostrand Company, Inc., Princeton, NJ, 1962.
46. Timoshenko, S. and Young, D.H., *Elements of Strength of Materials*, Fifth Edition, D. Van Nostrand Company, Inc., New York, 1968.
47. Ugural, A.C., *Mechanics of Materials*, McGraw-Hill, New York, NY, 1991.
48. Vable, M., *Mechanics of Materials*, Oxford University Press, New York, NY, 2002.
49. Wempner, G., *Mechanics of Solids*, PWS Publishing Company, Boston, MA, 1995.
50. Yeigh, B.W., *Mechanics of Materials Companion: Case Studies, Design, and Retrofit*, John Wiley & Sons, New York, NY, 2002.
51. Rencis, J.J. and Grandin, H.T., "Mechanics of Materials: an Introductory Course with Integration of Theory, Analysis, Verification and Design," *2005 American Society for Engineering Education Annual Conference & Exposition*, Portland, OR, June 12-15, 2005.
52. *Engineering and Engineering Technology Accreditation*, Accreditation Board for Engineering and Technology, Inc., 111 Market Place, Suite 1050, Baltimore, MD, 21202, <http://www.abet.org/criteria.html>.
53. *Mathcad*, Mathsoft Engineering & Education, Inc., Cambridge, MA, <http://www.mathsoft.com/>.
54. *MATLAB*, TheMathWorks, Inc., Natick, MA, <http://www.mathworks.com/>.
55. *TK Solver*, Universal Technical Systems, Rockford, IL, <http://www.uts.com/>.

## **Biographical Information**

### **JOSEPH J. RENCIS**

Joseph J. Rencis is Professor and Head of the Department of Mechanical Engineering at the University of Arkansas, Fayetteville. He also holds the inaugural 21<sup>st</sup> Century Leadership Chair in Mechanical Engineering. From 1985 to 2004 he was professor in the Mechanical Engineering Department at Worcester Polytechnic Institute. His research focuses on the development of boundary and finite element methods for analyzing solid, heat transfer, and fluid mechanics problems. He currently serves on the editorial board of Engineering Analysis with Boundary Elements and is associate editor of the international Series on Advances in Boundary Elements. Currently he serves as the Chair of the ASME Mechanical Engineering Department Heads Committee, Chair of the ASEE Mechanical Engineering Division, and an ABET program evaluator. He received the 2002 ASEE New England Section Teacher of Year Award, 2004 ASEE New England Section Outstanding Leader Award, and 2006 ASEE Mechanics Division James L. Meriam Service Award. He is a fellow of ASME and ASEE. He received a B.S. from Milwaukee School of Engineering in 1980, a M.S. from Northwestern University in 1982, and a Ph.D. from Case Western Reserve University in 1985. E-mail: [jjrencis@uark.edu](mailto:jjrencis@uark.edu)

### **HARTLEY T. GRANDIN, JR.**

Hartley T. Grandin, Jr. is a Professor Emeritus of Engineering Mechanics and Design in the Mechanical Engineering Department at Worcester Polytechnic Institute. He has authored the textbook Fundamentals of the Finite Element Method that was published by Macmillan in 1986. Since his retirement from WPI in 1996, he teaches a mechanics of materials course each year and is currently writing the fifth draft of an introductory textbook with the co-author. In 1983 he received the WPI Board of Trustees' Award for Outstanding Teaching. He received his B.S. in 1955 and an M.S. in 1960 in Mechanical Engineering from Worcester Polytechnic Institute and a Ph.D. in Engineering Mechanics from the Department of Metallurgy, Mechanics and Materials Science at Michigan State University in 1972. E-mail: [hgrandin@rcn.com](mailto:hgrandin@rcn.com) and [hgrandin@wpi.edu](mailto:hgrandin@wpi.edu)