

## **Spatial Reasoning Difference between Civil and Mechanical Engineering Students in Learning Mechanics of Materials Course: A Case of Cross-sectional Inference**

### **Dr. Oai Ha, Western Carolina University**

Dr. Oai Ha is currently an Assistant Professor in mechanical engineering in the School of Engineering and Technology at Western Carolina University. He was a Postdoctoral Scholar at the School of Civil and Construction Engineering at the Oregon State University, working in the Engineering Cognition Lab on several engineering education research projects. He holds a Ph.D. in Engineering Education from Utah State University, an M.S. in mechanical engineering from California Polytechnic State University in San Luis Obispo, and a B.S. in mechanical engineering from the University of Technology in Ho Chi Minh City, Vietnam. His research interests include building energy efficiency, computer simulations, spatial visualization skills, educational data mining, learning analytics, and cognitive processes in engineering design and problem-solving.

### **Dr. Shane A. Brown P.E., Oregon State University**

Shane Brown is an associate professor and Associate School Head in the School of Civil and Environmental Engineering at Oregon State University. His research interests include conceptual change and situated cognition. He received the NSF CAREER award in 2010 and is working on a study to characterize practicing engineers' understandings of core engineering concepts. He is a Senior Associate Editor for the Journal of Engineering Education.

## Spatial reasoning difference between civil and mechanical engineering students in learning Mechanics of Materials course: a case of cross-sectional inference

### **Abstract.**

Despite the fact that Mechanics of Materials (MM) course is laden with spatial concepts, the role of spatial skills in the learning of MM course has not been investigated adequately. This study investigated the relationship between students' performances of the MM course measured by the Mechanics of Material Concept Inventory Test and their cross sectioning ability measured by the Santa Barbara Solids Test. Participants are the freshman and sophomore students mostly majoring in civil and mechanical engineering (CE and ME) at six colleges across the United States. While CE and ME students performed almost equally on the two tests, the correlations between MMCI and SBST and its subtest scores on vertical cuts of joined objects and oblique cuts of simple objects were higher for CE than for ME students. As the results, the percentages of variance explained by cross-sectioning abilities in the performance of Mechanics of Materials course were higher for CE than for ME students. It was interpreted that a good cross-sectional reasoning skill is more important in learning the MM course for CE students than it is for ME students. Instructors and future research may use SBST, its subtests, and students' engineering fields to predict students' learning outcomes of the MM course.

*Keywords:* Mechanics of materials, spatial visualization skills, cross-sectioning skill, engineering education.

### **Introduction**

Mechanics of materials is a subject in engineering mechanics and one of the required courses in many engineering disciplines such as civil engineering (CE) and mechanical engineering (ME). A good mathematics and physics background is often required to help students achieve the learning outcomes set for the course. Students' performance of the course also depends on their spatial abilities to render abstract concepts in graphical representations and extract correct spatial information from the structures' drawings. Spatial ability is defined as the processes of constructing, maintaining, and manipulating three-dimensional (3D) objects in one's mind [1, 2, 3] and considered to have multiple subfactors [4, 5] such as spatial visualization, spatial orientation, and speed rotation [6]. Research studies that discussed the roles of spatial ability in engineering education have primarily focused on the spatial visualization, which is the main factor of spatial ability [7]. Some widely used spatial visualization tests in engineering education [8, 9, 10] include the Purdue Spatial Visualization Test: Rotations (PSVT: R) [11], the Vandenberg Mental Rotation Test [12], the paper folding tests [13], and the mental cutting test [14].

In learning the MM course, students frequently use their spatial visualization skills to understand mechanics structures presented in 2D or 3D pictures and solve problems in this domain such as determining various types of loadings acting on a structure or drawing 2D/3D stress analysis diagrams on a cross section of a structure. For examples, students use their cross-sectioning skills to infer the right cross section of the structures to evaluate their stiffness (Fig. 1) and determine various types of loadings acting on a structure (Fig. 2). For a 3D structure as shown in Figure 3, students might use cross-sectioning skills to visualize and

analyze the impact of an eccentric concentrated load and draw 3D stress analysis diagrams on the cross section of the structure.

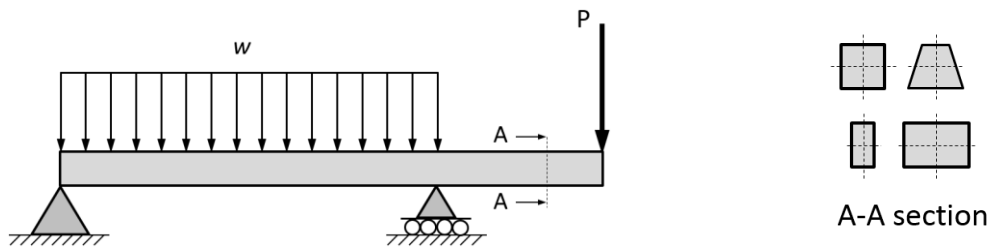

**Figure 1.** Stiffness of structures depends on their cross-sectional profiles and materials.

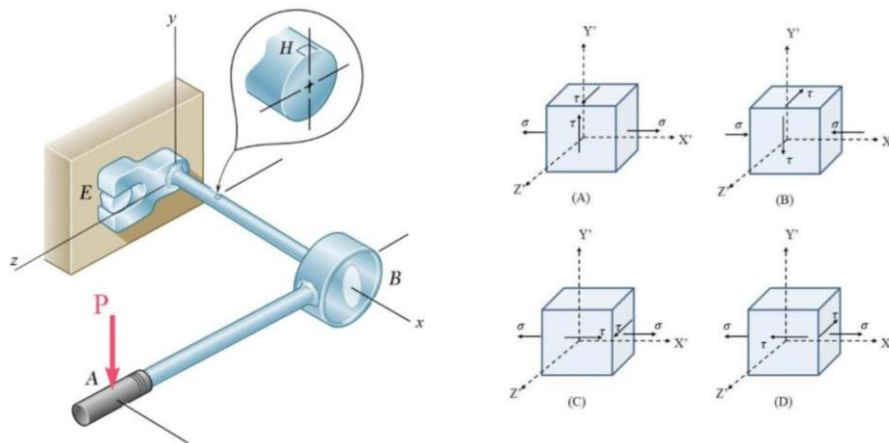

**Figure 2.** A sample problem of solid mechanics with 3D answers, adopted from [15].

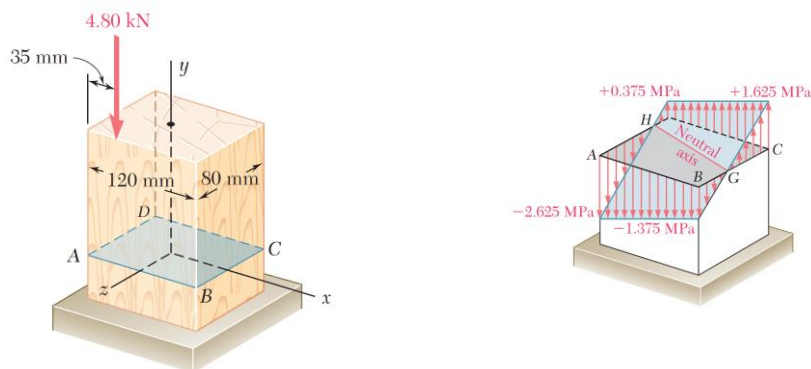

**Figure 3.** Cross-sectioning skill helps students visualize and analyze stress distribution of an eccentric load, adopted from [16].

Although students' cross-sectioning skills affect the way they retrieve spatial information from learning materials and acquire knowledge of the course, the role of this spatial visualization in the learning of MM course has not been investigated adequately. This study investigates the relationship between students' abilities to infer a 2D cross section of 3D objects and their performances on MM conceptual understandings. There are two research questions that this study addresses: 1) What is the relationship between students' performance on the MM course and their cross-sectioning skills? 2) How do students' cross-sectioning skills on different types of geometric objects relate to their scores of MMCI?

### Methods and Procedures

Seventy-three students who took the Mechanics of Materials course during recent academic years at five colleges in the United States participated in the study and took an online survey at the end of the course. The survey includes 23 questions of Mechanics of Materials Concept Inventory (MMCI) to solicit students' basic knowledge of Mechanics of Materials [17] and 30 questions of the Santa Barbara Solid Test (SBST) [18] to assess student's cross-sectioning skills. Students' scores on the MMCI and SBST were then analyzed for trends, central tendencies, and correlations. Implications for spatial visualization training and instructional practices for the course were provided at the end of the study.

The MMCI has been used by many instructors and researchers in the engineering education community and its reliability (measured by Cronbach's alpha) in this study was acceptable (0.70). Figure 4 is a question appearing in the MMCI. Each question of the SBST test measures students' cross-sectioning skills with various geometric structures intersected by cutting planes of different orientations. Figure 5 illustrates one of the item in the SBST. The SBST was reported to have a Cronbach's alpha of 0.86 in a study by Cohen and Hegarty [18]. In this study, the SBST test has a Cronbach's alpha of 0.89.

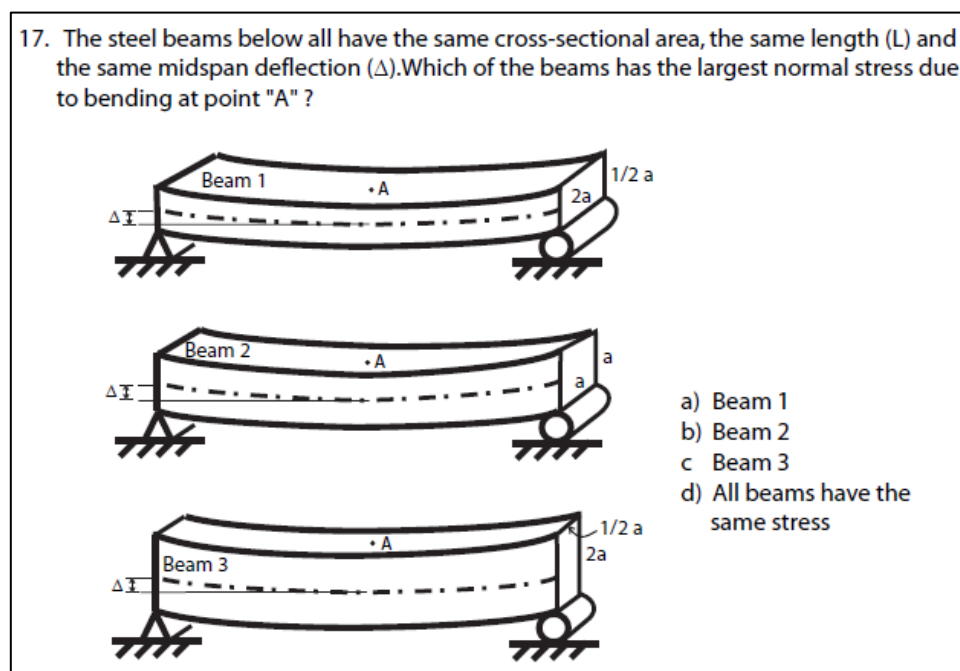
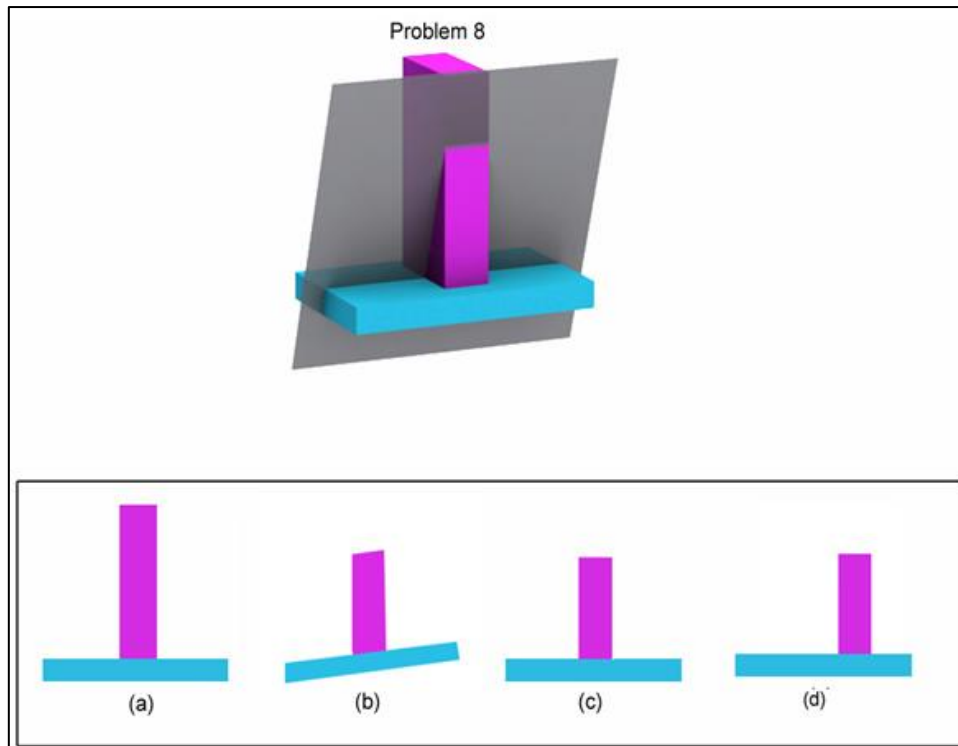

Figure 4. An item in the MMCI



**Figure 5.** An item in the SBST.

## Results and Analysis

### *Descriptive statistics:*

There were 73 students who had completed both the MMCI and SBST tests and their scores were used for the analysis. Most of students (91.8%,  $n = 67$ ) major in CE and ME and a negligible portion of them (8.2%,  $n = 6$ ) study other engineering disciplines. The descriptive statistics of students' scores on MMCI and SBST were presented in Table 1. The scores were reported both in the mean number of correct questions and the mean correct rate. Due to the limited number of students in other engineering fields participating in the study ( $n = 6$ ), the analysis will focus on the relationship between the MM performance and SBST scores of the CE and ME students only.

**Table 1.** Descriptive statistics by engineering field

Test score	N (%)	MMCI Score				SBST Score			
		$M (SD)$	Min.	Max.	Correct Rate ( $SD$ )	$M (SD)$	Min.	Max.	Correct Rate ( $SD$ )
CE	20 (27.4)	11.90 (3.82)	5	19	0.52 (0.17)	22.55 (6.89)	7	30	0.69 (0.21)
ME	47 (64.4)	11.34 (4.00)	2	20	0.49 (0.17)	23.72 (5.68)	5	30	0.74 (0.17)
Other	6 (8.2)	11.50 (3.99)	8	18	0.50 (0.17)	14.83 (9.93)	3	29	0.48 (0.29)
Total	73 (100.0)	11.51 (3.90)	2	20	0.50 (0.17)	22.67 (6.77)	3	30	0.71 (0.20)

Note:  $M$  = mean number of correct questions,  $SD$  = Standard deviation

**Research question 1:** What is the relationship between students' performance on the MM course and their cross-sectioning skills?

In general, students answered correctly 50% of MMCI questions (correct rate = 0.50,  $SD = 0.17$ ) and 71% of SBST questions (correct rate = 0.71,  $SD = 0.2$ ). These performances varied

with the engineering fields that students pursued (Table 1) with CE students had higher mean MMCI and lower mean SBST scores than the ME students. However, the *t* test' results revealed that there were no significant differences between CE and ME students on the MMCI ( $t(65) = 0.53, p = 0.597$ ) and SBST test scores ( $t(65) = -0.94, p = 0.350$ ). Correlational analysis was conducted to better understand the relationship between students' MMCI and SBST scores. There was a positive medium correlation (0.45) between the students' MMCI and SBST scores (Table 2) and this correlation is higher for the CE ( $r(20) = 0.725$ , effect size of 0.526) than for the ME students ( $r(47) = 0.725$ , effect size of 0.305). As a rule of thumb offered by [19] for interpreting the correlation coefficient, a correlation greater than 0.7 was considered as high, from 0.5 to 0.7 as moderate, from 0.3 to 0.5 as low, and less than 0.3 as negligible. Also, under linear regression model, the SBST score can also be used as a predictor for students' MM performance with 35.3% of the variance in the MMCI score (Table 3) can be explained by their cross-sectioning skills. It is more interesting that nearly 50% of the variance of CE students' MMCI score can be explained by their SBST scores, while this number for ME students was only 28.9%.

This finding can be interpreted that the SBST scores can be used to predict students' success of the MM course, or, in other words, a student with high penetrative skill is likely to success the MM course. In addition, the predictive power varies with the student's major. Because the association between CE students' mean SBST and MMCI scores is higher than this for ME students, CE students is more likely to success the MM course than ME students with equivalent penetrative skills. It can also be interpreted that the CE students in this study could be better than ME students in utilizing their visual penetrative skill to gain a higher mean MMCI score.

Table 2 - Correlations between MMCI and SBST scores

		SBST- All students	SBST - CE students	SBST- M&A students
MMCI	Correlation	0.602**	0.725**	0.552**
	Sig. (2-tailed)	0	0	0
	<i>N</i>	73	20	47

\*\* . Correlation is significant at the 0.01 level (2-tailed).

Table 3 - Linear regression results

Dependent variable MMCI	SBST as predictor for all students	SBST as predictor for CE students	SBST as predictor for MAE students
Adjusted $R^2$ value	0.353	0.499	0.289
<i>p</i> value	0	0	0

*Research question 2:* How do students' cross-sectioning skills on different types of geometric objects relate to their scores of MMCI?

To further investigate the relationship between the students' performance of the MM course with different visual penetrative skills, the SBST test was regrouped into subtests depending on the objects' structures (simple = SIM , joined = JOIN, or embedded = EMB) and their intersection with different cutting planes (orthogonal = OR or oblique = OB). For instance, the new subtests included the tasks to identify cross sections of embedded objects with an orthogonal cutting plane (OREMB) or simple objects with an oblique cutting plane (OBSIM), etc. The embedded objects (EMB) are seldom seen in mechanical engineering but are more popular in civil engineering practices, in which, steel reinforcing bars are embedded in the

concrete to increase its tensile strength and ductility. The joined objects (JOIN) are structures or systems of bodies that are usually assembled from simple objects to enhance stiffness and resist deflection and deformation (such as T- and I-shape beams). Table 4 introduces the six most complex SBST subtests, their contents, and the mean correct rates and standard deviations for all students.

It was found that there were no significant differences between the CE and ME students on these subtests (Fig. 6) and, within each group, students' performances were significantly lower on the OREMB subtest ( $p < 0.001$  for CE,  $p = 0.012$  for ME students, Bonferroni adjustment was used due to multiple comparisons) than the others. Except for the OREMB subtest, correlations between the students' SBST subtest scores and their MMCI test scores were found to be low (from 0.32 to 0.46) and statistically significant (Table 5).

Table 4. Six combination SBST subtests, reliabilities, and students' mean scores

Subtest	Questions	Mean correct rate	SD
ORSIM	1, 4, 13, 19, 28	0.76	±0.26
ORJOIN	2, 5, 11, 14, 17	0.83	±0.24
OREMB	6, 12, 18, 21, 24	0.56	±0.14
OBSIM	7, 10, 16, 22, 25	0.73	±0.29
OBJOIN	8, 20, 23, 26, 29	0.69	±0.30
OBEMB	3, 9, 15, 27, 30	0.68	±0.30

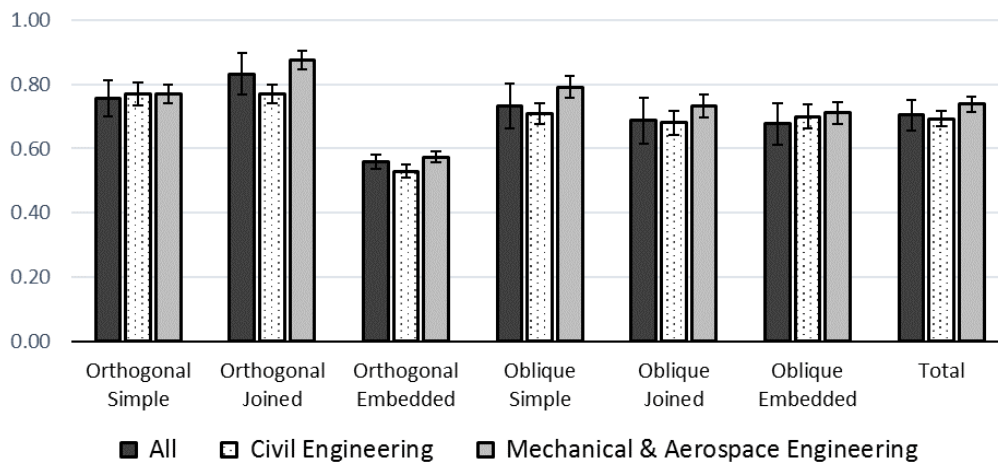

Figure 6 – Student's performance on different cutting scenarios

Table 5. Correlations between MMCI and SBST subtest scores

		ORSIM	ORJOIN	OREMB	OBSIM	OBJOIN	OBEMB
MMCI	All (N = 73)	.408**	.316**	.169	.314**	.464**	.356**
	CE (N = 20)	.581*	.647**	.430	.623**	.591**	.562**
	ME (N = 47)	.560**	.312*	.253	.314*	.561**	.378*

\*. Correlation is significant at the 0.05 level (2-tailed).

\*\*.. Correlation is significant at the 0.01 level (2-tailed).

These correlational analysis's results could be interpreted that ME student's scores on ORJOIN and OBSIM subtests can each explain roughly 10% of the variation of their MMCI score as compared to 42% and 39%, respectively, of the same variation for CE students. This could mean that the cross-sectioning skills for joined objects with an orthogonal plane and simple objects with an oblique plane help CE students learn the MOM course better than these for ME students. Figures 7 and 8 introduce the ORJOIN and OBSIM objects in the SBST and some structural members in the MM course. The complex beams (Fig. 7, right) are formed by joining more than two simple beams (using same or dissimilar materials) together to act as a single unit. For example, the I-shape beam in structural design is created by three rectangular beams to increase the beams' modulus of rigidity.

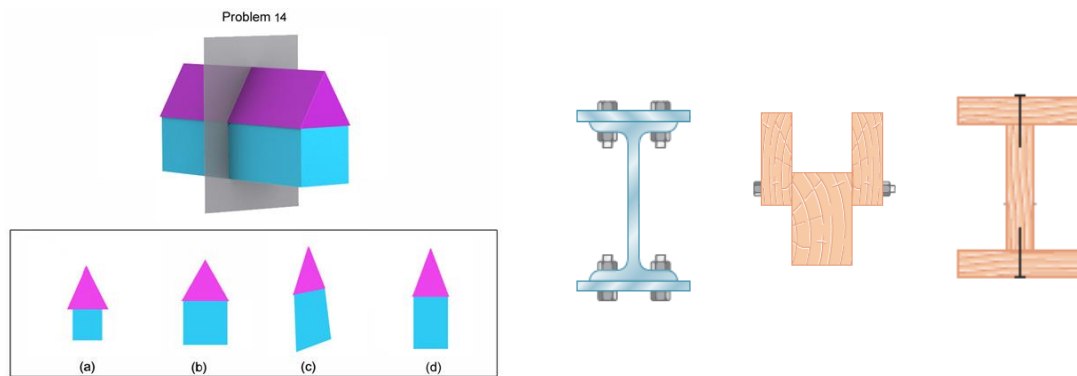

**Figure 7** – An ORJOIN item in the SBST (left) and orthogonal cross sections of different beams in the MM course (adopted from [16]). These structural members were formed by joining (using bolts, nails) two or more simple beams (same or dissimilar materials) together to act as a single unit.

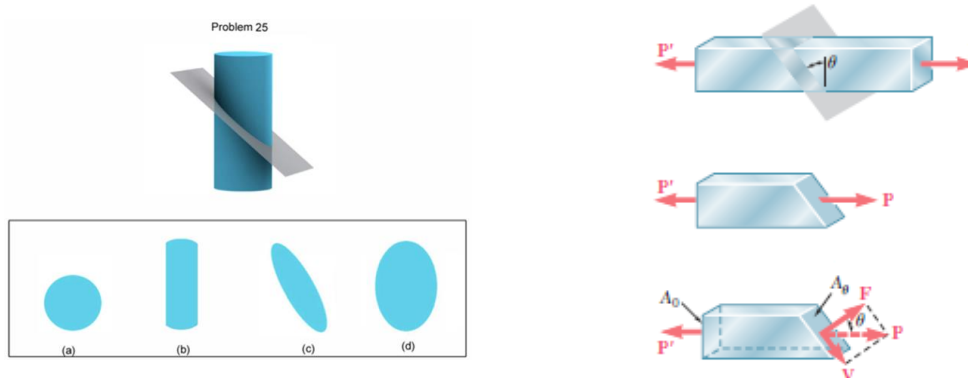

**Figure 8** – An OBSIM item in the SBST (left) and an inclined cross section of a beam in the MM course (adopted from [16]).

### Conclusion

Spatial visualization skills play an important role in developing expertise and success in learning engineering. For MM course, a high spatial visualization skill will help students retrieve spatial information from the engineering structures and systems of bodies. Cross-sectioning skill is a subfactor of spatial visualization skills, and this study showed that students with high cross-sectioning skills are more likely to success the Mechanics of Materials course than the low cross-sectioning ability peers. On average, the students' cross-sectioning skills measured by the SBST explained 35.3% of the variance of their



performances in the MMCI test. However, the predictive power of the cross-sectioning skill on the performance of the MM course varies with the engineering fields, explaining from 29% to 50% of the variance of MMCI test for ME and CE students, respectively. Because CE students had lower mean SBST and higher mean MMCI scores than ME students (although the differences are not significant), it is interpreted from the study that CE students could possibly be better than ME students in utilizing their visual penetrative skill to gain a higher MMCI score. The SBST subtest scores, especially the subtest scores for the orthogonally joined and oblique simple objects, can be used to relate students' engineering fields and their chances of success of the MM course. The CE student' scores on ORJOIN and OBSIM subtests can explain 42% and 39%, respectively, the variation of their MMCI score while the ME students' scores on similar subtests can each explain only 10% of the variation of their MMCI scores. Future research should be conducted with larger sample size and with more diverse participants to validate the study's findings.

## **References**

1. Hegarty, M., & Waller, D. (2005). Individual differences in spatial abilities. In P. Shah, & A. Miyake (Eds.), *The Cambridge Handbook of Visuospatial Thinking* (pp. 121-167). New York, NY: Cambridge University Press.
2. Uttal, D. H. & Cohen, C. A. (2012). Spatial thinking and STEM education: when, why, and how? In B. H. Ross (Ed.), *The Psychology of Learning and Motivation*, 57 (pp. 147-181), Philadelphia, PA: Elsevier.
3. Uttal, D. H., Meadow, N. G., Tipton, E., Hand, L. L., Alden, A. R., Warren, C., & Newcombe, N. S. (2013). The malleability of spatial skills: A meta-analysis of training studies. *Psychological Bulletin*, 139(2), 352-402.
4. Carroll, J. B. (1993). *Human cognitive abilities: A survey of factor-analytic studies*, Cambridge University Press, New York.
5. Hegarty, M., and Waller, D. (2004). "A dissociation between mental rotation and perspective-taking spatial abilities." *Intelligence*, 32(2), 175–191.
6. Lohman, D. F. (1988). "Spatial abilities as traits, processes, and knowledge." *Advances in the psychology of human intelligence*, R. J. Sternberg, ed., Vol. 4, Psychology Press, New York, 181–248.
7. Maeda and Yoon 2013
8. Sorby, S., Casey, B., Veurink, N., & Dulaney, A. (2013). The role of spatial training in improving spatial and calculus performance in engineering students. *Learning and Individual Differences*, 26, 20-29.
9. Gorska, R., & Sorby, S. (2008). Testing instruments for the assessment of 3-D spatial skills. In *Proceedings of the American Society for Engineering Education Annual Conference*.
10. Branoff, T., & Dobelis, M. (2013, June). The relationship between students' ability to model objects from assembly drawing information and spatial visualization ability as measured by the PSVT: R and MCT. In the 120th ASEE Annual Conference and Exposition (pp. 1-9).
11. Guay, R. (1976). *Purdue spatial visualization test*, Purdue University Press, Lafayette, IN.
12. Vandenberg, S. G., and Kuse, A. R. (1978). "Mental rotations, a group test of three-dimensional spatial visualization." *Perceptual Motor Skills*, 47(2), 599–604
13. Ekstrom, R. B., French, J. W., Harman, H. H., & Dermen, D. (1976). *Manual for kit of factor-referenced cognitive tests*. Princeton, NJ: Educational testing service.
14. CEEB Special aptitude test in spatial relations, College Entrance Examination Board, USA, 1939
15. Bi, Y., & Reid, T. N. (2014, June), *Understanding Students' Process for Solving Engineering Problems Using Eye Gaze Data Paper* presented at 2014 ASEE Annual Conference, Indianapolis, Indiana.
16. Beer, F. P., Johnston, E. R., DeWolf, J. T., & Mazurek, D. F. *Mechanics of Materials*, 6th ed. New York: McGraw Hill; 2012.
17. Richardson, J., Steif, P., Morgan, J., & Dantzler, J. (2003, November). Development of a concept inventory for strength of materials. In *Frontiers in Education*, 2003. FIE 2003 33rd Annual (Vol. 1, pp. T3D-T3D). IEEE.
18. Cohen, C. A., & Hegarty, M. (2012). Inferring cross sections of 3D objects: A new spatial thinking test. *Learning and Individual Differences*, 22(6), 868-874.
19. Hinkle, D. E., Wiersma, W., & Jurs, S. G. (2003). *Applied statistics for the behavioral sciences*.