AC 2012-3915: STRUCTURING A SYSTEM DESIGN LABORATORY COURSE TO FACILITATE OUTCOMES ASSESSMENT

Prof. Victor P. Nelson, Auburn University

Victor P. Nelson is a professor and Assistant Chair of electrical and computer engineering at Auburn University. His primary research interests include embedded systems and computer-aided design and testing of digital systems and application-specific integrated circuits (ASICs). He is co-author of the textbook *Digital Logic Circuit Analysis and Design* and a tutorial book on fault-tolerant computing. He has been Chair of the ECE Curriculum Committee, Coordinator of the ECE Graduate Program, and served one year as Associate Dean for Assessment in the College of Engineering. He is a member of IEEE, ACM, and ASEE, and is an ABET Program Evaluator. He has served as Chair of the ECE Division of ASEE, an at-large AdCom member of the IEEE Education Society, a member of the IEEE Committee on Engineering Accreditation Activities (CEAA), and previously served as an Associate Editor of the *IEEE Transactions on Education* and on the IEEE Computer Society/ACM Task Force that developed the *Computer Engineering 2004* report on model computer engineering curricula. He was a co-winner of the 2005 Wireless Educator of the Year Award from the Global Wireless Education Consortium for his role as one of the developers of the bachelor's of wireless engineering program at Auburn University, which is the first of its kind in the U.S.

Prof. John Y. Hung, Auburn University

John Y. Hung is a professor of electrical and computer engineering at Auburn University, where he has been on the faculty since 1989. Prior to his academic career, he worked for Johnson Controls, Inc., in the field of digital controllers for commercial building automation systems, and also worked as a consultant in control systems design. Hung is a Fellow of IEEE, and is President-elect of the IEEE Industrial Electronics Society (IES). Previously, he served IES as Treasurer and Vice President for Conference Activities. He served as General Co-chair for the 2008 IEEE Industrial Electronics Conference (IECON-2008) and the 2010 IEEE International Symposium on Industrial Electronics (ISIE-2010). His teaching and research interests are in control systems applications.

Structuring a System Design Laboratory Course to Facilitate Outcomes Assessment

ABSTRACT

Assessment and evaluation of student learning are key components of a successful educational program. An effective assessment process must produce useful data that are both summative and formative, the former to determine levels to which student outcomes are being attained, and the latter to identify specific areas for program improvement. In addition, the assessment process must be efficient, to ensure sustainability. This paper discusses how the junior-level embedded systems design laboratory course in the electrical and computer engineering programs has been structured to provide a significant system design experience, while providing opportunities for students to demonstrate, and for faculty to assess, achievement of six of the eleven student outcomes defined for their respective programs, including both technical and professional skills. Several program improvements resulting from this assessment process are also discussed.

I. Introduction

Assessment and evaluation of student learning are key components of a successful educational program. As defined by ABET, “student outcomes describe what students are expected to know and be able to do by the time of graduation.” [1] An effective assessment process must produce useful data that are both summative and formative, the former to determine levels to which student outcomes are being attained, and the latter to identify specific areas for program improvement [2,3]. In addition, the assessment process must be efficient, to ensure sustainability. The program must identify or create opportunities to assess each of its student outcomes at one or more points in the program, where students are expected to have attained, and should be able to demonstrate that outcome at an acceptable level.

The junior-level embedded systems design laboratory courses [4] in the electrical engineering (EE) and computer engineering (CPE) programs have been structured to provide a significant system design experience, while providing opportunities for students to demonstrate, and for faculty to assess, achievement of six of the eleven student outcomes defined for their respective programs, including both technical and professional skills. These courses serve as prerequisites for the senior-level capstone design course. The EE course is ELEC 3040, “Electrical System Design Lab”, and the CPE course is ELEC 3050, “Embedded System Design Lab”. The system design projects in these courses require students to apply knowledge gained across the breadth of earlier courses, including the ability to design systems containing both hardware and software. In addition, there is significant emphasis on interpersonal skills needed for professional practice, including written and oral communication, documenting engineering work, multidisciplinary teamwork, and engineering ethics. The EE and CPE courses were originally taught separately. However, three years ago it was determined that the two courses had evolved to where they had similar goals, projects, and outcome assessments. Therefore, the decision was made to combine these into a single course, in which EE students are normally paired with CPE students in two-person teams. The separate course listings have been maintained, due to the different prerequisite

structures of the EE and CPE curricula. For example, EE students study control systems while CPE students study software design and operating systems.

The next section will provide an overview of the course projects. The remaining sections will discuss how course requirements and assignments have been structured to facilitate program assessment within the normal course grading process.

II. Course Projects

The course is structured around the design of an embedded system, typically a microcontroller-based speed controller for a dc motor, pictured in Figure 1. A typical 14-week lab schedule is given in Figure 2. Each week begins with a common introductory session on Monday, after which students prepare initial designs in their engineering notebooks. Experiments are conducted later in the week in lab sections of 12 students, with students working in two-person teams. Reports and lab notebooks are submitted on Friday.

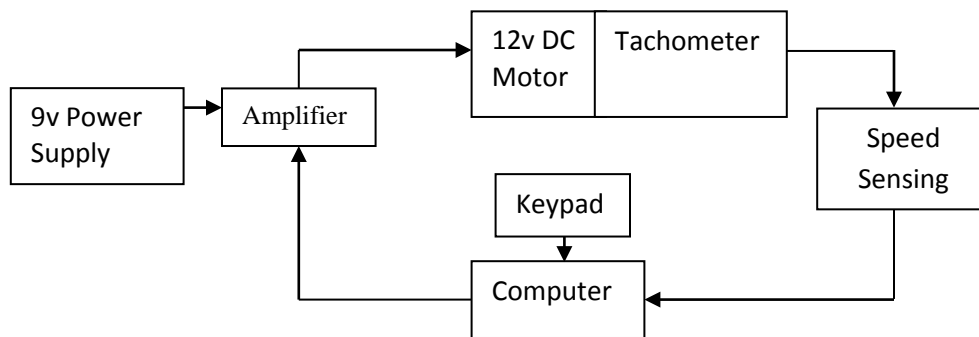

Figure 1. Motor speed controller system designed in ELEC 3040/3050

- Weel 1. Software development and debugging with CodeWarrior for the MC9SC128 “DragonFly12 Plus” module; EEBOARD platform; engineering documentation.
- Weel 2. Parallel inputs/outputs; C program design and debug
- Weel 3. System debugging with test instruments (oscilloscope, logic analyzer)
- Weel 4. Interrupt setup and service routines in C
- Weel 5. Keypad parallel I/O interface
- Weel 6. Real-time operation with programmable interval timer and interrupts.
- Weel 7. PWM waveform generation with the programmable interval timer or PWM generator.
- Weel 8. BJT switch to drive a dc motor
- Weel 9. Motor speed sensing: tachometer frequency counting.
- Weel 10. Motor speed sensing: tachometer amplitude measurement.
- Weel 11. Motor characterization (step response).
- Weel 12. Monday session: Engineering ethics. Lab - Work on feedback controller.
- Weel 13. Monday session: Effective communication. Lab - Continue work on feedback controller.
- Weel 14. Monday session: Course evaluation. Lab - Final Project presentations and demos.

Figure 2. Project schedule for the 14-week lab course.

Lab projects have been structured to lead students through the system design process, with design projects and experiments becoming more open-ended as the semester progresses. The first six weeks are devoted to learning the development environment, system debugging methods, and embedded system design concepts, such as input/output, interrupts and timers. Over the next four weeks, the system shown in Figure 1 is developed. The motor is driven by an amplified PWM signal, with motor speed measured from a tachometer signal. Students experiment with multiple methods for generating the PWM signal and measuring motor speed, and select what they determine to be the best approaches for their final design. In the last few weeks, students must design experiments to characterize their motor, design a feedback controller that meets a set of given performance constraints, and then demonstrate that their design meets these constraints.

The development environment includes a Freescale MC9S12C32 microcontroller, mounted on the 40-pin DIP “DragonFly12-Plus” module from EVBPlus.com, Freescale’s *CodeWarrior* Integrated Development Environment, USB Background Debug Module, and a Digilent *Electronics Explorer Board* (EEBOARD), which integrates breadboard, power supply, and instrumentation. Each team of two students is provided with a kit that contains their EEBOARD and related components. Detailed information on the lab projects and development environment, including weekly presentations, are available on the course web site [4].

III. Assessing Student Outcomes

The eleven student outcomes of the EE and CPE programs are essentially identical, and are based on ABET Criterion 3 (a)-(k) and the IEEE program criterion [1]. These outcomes are listed on the two program web sites [5,6]. While the knowledge and skills defined in most of these outcomes are exercised in this system design lab, the ECE Curriculum and Assessment Committee (ECAC) determined that achievement of the following five student outcomes should be effectively demonstrated and assessed in this course.

Outcome 3. Ability to design an electrical component or system (including hardware and software elements) to meet desired needs.

Outcome 5. Ability to design and conduct experiments to acquire needed data, and to analyze and interpret data to solve engineering problems.

Outcome 7. Ability to function as a member of a multidisciplinary team in the solution of engineering problems.

Outcome 8. Proficiency in communicating ideas and information orally and in writing.

Outcome 10. Understanding of ethical responsibility and professional integrity issues related to the practice of electrical (computer) engineering.

To ensure that achievement of outcomes by students in both the EE and CPE programs is adequately assessed and evaluated, all assessment data is separated by major prior to evaluation. To determine levels of achievement and provide formative assessment data, performance indicators and rubrics have been designed for each student outcome by the ECAC. These were

based on notes and examples presented in the IDEAL workshop [2] and other resources provided on the ABET web site [3], and are available on the ECE Department web site [6]. The rubrics for the outcomes listed above are also included in the Appendix. The ECAC annually identifies one or more key courses in which selected outcomes should be demonstrated and assessed, and provides instructors with the rubric forms. For example, this course is the primary place in the curriculum for assessment of Outcomes 5 and 10, while Outcomes 3, 7 and 8 are also assessed in the capstone design project course. Instructors apply the rubrics to selected student work and submit a summary of their assessment data to the ECAC for evaluation and determination of potential program improvements. The use of ECAC-defined rubrics ensures uniformity of the assessment process across all courses and instructors.

In the ELEC 3040/3050 course, to maximize the efficiency and effectiveness of the assessment process, the rubrics for each performance indicator are applied as part of the regular course grading process, rather than as separate assessment activities, with each student outcome contributing to the course grade. All rubrics are provided to the students in advance, on the course web site, so they are aware of the knowledge and skills they are expected to demonstrate, and how they will be evaluated. After assessment has been completed, the data are summarized for the ECAC, and the assessment forms are given to the students to provide feedback they can use for improvement.

When this assessment process was first adopted, it was noted that some outcomes were difficult to assess from the student work. In many cases, it was difficult to identify where to assess certain performance indicators, leading to results that were not as meaningful as they should have been. Consequently, the course instructors made some relatively simple changes to course assignments to ensure that students provide evidence of achievement of each of the desired performance indicators. This serves both to facilitate assessment and to emphasize to the students what they are expected to know and be able to do. The following sections describe how this has been done in ELEC 3040/3050.

IV. Course assignments and assessment

In the past few years, Auburn University has emphasized writing across the curriculum. Each program in the university has been required to submit a plan for writing within the major courses, with students expected to gain writing experience in several formats. To this end, a variety of writing activities have been designed for ELEC 3040/3050, both to ensure that each student demonstrates the ability to communicate in writing and that each student provides evidence of achievement of the other outcomes to be assessed in the course. Since the intent is to measure individual student achievement of outcomes, all writing assignments are individual, rather than team efforts, even though projects are done in teams. These assignments, and the corresponding outcomes assessment activities, are as follows.

1. Engineering notebook: As might be expected in professional practice, each student is required to maintain a record of all lab-related activities in an engineering notebook, including notes, designs, experiments, results, etc. The notebooks are collected every two weeks and evaluated by graduate teaching assistants, who provide constructive feedback.

2. Bi-weekly memos: Two-page memos summarize each team's progress over a two-week period. Every student writes a memo in the first week, allowing the instructors to provide constructive feedback that can be applied to future writing. Subsequently, the two students alternate writing the bi-weekly memo for their team.
3. Midterm report: This is a more substantial report that describes some aspect of the system design project, including the design itself and at least one experiment performed to evaluate the design. Ideally, we would like students to submit a draft paper and then revise it to incorporate instructor feedback. Since there is insufficient time at the end of the semester to do this for the final report, the midterm report is used as an opportunity for instructors to provide feedback to students on their writing, which they are then expected to incorporate into their final reports.
4. Final report: With students having received significant instructor feedback on multiple writing assignments throughout the semester, including the midterm report, the final report is used for assessment of three student outcomes. In addition to writing skills (Student Outcome 8), students are expected to provide evidence of their ability to design a system (Student Outcome 3), and to conduct experiments, and analyze and interpret data (Student Outcome 5). Therefore, the final report is graded using the performance indicators and rubrics for these three outcomes, provided in the Appendix. These rubrics are posted on the course web site, so students know in advance what is expected. The sum of the scores for all performance indicators for these three outcomes make up the final report grade, with the results also submitted to the ECAC as part of the program assessment process. The marked up reports and all assessment forms are returned to the students as feedback to be used in future work. The rubrics are applied as follows.
 - Outcome 8: Writing is assessed using the written communication rubric in the Appendix. Six performance indicators are assessed by both instructors, who mark the appropriate columns on the rubric form. These scores determine the writing component of the final report grade.
 - Outcome 3: System Design Ability. In the midterm and final reports, students must discuss some element of their system design, addressing the five performance indicators on the design rubric provided in the Appendix. Specifically, they must discuss how they created the design to meet the given requirements, how they dealt with constraints, and how they constructed, tested, and evaluated their design. Informal feedback was provided on the midterm report. After studying the final report, instructors rate each of the performance indicators on the design rubric form. These scores determine the design component of the final report grade.
 - Outcome 5: Experimentation and Data Analysis Abilities. In the midterm and final reports, students must discuss how they designed and conducted an experiment to evaluate the design discussed in the first part of the report, present experimental results, evaluate the results, and provide some conclusions. After reading the final report, the experimentation rubric form in the Appendix is marked by the instructors, with the scores determining the experimentation component of the final report grade.

5. Engineering ethics case study paper (Student Outcome 10): This is assigned after a classroom discussion of engineering ethics, following the last technical presentation of the semester and while students are working on their final feedback control system designs. Each student is required to find, read, and prepare a four-page paper on an engineering ethics case study from an IEEE, ASEE, or similar journal or conference article. In this paper, students are expected to address the performance indicators on the ethics rubric form in the Appendix, demonstrating that they can identify an ethical dilemma, explain the dilemma, suggest possible solutions to the dilemma, and relate the ethical dilemma to the IEEE Code of Ethics.
6. Final Project Presentation (Student Outcome 8): In the final week of the semester, each team makes an oral presentation of their final design, with students expected to speak equal amounts of time. The oral communication rubric in the Appendix is marked separately for each student by two course instructors and a graduate teaching assistant, assessing five performance indicators. The presentation grade is calculated from the average score on the three forms, with all forms returned to the students as feedback for future improvement, and with the results forwarded to the ECAC as part of the program assessment process.
7. Multidisciplinary Teamwork (Student Outcome 7): The teamwork component of the course grade is based on two evaluations. One is an assessment of teamwork by the graduate teaching assistants, who observe the teams in their sections from week to week. The second is a peer and self-evaluation by each student, using the teamwork assessment rubric form in the Appendix. The scores from these forms are summarized and submitted to the ECAC as part of the program assessment process.

V. Results and Conclusions

The adoption of the assessment procedure described above has yielded a number of benefits. First, the assessment process has been made more efficient by incorporating program assessment into the regular course grading process. Second, the assessment has become more effective by having students organize their reports to present evidence of achievement of each performance indicator defined for each student outcome. Providing the rubrics to the students at the beginning of the course has made them better informed of the skills and knowledge they are expected to demonstrate. This, in turn, has resulted in improved overall performance in the course.

For example, assessment data indicated that students were not achieving acceptable levels of performance on Student Outcome 5. Assessment scores were lower than desired on three of the four performance indicators: “ability to design experiments”, “ability to analyze data”, and “ability to interpret data”. We found it common for many students to make such statements as “the design worked great”, with little or no supporting data. In some cases, experiments were not being designed to gather appropriate data, whereas in other cases, data was gathered but not effectively presented, analyzed and/or interpreted. In response to these assessment results, the instructors decided to allocate time in two lecture sessions to discuss these issues. Then, in the midterm and final reports, in addition to describing a design, students are now required to

describe an experiment they designed and conducted during their design process, including presentation, analysis and interpretation of experimental data. To help them understand what was expected, students were provided the rubrics in the appendix, the performance indicators were explained, and the students were told that these would be used in grading their reports. The instructors provide feedback on the midterm report so they can improve both their processes and their discussions for the final report. As a result, assessment results have improved, indicating that students are now doing a better job of designing experiments to collect appropriate data to demonstrate characteristics of a designed system, and are doing better at comparing experimental data to expected results and/or required performance parameters.

Improved performance has also been observed in written reports, both because of the feedback that is provided throughout the semester and because students are paying closer attention to the performance indicators being measured in their writing. This improvement has also been noted in the writing assessment results for the subsequent senior capstone design course.

References

1. ABET, Inc., "Criteria For Accrediting Engineering Programs, Effective for Evaluations During the 2011-2012 Accreditation Cycle", Oct. 30, 2010.
2. Rogers, Gloria, "The Institute for the Development of Excellence in Assessment Leadership (IDEAL)", Baltimore, MD, August, 2009.
3. ABET, "Assessment Planning Resources", <http://www.abet.org/assessment-planning-resources/>
4. ELEC 3040/3050 Course Web Site:
http://www.eng.auburn.edu/~nelsovp/courses/elec3040_3050/
5. Auburn University Electrical Engineering Program Web Site:
<http://www.eng.auburn.edu/elec/programs/undergraduate/ee/index.html>
6. Auburn University Computer Engineering Program Web Site:
<http://www.eng.auburn.edu/elec/programs/undergraduate/ce/index.html>
7. Auburn University ECE Department Student Outcomes Assessment Forms:
<http://www.eng.auburn.edu/elec/programs/ece-department.html>

APPENDIX – STUDENT OUTCOMES RUBRICS USED IN ELEC 3040/3050

Program Outcome 3: Graduates will demonstrate ability to design an electrical component or system to meet desired needs within the field of wireless engineering

		Rubric			
		1 – Unsatisfactory	2 – Developing	3 – Meets expectations	4 – Exceeds expectations
Performance Indicators	Use knowledge, methods, processes and tools to create a design that meets stated requirements	Can't combine and integrate knowledge, methods, processes and tools to create a design.	Can partially combine and integrate knowledge, methods, processes and tools to create a design.	Can fully combine and integrate knowledge, methods, processes and tools to create a design.	Can fully combine and integrate knowledge, devise new or alternate methods, processes and tools to create a design.
	Evaluate if a design meets desired needs	Does not verify design against desired needs or design does not respond to desired needs.	Partially verifies design against desired needs or design partially complies with desired needs.	Design is verified against desired needs and complies with most desired needs.	Design fully complies with desired needs or even exceeds the expressed needs.
	Consider realistic constraints in the design	Does not consider constraints of any kind.	Considers some constraints, but does not deal with realistic constraints, or does so weakly.	Considers at least one realistic constraint, and deals with it appropriately.	Considers more than one realistic constraint, and deals with them effectively.
	Testing of the final design	Conducts no meaningful tests of the design	Conducts some appropriate tests, but only partial or incomplete.	Conducts reasonable testing of the design.	Develops innovative and complete tests of the design.
	Constructing a prototype of the design	Is unable to construct a reasonable prototype of a design.	Is able to construct partial prototypes of a design, but not an entire system.	Is able to construct a complete working prototype of a design.	Is able to construct a complete working prototype that demonstrates exceptional quality

Program Outcome 5: Graduates will demonstrate ability to design and conduct experiments to acquire needed data, and to analyze and interpret data to solve engineering problems.

		Rubric			
		1 – Unsatisfactory	2 – Developing	3 – Meets expectations	4 – Exceeds expectations
Performance Indicators	5(a) Ability to design experiments				
	Identify experiment goals and draw a hypothesis	Can't identify goals nor draw any hypotheses	Can identify some goals but unable to draw an adequate hypothesis	Can identify necessary and sufficient goals and draw adequate hypotheses.	Can identify goals that extend the original scope of the experiment and draw multiple testable hypotheses.
	Describe the experimental process and methods	Is unaware of applicable experimental process and methods.	Can describe some experimental process and methods, but does not know if these are applicable.	Can describe one set of applicable and sufficient experimental processes and methods.	Can generate multiple applicable experimental processes and methods.
	Specify procedures, equipment, tools, and materials	Is unable to specify a viable procedure, a list of materials, or list of equipment necessary for the experiment.	Is able to partially specify a procedure, a list of materials, or list of equipment necessary for the experiment.	Is able to fully specify a procedure, a list of materials, or list of equipment necessary for the experiment.	Is able to produce multiple alternate procedures, and list of materials, or list of equipment necessary for the experiment.
	5(b) Ability to conduct experiments				
	Follow the procedure	Doesn't follow procedure	Follows most of the procedures with some errors or omissions	Follows the procedure to the letter	Follows procedure and is able to identify ways to simplify procedure or develop alternate procedure
	Setup of experiment	Can't set up experiment without assistance.	Can set up most of the experiment without assistance.	Can set up the experiment without assistance.	Identifies alternate ways to set up the experiment.
Take organized and accurate measurements	Can't take measurements.	Can take measurements, but either unorganized or inaccurately.	Takes organized and accurate measurements.	Can identify new ways to improve measurement organization and/or accuracy.	
Performance Indicators	5(c) Ability to analyze data				
	Summarize findings and compare actual to expected results	Can't summarize findings or compare findings to expected results.	Summarizes findings in an incomplete way and can make full sense of the data	Summarizes findings in a complete way; can compare these to expected results.	Summarizes new data and invents ways to compare to expected results.
	Reduce and display result data to facilitate analysis	Doesn't demonstrate knowledge of data reduction techniques, nor of data display techniques.	Applies some of the relevant data reduction techniques and uses some standard display techniques.	Can apply the relevant data reduction techniques and all applicable display techniques.	Invents new data reduction techniques or new data display and visualization techniques.
Performance Indicators	5(d) Ability to interpret data				
	Extract conclusions from analysis	Can't reach meaningful conclusions from analysis of reduced experimental data.	Can extract most of the valid conclusions for the experiment.	Can extract all relevant and valid conclusions from the experiment.	Can use conclusions to propose new questions and experiments.

Program Outcome 8: Proficiency in communicating ideas and information orally and in writing.

ELEC 4000 – Senior Design Final Report
 ELEC 3040/3050/3060 – Midterm and Final Lab Reports
 ELEC 3030 – Final Lab Report

		Rubric			
		1 – Unsatisfactory	2 – Developing	3 – Meets expectations	4 – Exceeds expectations
Performance Indicators	Content	Inconsistent or few details that may interfere with the meaning of the text.	Some details, but may include extraneous or loosely related material.	Provides adequate supporting detail to support solution/argument.	Provides ample supporting detail to support solution/argument.
	Organization	Little evidence of organization or any sense of wholeness and completeness.	Little completeness and wholeness, though organization is attempted.	Organizational pattern is logical and conveys completeness and wholeness with few lapses.	Organizational pattern is logical and conveys completeness and wholeness.
	Style	Limited or inappropriate vocabulary for the intended audience and purpose.	Limited and predictable vocabulary, perhaps not appropriate for intended audience and purpose.	Uses effective language and appropriate word choices for intended audience and purpose.	Uses effective language; makes engaging, appropriate word choices for audience and purpose.
	Grammar	Does not follow rules of standard English.	Generally does not follow the rules for standard English.	Generally follows the rules for standard English	Consistently follows the rules of standard English.
	Figures/Tables	Figures and tables do not support the text, or are poorly designed.	Figures and tables sometimes support the text, and sometimes well designed.	Figures and tables generally support the text, and are usually well designed.	Figures and tables always support the text, and are well designed.
	Use of sources	Sources consistently not cited for material used in the report.	Sources not cited for some material used in the report, or inappropriate sources cited.	Sources cited for material used in the report. Most of the sources are appropriate to support the discussion.	Sources cited for material used in the report. All sources support the discussion.

COMMENTS:

ELEC 3040/3050/4000 Presentation Rubric

Student Name _____

Talk start time: _____ End time: _____ Duration: _____ Course Section _____

Other comments:

		Rubric			
		1 – Unsatisfactory	2 – Developing	3 – Meets expectations	4 – Exceeds expectations
Performance Indicators	Elocution	Volume too soft Often mumbles or cannot be understood Mispronounces many words	Loud enough 60% of the time Speaks clearly 60% of time Mispronounces 3-4 words	Loud enough 80% of the time Speaks clearly 80% of the time Mispronounces 1-2 words	Loud enough all the time Speaks clearly all the time Mispronounces no words
	Enthusiasm	Shows no interest in topic No facial expression or body language	Shows mostly negative attitude towards topic Facial expressions or body language absent or phony	Shows mostly positive attitude towards topic Facial expression and body language sometimes indicate enthusiasm towards topic	Shows strong, positive attitude toward topic Facial expression and body language indicate enthusiasm towards topic
	Eye contact	No eye contact with audience Report read from notes	Minimal eye contact with audience Much of report read from notes	Mostly maintains eye contact with audience frequent use of notes	Consistent eye contact with audience Rarely looks at notes
	Visual aids	Fonts hard to read >4 spelling/grammar errors Graphics hard to read Graphics often detract from content	Fonts mostly hard to read 2-4 spelling/grammar errors Graphics often hard to read Graphics sometimes detract from content	Fonts mostly easy to read 1 spelling/grammar error Graphics mostly easy to read Graphics mostly support content	Fonts easy to read Correct spelling/grammar Graphics easy to read Graphics supports content
	Content	Shows poor understanding of topic Inappropriate for audience Contains several factual errors	Shows a poor understanding of most parts of topic Audience unable to follow much of talk and learned little Contains 1-2 factual errors	Shows a good understanding of most parts of topic Audience understood most of talk but learned little Contains one factual error	Shows full understanding of topic Audience understood most of talk and learned something No factual errors

Program Outcome 7: Graduates will demonstrate ability to function as a member of a multidisciplinary team in the solution of engineering problems.
 Target courses: ELEC 3040 Lab (ELEC), ELEC 3050 Lab (ECPE), ELEC 4000 (All) – Peer review forms.

Lab Partner Evaluation: Partner Name: _____

		Rubric			
		1 – Unsatisfactory	2 – Developing	3 – Meets expectations	4 – Exceeds expectations
Performance Indicators	Research and gather information	Does not collect any information that relates to the topic.	Collects very little information – some relates to the topic.	Collects some basic information – most relates to the topic.	Collects a great deal of information – all relates to the topic.
	Fulfill team role’s duties	Does not perform any duties of assigned team role.	Performs very little duties of assigned team role.	Performs nearly all duties of assigned team role.	Performs all duties of assigned team role.
	Share in the work of the team	Always relies on others to do the work.	Rarely does the assigned work – often needs reminding.	Usually does the assigned work – rarely needs reminding.	Always does the assigned work with without having to be reminded.
	Listen to other teammates	Is always talking – never allows anyone else to speak.	Usually does most of the talking – rarely allows others to speak.	Listens, but sometimes talks too much.	Listens and speaks a fair amount.
	Cooperative with teammates	Usually argues with teammates	Sometimes argues	Rarely argues	Never argues with teammates.
	Make fair decisions	Usually wants to have things their own way.	Often sides with friends instead of considering all views.	Usually considers all views.	Always helps team to reach a fair decision.
	Receptive to feedback from team members from other disciplines or backgrounds	Doesn't accept feedback and/or positive criticism.	Sometimes doesn't accept feedback from other team members.	Most of the time accepts positive comments from other team members.	Shows receptive to feedback from other team members and uses it to improve the quality of the work performed.
	Express alternate points of view, based on a multidisciplinary perspective	Never expresses alternative points of view.	Sometimes expresses alternative points of view.	Usually expresses alternative points of view.	Has no problem expressing alternative points of view wherever there is an opportunity for it.

List one or two “strengths” of your teammate:

List one or two teamwork skills that your teammate could improve:

Program Outcome 10: Graduates will demonstrate understanding of ethical responsibility and professional integrity issues related to the practice of electrical/computer engineering.

Target courses: ELEC 3040 (ELEC majors) – Ethics case study paper.
 ELEC 3050 (ECPE majors) – Ethics case study paper.

		Rubric			
		1 – Unsatisfactory	2 – Developing	3 – Meets expectations	4 – Exceeds expectations
Performance Indicators	Has knowledge of the IEEE Code of Ethics	Unaware of existence of the Code, cannot discuss elements of the Code.	Aware of, and can discuss some aspects of the Code, but incompletely or inappropriately.	Aware of, and can identify and discuss how to apply the Code to practice.	Provides unique insights in the application of the Code to practice.
	Can recognize an ethical dilemma	Unable to recognize a situation as an ethical dilemma.	Recognizes only some obvious situations that pose ethical dilemmas; unable to recognize others.	Recognizes most situations that pose ethical dilemmas.	Recognizes any situation that poses an ethical dilemma.
	Can explain an ethical dilemma	Unable to explain any issues involved in an ethical dilemma.	Explains some issues, but incompletely or inappropriately.	Adequately explains the issues involved in an ethical dilemma.	Provides unique insights into the issues involved in an ethical dilemma.
	Can discuss possible solutions to an ethical dilemma	Unable to offer possible solutions to an ethical dilemma.	Offers solutions, but may not be appropriate or applicable for a particular ethical dilemma.	Offers and explains at least one reasonable solution to an ethical dilemma.	Offers multiple solutions to an ethical dilemma, and discusses tradeoffs.