

# **AC 2008-2550: STUDENT DESIGN PROJECTS IN A PROGRAMMABLE LOGIC CONTROLLER (PLC) COURSE**

**Liping Guo, Northern Illinois University**

**Recayi "Reg" Pecen, University of Northern Iowa**

# **Design Projects in a Programmable Logic Controller (PLC) Course in Electrical Engineering Technology**

## **Abstract**

A Programmable Logic Controller (PLC) is a specialized computer used for the control and operation of manufacturing process and machinery. A junior/senior level PLC course in a four-year electrical engineering technology institution mainly covers the following topics: PLC hardware components, developing fundamental PLC wiring diagrams, basics of PLC programming, timers, counters, program control instructions, data manipulation instructions, math instructions, sequencer and shift register instructions, PLC installation, editing and troubleshooting. After the lectures, students practice PLC programming using RSLogix® from Rockwell Automation. Students are able to observe the operation of the program and make necessary modifications as necessary. Towards the end of the semester, students have learned the basic PLC programming instructions. It is a good time to enhance their practical problem solving abilities by working on an extensive design project using PLCs. This paper discusses three separate design projects aided with PLCs to solve practical process and machinery problems in industrial environments.

## **Introduction**

A programmable Logic Controller (PLC) is a specialized computer used for the control and operation of manufacturing process and machinery<sup>1</sup>. It uses a programmable memory to store instructions and execute functions including on/off control, timing, counting, sequencing, arithmetic, and data handling<sup>2</sup>.

Programmable Logic Controllers (PLC) are used in almost every aspect of industry to expand and enhance production. Where older automated systems would use hundreds or thousands of electromechanical relays, a single PLC can be programmed as an efficient replacement<sup>3-5</sup>. The functionality of the PLC has evolved over the years to include capabilities beyond typical relay control. Sophisticated motion control, process control, distributive control systems, and complex networking have now been added to the PLC's functions. Therefore, PLCs provide many advantages over conventional relay type of control, including increased reliability, more flexibility, lower cost, and communication capability, faster response time and easier to troubleshoot<sup>6</sup>.

## **PLC Course Description**

The PLC course is a junior/senior level course in a four-year electrical engineering technology institution. The main objectives of the course are:

- Identify and explain the purpose of the parts of a programmable logic controller
- Use basic PLC relay instructions to write, debug and troubleshoot ladder logic programs
- Develop and demonstrate programs showing how the timer and counter functions are integrated to a PLC

- Properly use program control instructions
- Properly use math and data manipulation instructions
- Describe and use immediate input and output instructions
- Interface digital and analog devices to PLCs
- Explain the need and process for troubleshooting PLC controlled systems
- Prepare students for challenging industrial jobs in the engineering technology areas

The course spends about 70% time in lecture, and about 30% time in laboratory. Students are also allowed to use the PLC equipments in their convenience at other times. After the lecture, students practice PLC programming using RSLogix® from Rockwell Automation Inc. The PLC programs are then loaded to a Model 1238 PLC trainer from Future Tek, Inc. Students are able to observe the operation of the program and make necessary modifications as outlined in the course<sup>7</sup>.

### **Characteristics of Design Projects**

Students are required to complete conventional assignments of a regular lecture-based course including examinations, quizzes, and homework problems. Towards the end of the semester, students have learned the basic PLC programming instructions. It is a good time to enhance their practical problem solving abilities by working on a design project using PLCs. The purpose of the design projects is to motivate creative application of knowledge, enhance problem-solving skills, and apply real solutions to real needs<sup>8-10</sup>.

Students were expected to complete an extensive PLC design project based on the topics covered in the PLC course<sup>11-12</sup>. The project involves a proposed problem and solution with programming of ladder logic program. The final project technical report format and professional class presentation include the following contents:

- 1) A brief description and purpose of the project.
- 2) Plans, literature search, illustrations, schematic drawings and simulations
- 3) A written summary of the activities performed to complete the project
- 4) A power point based professional presentation and discussion in the class
- 5) Results, conclusions, and recommendations.

The design project started with a project proposal. The project proposal explains the objective of the project, background information, methodology to be followed and expected results. The proposals are submitted to the instructor for evaluation. The proposals are evaluated based on the contents and feasibility of the projects and necessary modifications are made. Students may choose either a team project of maximum three students or an individual based project. For a group design project, more contents and challenges are required by the instructor.

The design project is completed within a period of two weeks. A final project report is submitted at the end of the design project. An oral presentation of 10 to 15 minutes is given in the class to explain the details of the project. The written reports and oral

presentations are used to assess knowledge and skills acquired and utilized for the project.

### Examples of Design Projects

#### Example 1: Monitoring and Control of filling a tank

The PLC program simulates a process tank being filled with a fluid. The tank will start filling (via a valve) whenever the start process button is enabled and the tank is below 50% full. It will shut off when the tank is 100% full. In case the level sensor is out of calibration or not working properly, there is a high-level safety limit to prevent the tank from overflowing. If the high limit is met at a preset value of 102% full the process will shut down and a strobe light will turn on. Indicator lights are activated when the tank level reaches 50%, 75% and 100% full as shown in the diagram of the tank in Figure 1. There is a slight dead band to prevent flickering lights when tank levels vary slightly due to filling or splashing.

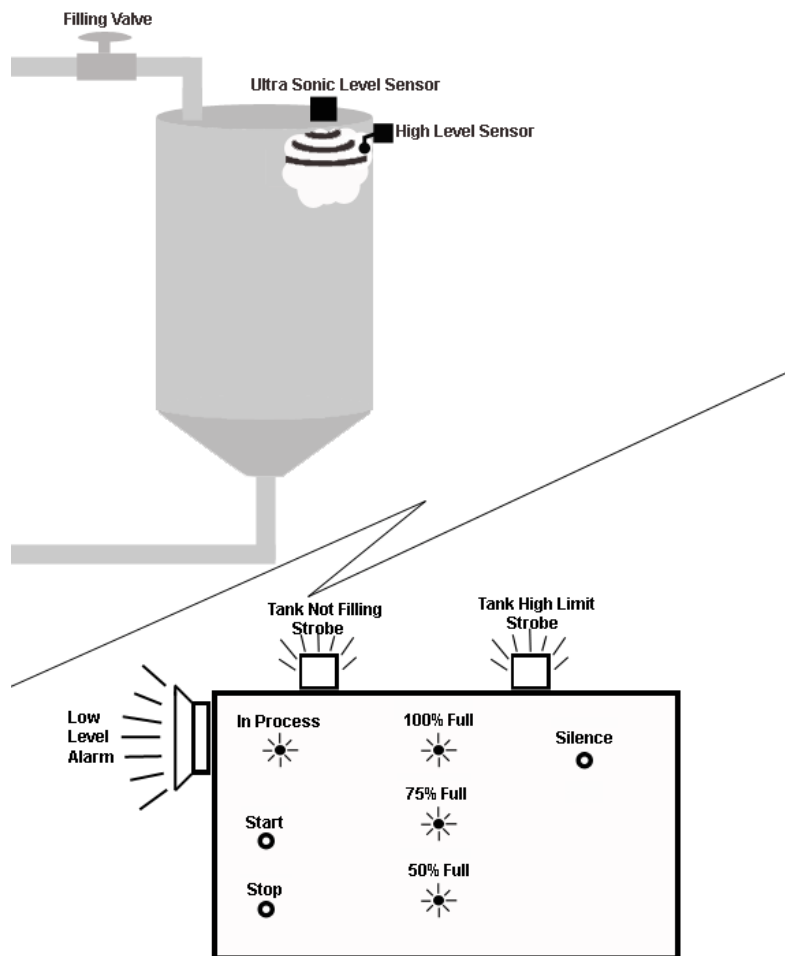

Figure 1. Diagram of the tank

If the tank for some reason does not fill up to a minimum level of 50% within 5 minutes after the valve energizes, an alarm will notify an operator. The operator will be able to silence the alarm for 5 minutes by pressing a silence button. After five minutes the alarm will trigger notifying the operator once again. The operator will be able to silence the alarm two times. If the silence button is pressed a third time, the alarm will remain on and an energized strobe light will notify anyone within the site of the tank. The silence button will be tamper proof by utilizing a one-shot rising instruction to prevent an operator from holding the button in. If the tank remains under 50% full, the only way to de-energize the alarm and strobe is to stop the process.

PLC instructions used in the system include:

- On timers (TON)
- Up Counter (CTU)
- One-shot rising instruction (OSR)
- Less than (LES), Less than or Equal to (LEQ), Greater than (GRT), Greater than or Equal to (GEQ) comparison instructions
- Divide By instruction (DIV) (for scaling analog inputs)
- Input and Output instructions (both internal and external)

A tank information board and its corresponding I/O assignment as presented by the design team are shown in Figure 2.

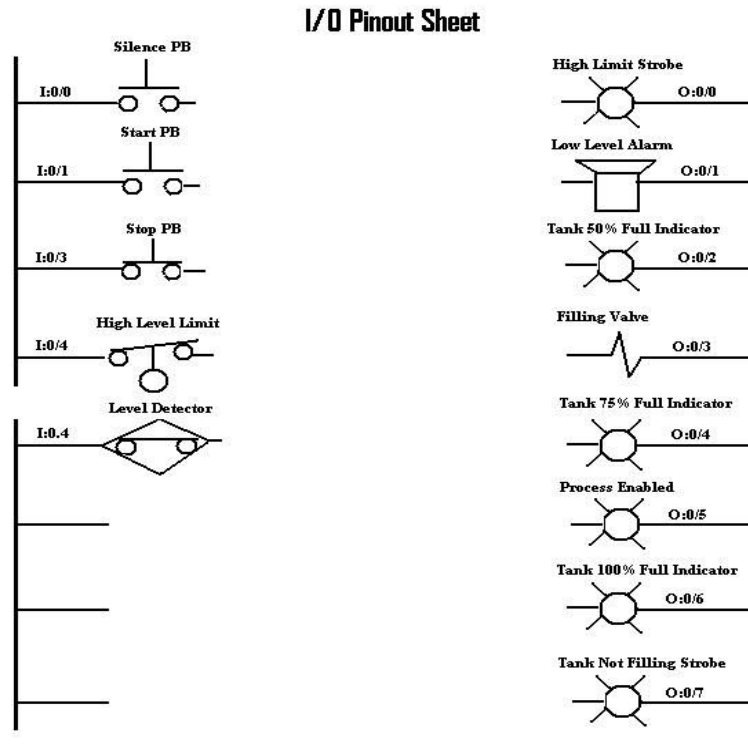

Figure 2. I/O assignment and information board

## Example 2: Hybrid boat control system

The purpose of this project is to control the operation of a gas-electric hybrid boat as shown in Figure 3. The boat was designed and built by solar electric boat team, and a PLC control was required for an efficient and reliable operation. The program runs the on/off sequence for the charging of the boat's battery packs and it mainly performs the following functions:

- Turn Motor Controller ON/OFF
- Turn Solar Panels ON/OFF
- Start and Stop Gas Generator at required time
- Reliable Operation and Simple Design

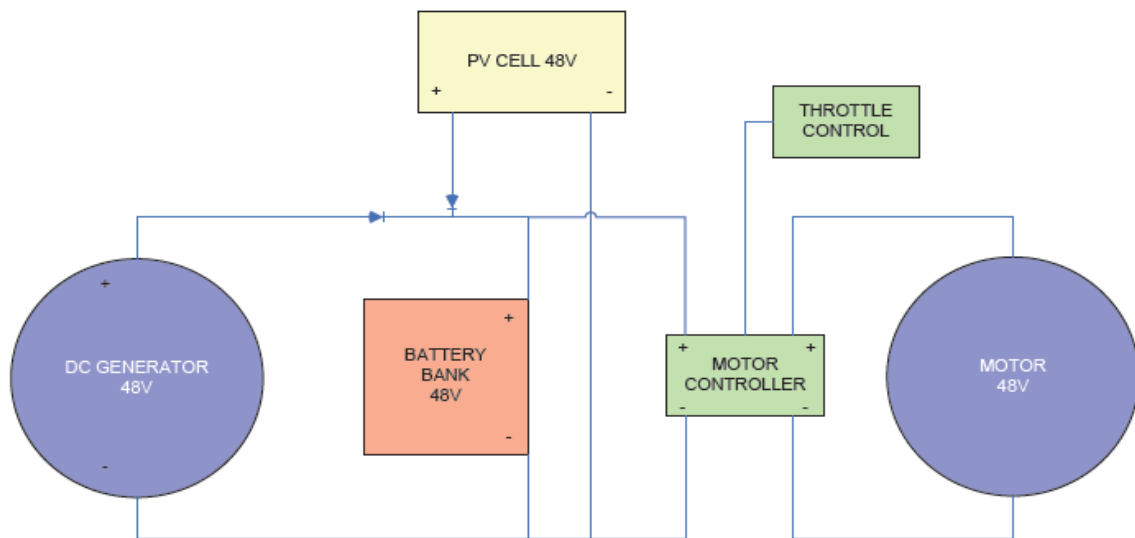

Figure 3: Functional block diagram of power and control circuit of the hybrid boat project

The I/O assignment is shown as follows. The block diagram of the system as presented by the design team is shown in Figure 4.

### Inputs

- 0 Charge / Run Sw
- 1 Throttle Limit Sw
- 2 VBatt
- 4 Generator O/R (ON)
- 5 Generator O/R (OFF)
- 6 VGen
- 3, 7 & 8 N/C
- 9 VPV

### Outputs

- 0 Key Motor Controller
- 1 Key Generator
- 2 Start Generator
- 3 Relay Generator
- 4 Relay PV
- 5 NC

Since the MicroLogix ®1000 based PLC uses digital inputs, new signal conditioning circuits that were already designed and built separately convert the voltage values below

10V DC for the input values to the PLC. In addition, comparator circuits for the voltage and current thresholds in the charging system trigger the PLC to take action.

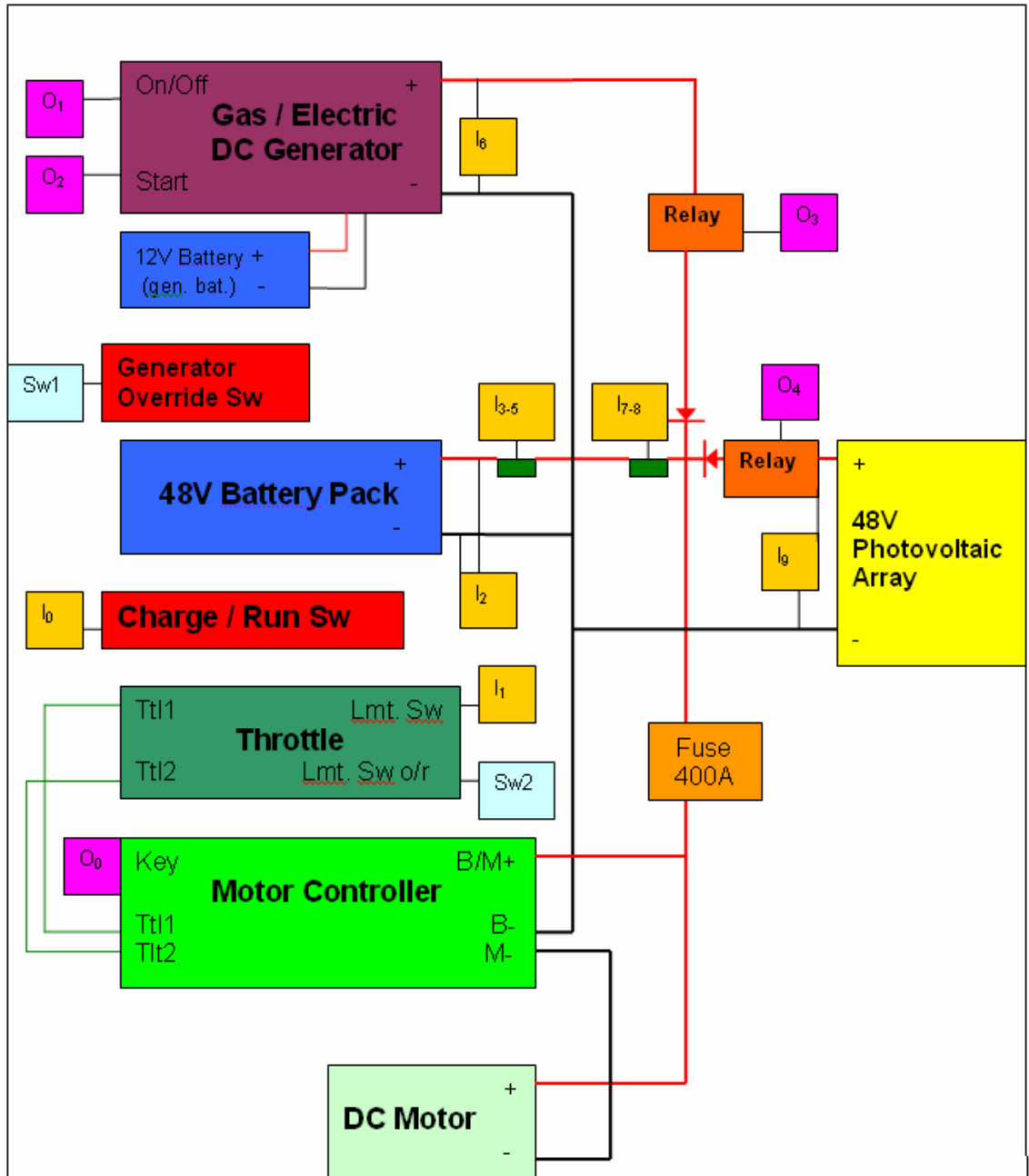

Figure 4. Block diagram of system of a hybrid boat

### Example 3: Control of a movable conveyor driven into and out of a trailer

The purpose of this project is to write a PLC program that will operate an extendible conveyor. This conveyor is used in distribution centers to load boxes onto trailers. It moves along a guide track in the floor and can be driven in and out of the trailer.

The conveyor is operated with one pushbutton for forward and the other for reverse movement. The pushbuttons must be held down the entire time when the conveyor is moving. Inputs of the system include diffuse type photoelectric sensors on the front and back of the conveyor to prevent a collision, and inductive proximity switches at the bottom of the front and back to prevent over travel condition.

The flowchart of the PLC program as presented by a student is shown in Figure 5. To extend the conveyor out, the extend pushbutton must be pressed. As long as the extend proximity switch is closed and nothing is in front of the front photo eye, the extend timer will begin timing. Once the DN bit is 1 and the reverse starter is not energized, the motor forward starter will close. At the same time the motor forward starter closes, the DN bit of the brake timer is on and the brake is energized, which releases the brake. If the operator were to release the switch, the front photoelectric switch received some reflected light, or the extend proximity switch opened, the forward starter would instantly open. This would cause the brake timer to begin counting. After 1 second, the brake DN bit changes to zero and the brake's electromagnet de-energizes to allow the brake to stop the conveyor. This timer was installed to minimize damage to the drive gearbox. If the conveyor stopped due to the photoelectric sensor seeing reflected light, the object causing the reflection must be removed, then the switch for the opposite direction must be temporarily pressed. Once this is done, travel in the original direction can continue.

Other examples of design projects include process control of production, package and sort for shipment of candy bars, car wash control, creating a mitered joint for a door frame prior to assembly, automatic garage door opener and control of traffic light for eight lanes of traffic.

### **Summary and Conclusions**

The Programmable Logic Controllers (PLC) course is a 3 credit hours course for junior/senior level Electrical Engineering Technology students. Fundamentals of PLC hardware components, programming and troubleshooting were covered in lectures first. Then students were expected to complete a PLC design project based on the topics covered in the course. The design project provides students an opportunity to apply knowledge acquired in the lecture to real engineering problems. Cases of student PLC design projects are discussed in this paper. Examples include control of filling a tank, hybrid boat control and control of a movable conveyor for a trailer. Students developed creativity, teamwork and practical problem solving skills. Communication skills of the students were enhanced from writing the final reports and giving the oral presentation in the class.



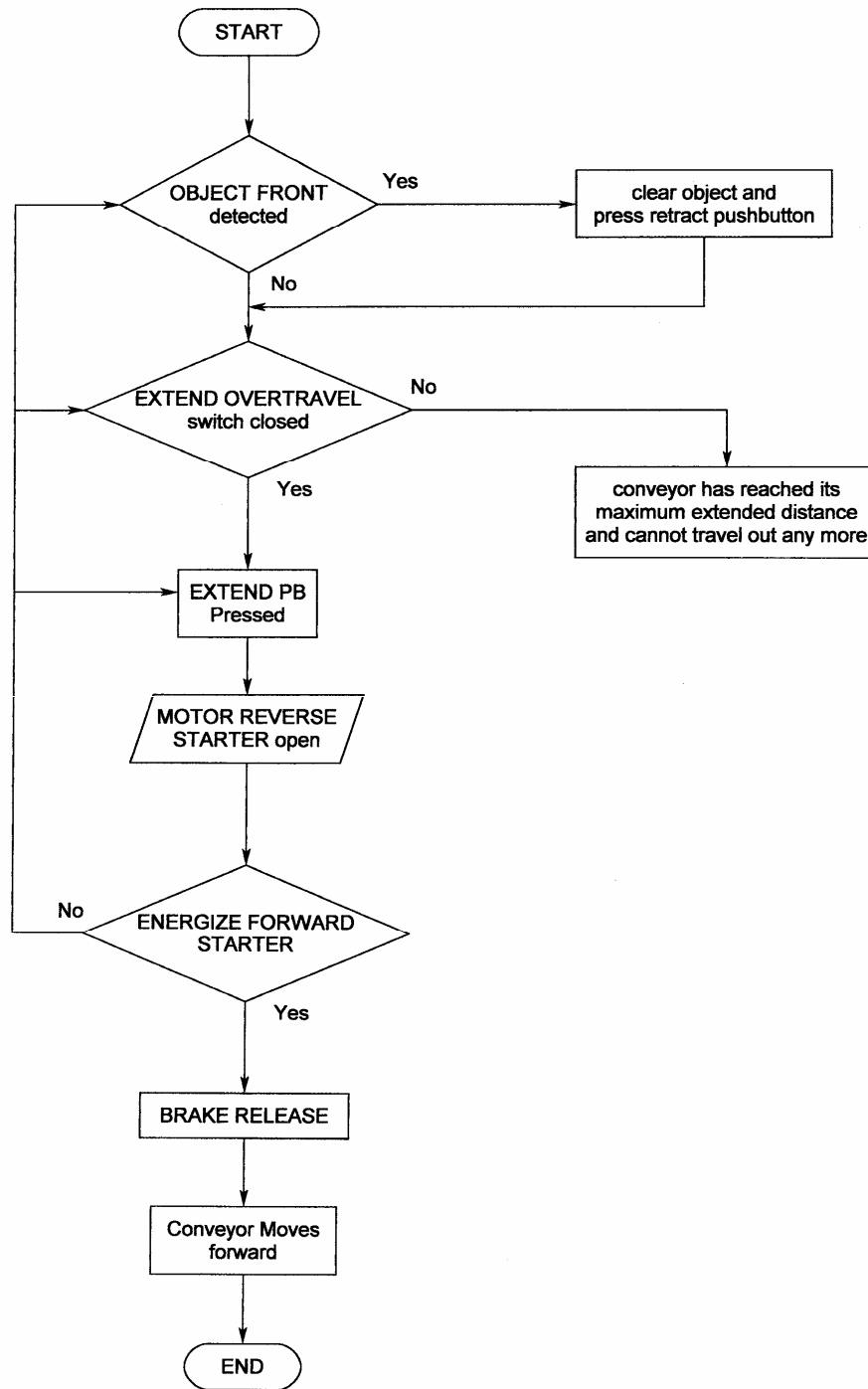

Figure 5. Flowchart of moveable conveyor control systems

## Acknowledgements

The authors would like to thank former undergraduate senior students and current engineering technologists, Michael Boomer and Benjamin Wagner for designing and building a hybrid boat and its corresponding PLC control system as part of their senior design project requirement.

## References

- [1] F. D. Petruzella, *Programmable Logic Controllers*, McGraw Hill, 2005.
- [2] C. D. Johnson, *Process Control Instrumentation Technology*, Prentice Hall, 2006.
- [3] G. Hassapis, "An interactive electronic book approach for teaching computer implementation of industrial control systems", *IEEE Transaction on Education*, Feb. 2003, Vol. 46, pp. 177 – 184.
- [4] E. W. Kamen, M. J. Gazarik, "A course in industrial controls and manufacturing for EE students and other engineering majors", *Proceeding of the 1997 American Control Conference*, June 1997, Vol. 5, pp. 3160 – 3165.
- [5] J. C. Anderson, "Design a flexible industrial controls lab module", *32<sup>nd</sup> Annual Frontiers in Education*, Nov 2002, Vol. 1, pp. 17 – 22.
- [6] J. Rehg, "PLC laboratories – the next generation", *2002 ASEE Annual Conference & Exposition*, June 2002.
- [7] J. J. Blakley, D. A. Irvine, "Teaching programmable logic controllers using multimedia-based courseware", *International Journal of Electrical Engineering Education*, Oct 2000, Vol. 37, pp. 305 – 315
- [8] J. Rehg; B. Muller, "Teaching PLCs with the IEC 61131 standard languages", *2005 ASEE Annual Conference & Exposition*, June 2000.
- [9] G. Yang, Y. Rasis, "Teaching PLC in Automation – A Case Study", *2003 ASEE Annual Conference & Exposition*, June 2003.
- [10] W. Chang, Y. Wu, et. Al, "Design and implementation of a Web-based distance PLC laboratory", *Proceeding of the 35<sup>th</sup> Southeastern Symposium on System Theory*, March 2003, pp. 326 – 329.
- [11] R. R. Rhinehart, "An integrated process control laboratory", *Proceeding of the 1994 American Control Conference*, Vol. 1, pp. 378 – 382.
- [12] C. A. Chung, "A cost-effective approach for the development of an integrated PC-PLC-robot system for industrial engineering education", *IEEE Transaction on Education*, Nov 1998, Vol. 41, pp. 306 – 310.