

## **TEACHING INTRODUCTORY CIRCUIT ANALYSIS USING A SIGNAL PROCESSING APPROACH**

**James Bryant**

**Professor (Electronic Engineering Technology)**

**DeVry University; Columbus, OH 43209**

### **Abstract**

This paper suggests that a traditionally modeled circuit analysis course may no longer provide the optimal preparation for the more advanced courses in a contemporary Electrical or Electronic Engineering curriculum. Specifically most contemporary Electrical Engineering and Electronic Engineering curricula emphasize courses that either directly or indirectly involve electronic signal processing in some fashion. It therefore seems appropriate to expect an introductory circuit analysis course to adopt where possible, a signal processing perspective.

The signal processing perspective requires a teaching orientation that views the electronic circuit as a functional entity designed to receive an input signal and to produce a desired output signal. The circuit transfer function is introduced as the mathematical expression that describes the relationship between the input and output signal. An introductory circuit analysis course emphasizing a signal processing perspective should not be confused with an advanced analog signal processing course that requires advanced mathematical background such as the Laplace Transform. However the introductory circuit analysis course can and should emphasize a signal processing perspective where it is possible and appropriate.

This paper presents a strategy for teaching introductory circuit analysis from a signal processing perspective. The strategy incorporates an appropriate orientation and sequencing of introductory circuit analysis material as well as the use of computer simulation and mathematics based software to enhance and facilitate the signal processing emphasis.

### **Introduction**

Introductory circuit analysis has long been a standard required first course in Electrical and Electronic Engineering curricula. The course traditionally involves calculating current, voltage and power for a variety of DC and AC circuit configurations. AC analysis typically involves circuits that contain resistors, capacitors, and inductors under sinusoidal excitation.

*“Proceedings of the 2005 American Society for Engineering Education Annual Conference & Exposition  
Copyright © 2005, American Society for Engineering Education”*

Introductory circuit analysis courses and the texts that support these courses have not changed dramatically over the years while during this same time period the nature of electronic circuits and systems has been reborn many times over. The one constant throughout the evolution of electronic circuits and systems is that Electrical and Electronic Engineering remains in large part the science of creating, processing, and transmitting electronic signals. An introductory circuit analysis course that emphasizes signal processing concepts provides the student with a more relevant introduction to the nature and function of electronic circuits.

### **Defining a Signal Processing Approach to Teaching Circuit Analysis**

The signal processing approach to teaching circuit analysis views the electronic circuit as an entity designed to receive an input signal and to produce a desired output signal as illustrated in Figure 1.

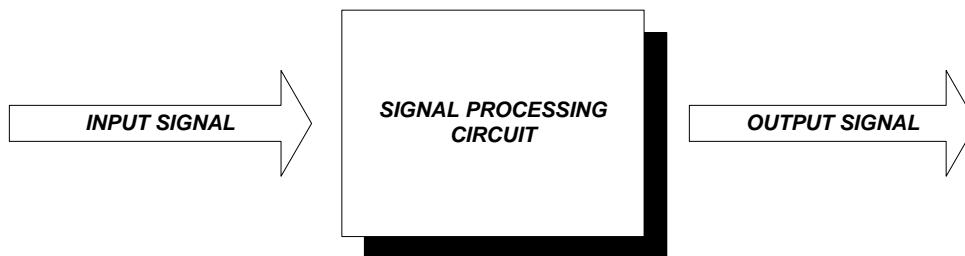

*Figure 1 (A Signal Processing Perspective)*

A circuit analysis course emphasizing signal processing is based upon traditional applications of Ohm's law and Kirchhoff's laws. In addition, however, the signal processing orientation of the course emphasizes the purpose and applications of circuit analysis rather than emphasizing only the procedures of circuit analysis.

Beginning Electrical and Electronic Engineering students can immediately relate to the importance of electronic signals in nearly every facet of life in a modern society. From sophisticated video games to delicate nano-surgery, from cellular phones to global communications, electronic signals in large part shape the way that we live. A course that presents circuit analysis with an emphasis on signals and signal processing can be expected to be viewed by students as more practical, more useful, and more relevant than a more traditional approach to teaching circuit analysis.

### **Contrasting a Traditional Approach and a Signal Processing Approach to Teaching Circuit Analysis**

Traditional circuit analysis courses help the student to master the methods of circuit analysis, but often fail to connect the subject matter to a well-defined purpose.

*"Proceedings of the 2005 American Society for Engineering Education Annual Conference & Exposition Copyright © 2005, American Society for Engineering Education"*

A variety of circuits are typically solved to determine such quantities as the value of a voltage at a specified node or the current through a particular component or branch within the circuit. While such analysis skills are inherently useful they should not be viewed as an end in themselves.

Traditional courses that focus entirely upon the methods and procedures of circuit analysis often fail to convey to the student the practical importance of circuit analysis to the Electrical or Electronic Engineer. A typical justification for a traditional course in circuit analysis is that the skills learned will be utilized in future courses. Most students, however, are more strongly attracted to courses that have a clear purpose and identity of their own rather than courses whose applications, purpose, and value can only be realized indirectly in future courses.

A circuit analysis course emphasizing signal processing possesses its own merits and identity as a stand alone course. The relationship between a circuit analysis course emphasizing signal processing and upper level courses now becomes synergistic rather than dependent.

An introductory circuit analysis course that emphasizes signal processing relates to upper level courses in a contemporary curriculum in a direct and meaningful way as illustrated in Figure 2.

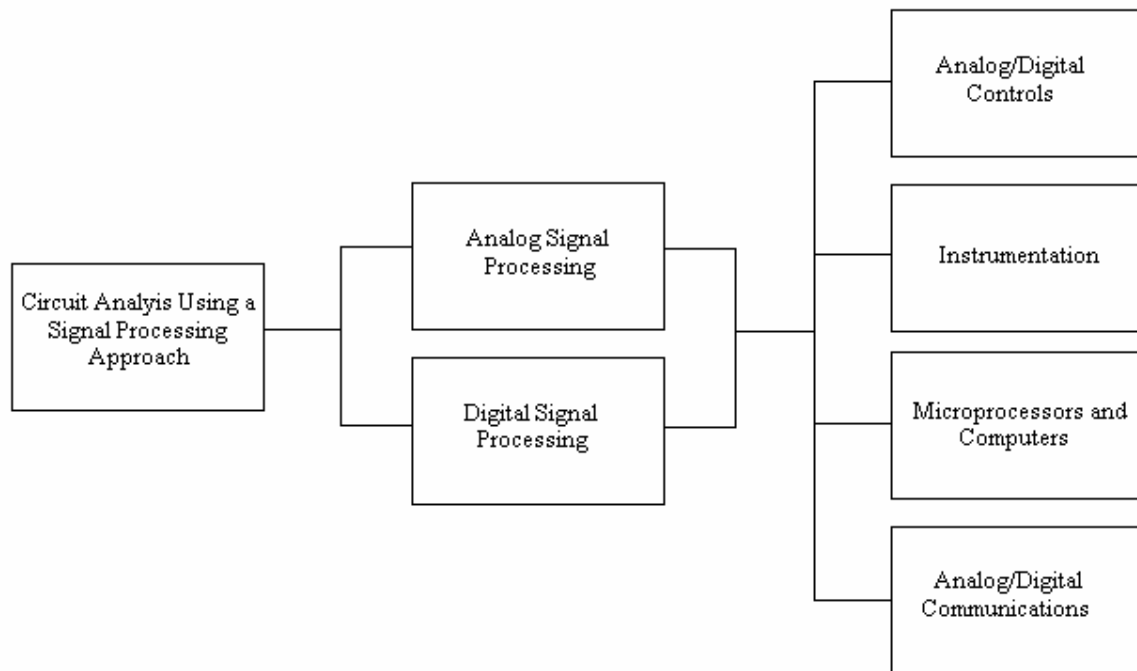

**Figure 2 ( Signal Processing Linked to Upper Level Courses)**

*“Proceedings of the 2005 American Society for Engineering Education Annual Conference & Exposition  
Copyright © 2005, American Society for Engineering Education”*

While other important courses exist in a contemporary Electrical or Electronic Engineering curriculum, the link between the core technical courses in the curriculum is electronic signal processing. Most contemporary Electrical and Electronic Engineering curricula contain a course dedicated to analog and digital signal processing as indicated in Figure 2. These signal processing courses provide substantial foundation for the remaining courses in the upper levels of the curriculum.

The upper level courses identified in Figure 2 as Instrumentation, Analog/Digital Controls, Analog/Digital Communications, and Microprocessors and Computers are in large part applications of electronic signal processing. It can be reasonably stated that signal processing is the common link between nearly all of the major technical courses in a contemporary Electrical or Electronic Engineering curriculum.

### **Integrating Traditional Circuit Analysis and Circuit Analysis Emphasizing Signal Processing Concepts**

An example of integrating traditional circuit analysis and a signal processing approach can be illustrated in the use of the voltage divider rule. A traditional circuit analysis course typically demonstrates how the voltage divider rule can be used to determine the voltage at any point in a series configuration as illustrated in Figure 3.

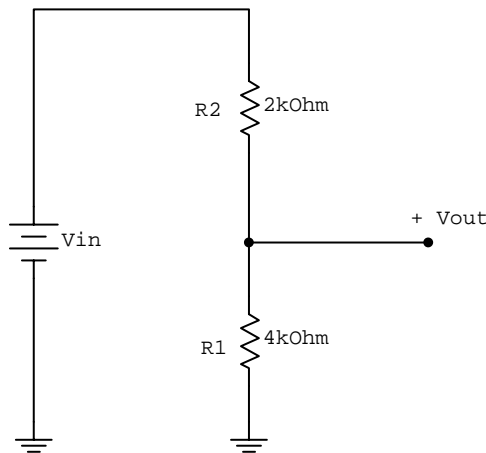

***Figure 3 (A DC Circuit Emphasizing a Signal Processing Perspective)***

The voltage divider rule in a circuit analysis course emphasizing signal processing will be used to determine the transfer function of the circuit. The concept of the transfer function relates directly to signal processing but it is derived using traditional analysis techniques. Signal processing concepts such as the transfer function, voltage or current gain, and decibel gain can be demonstrated in either DC or AC circuit applications.

*“Proceedings of the 2005 American Society for Engineering Education Annual Conference & Exposition  
Copyright © 2005, American Society for Engineering Education”*

When emphasizing a signal processing perspective the series DC circuit shown in Figure 3 is described as a *voltage attenuator*. The function of the circuit is to reduce the amplitude of the input signal voltage to a specified value. The transfer function of the circuit is determined using the voltage divider rule to be:

$$\text{T.F.} = \frac{V_{\text{out}}}{V_{\text{in}}} = \frac{R_1}{R_1 + R_2} \quad (1)$$

Where T.F. is the transfer function of the circuit,  $V_{\text{out}}$  is the output signal and  $V_{\text{in}}$  is the input signal.

The *voltage gain* of the circuit is determined as the magnitude of the transfer function in Equation (1) as:

$$\text{AV} = \frac{4\text{k}\Omega}{4\text{k}\Omega + 2\text{k}\Omega} = 0.667 \quad (2)$$

where AV is the voltage gain of the circuit.

The *decibel voltage gain* may be calculated as:

$$\text{AV(dB)} = 20\log(\text{AV}) = 20\log(0.667) = -3.517\text{dB} \quad (3)$$

Where AV(dB) is the voltage gain in units of decibels

The example above illustrates how a signal processing emphasis can be accomplished through the analysis of a basic series DC circuit.

A second example of emphasizing a signal processing approach to teaching introductory circuit analysis is illustrated in the RC Low-pass filter circuit shown in Figure 4.

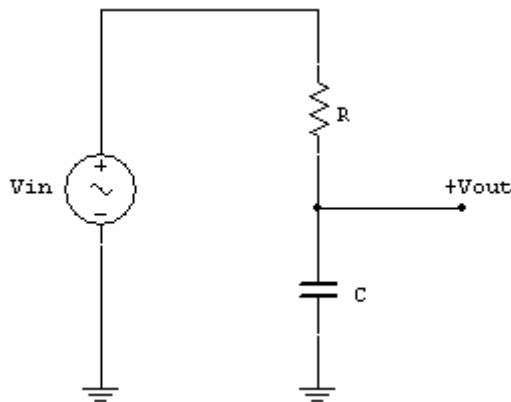

**Figure 4 (An RC Low-pass Filter Emphasizing a Signal Processing Perspective)**

From a signal processing perspective, the filter shown in Figure 4 is described as a circuit designed to alter the frequency content of a complex input signal. This description is consistent with the concept that the circuit is designed to process an input signal in order to produce a desired output signal.

The analysis follows a strategy similar to that used in the preceding DC example. The transfer function is determined in the phasor domain using the voltage divider rule as:

$$\mathbf{T.F} = \frac{\mathbf{X}_c}{\mathbf{R} + \mathbf{X}_c} \quad (4)$$

where  $\mathbf{X}_c$  is capacitive reactance in the phasor domain and R is resistance in the phasor domain.

The transfer function may then be evaluated at any desired frequency. The magnitude of the transfer function is the voltage gain of the filter and the angle of the transfer function represents the phase difference between the input and output signal.

Both of the examples above demonstrate how a signal processing perspective can be emphasized and incorporated with traditional DC/AC circuit analysis principles.

### **Beyond The RLC Circuit**

Traditional introductory circuit analysis courses typically consider circuits comprised of resistors, capacitors, and inductors.

An introductory circuit analysis course designed to emphasize signal processing applications should include a sampling of basic circuits comprised of non-linear circuit components as well. By analyzing and designing diode limiters, transistor bias circuits, and fundamental operational amplifier circuits, the student gains a broader experience in the application of circuit analysis laws.

It is neither necessary nor beneficial to consider a circuit analysis course emphasizing a signal processing approach to be comparable to a course dedicated to the study of electronic devices. Non-linear devices (diode, transistor, and operational amplifier) in the context of a circuit analysis course need only be presented in a “black box” setting. Only the characteristics and parameters necessary to successfully analyze a circuit containing the device need be discussed. The course should remain focused on circuit analysis.

The inverting operational amplifier circuit, for example, can be analyzed to determine the closed loop gain once the device characteristics of infinite input impedance, zero output impedance and the concept of virtual ground have been introduced.

*“Proceedings of the 2005 American Society for Engineering Education Annual Conference & Exposition  
Copyright © 2005, American Society for Engineering Education”*

The more subtle operational amplifier parameters such as slew rate and gain-bandwidth-product can and should be deferred to an appropriate electronics devices course.

While a circuit analysis course emphasizing a signal processing approach should not compete with an electronics devices course; the course is complementary of a dedicated devices course. The student in a circuit analysis course emphasizing signal processing, for example, can learn to calculate the DC operating point for a transistor bias network as an exercise in circuit analysis. The devices course can then focus on the finer points of bias networks such as bias stability, load-line and frequency analysis. Covering such topics as fundamental diode, transistor, and operational amplifier circuits in an introductory circuit analysis course is particularly justified given that the curriculum space allocated to circuit analysis and electronic devices has been reduced in many contemporary Electrical and Electronic Engineering programs.

### **Organization of a Circuit Analysis Course Emphasizing a Signal Processing Approach**

Organizing and sequencing the content of a circuit analysis course that emphasizes a signal processing approach need not be radically different from the more traditional circuit analysis course. Although the essence of course content is similar for either approach, teaching the course material emphasizing signal processing concepts can produce more useful learning outcomes. The student is no longer analyzing circuits solely to practice the application of circuit laws; rather the student learns how to apply circuit analysis to determine a transfer function, circuit gain, characteristics of an output signal, or other signal processing related quantity.

The sample organizational diagram shown in Figure 5 illustrates how a signal processing emphasis can be integrated into an introductory circuit analysis course. A brief description of each organizational block is given to highlight how and where signal processing can be emphasized in an introductory circuit analysis course. Individual instructor creativity and experience can greatly enhance the given suggestions.

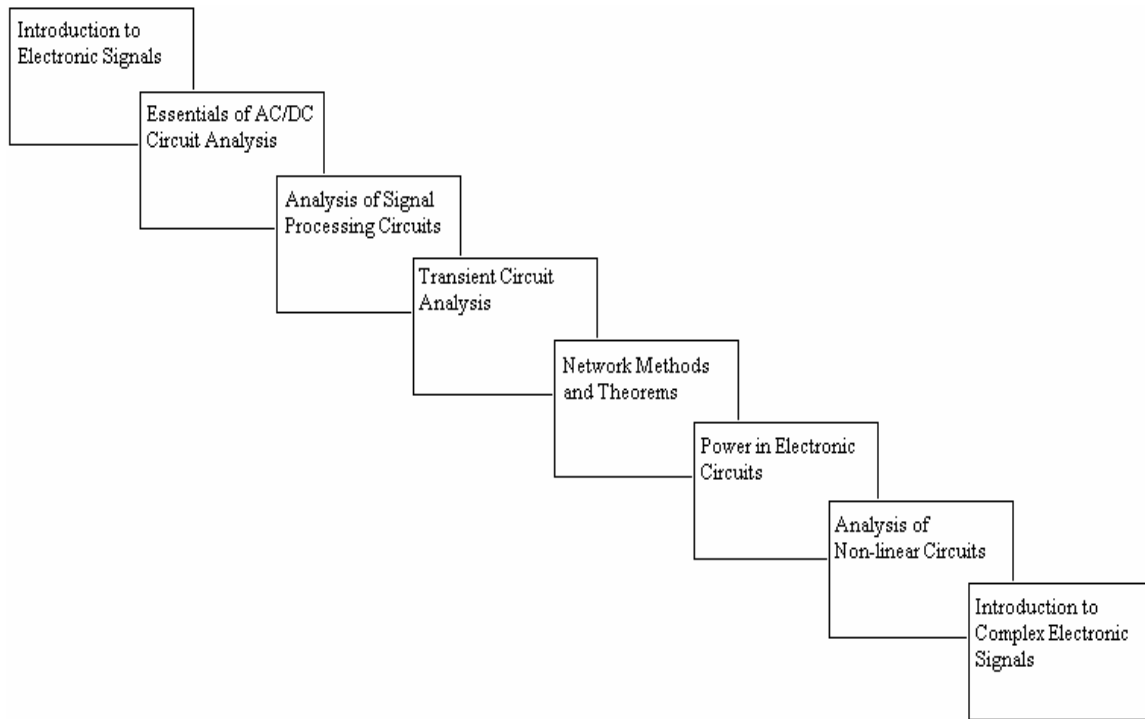

**Figure 5 (Organization of an Introductory Circuit Analysis Course Emphasizing Signal Processing)**

### **Block 1: An Introduction to Electronic Signals**

A course in introductory circuit analysis emphasizing signal processing begins with an introduction to the diverse and prolific utilization of electronic signals in a modern society. Students can be reminded that video games, cellular telephony, digital audio, digital photography, and satellite communications, are but a few examples of how electronic signals impact our daily lives.

A more detailed introduction to electronic signals leads to a discussion of the nature of current and voltage. A general discussion of transducers may be included as the devices that convert physical quantities into electronic signals. It is important to establish a signal processing orientation by indicating that the overriding purpose of circuit analysis is to analyze and design electronic signal processing circuits and systems.



## **Block 2: Essentials of DC/AC Circuit Analysis**

The course continues with a traditional introduction of Ohm's law and Kirchhoff's laws. The laws are demonstrated in the analysis of both DC and AC circuits. The student should become proficient in the use of Ohm's law, Kirchhoff's laws, and the voltage and current divider rules for both DC and AC circuits.

It should be noted that the analysis skills developed in Block 2 will be reinforced throughout the remainder of the course. Block 2 should therefore focus on DC/AC circuit analysis essentials and avoid overly complex circuits.

## **Block 3: Analysis of Signal Processing Circuits**

The fundamental circuit analysis principles previously introduced are now applied to linear circuits that emphasize a signal processing orientation. The attenuator (two series resistors) is an excellent beginning circuit to introduce the concepts of the transfer function, gain, decibel gain, and phase relationship between an input and output signal.

The analysis principles can be further extended to the family of low-pass, high-pass, and band-pass filters that can be created using resistors, capacitors, and inductors. The signal processing approach to analyzing filters is to first determine the transfer function for the filter, and then evaluate the transfer function at any desired frequency to determine gain and phase. This approach establishes a pattern that will be reinforced in upper level signal processing courses as well as controls and communications courses that employ a similar approach using the Laplace transform or Z-transform.

A brief non-mathematical introduction to the nature of complex electronic signals may be considered at this point. Specifically a periodic complex signal can be qualitatively described as a summation of sinusoidal waveforms of varying frequency, amplitude, and phase. The electronic filter circuit can then be more clearly defined as a circuit whose purpose is to alter the frequency content of a complex input signal. The concept of the complex electronic signal and the function of electronic filter circuits can be merged through the analysis or design of filter applications such as a three-way cross-over network. The cross-over network is designed to direct the low, mid-range, and high frequency components of a complex audio signal to a speaker designed for optimum response to a particular range of frequencies.

## **Block 4: Transient Circuit Analysis**

Transient circuit analysis focuses on the response of RC and RL circuits to DC excitation, or more appropriately, switched DC excitation.

The square wave may be introduced as a logical extension of a switched DC wave form which leads to the analysis and applications of the integrator and differentiator circuits.

*"Proceedings of the 2005 American Society for Engineering Education Annual Conference & Exposition  
Copyright © 2005, American Society for Engineering Education"*

Again the important perspective of the electronic circuit as signal processing entity is emphasized.

### **Block 5: Network Methods and Theorems**

Network methods of analysis and network theorems can be selected by individual instructor preference taking into account time allocation for this subject matter.

Full coverage of both Mesh and Nodal analysis for example, is time consuming and a prudent decision may be to cover only one of the two methods. Similarly, it may be necessary to choose between Thevenin's theorem and Norton's theorem.

From a signal processing perspective the three most relevant topics in this section are the superposition theorem, the maximum power transfer theorem, and Thevenin's theorem. These theorems will be utilized later in the course regarding important signal processing applications such as delivering maximum power transfer from a signal source to a load.

### **Block 6: Power Considerations in Electronic Circuits**

Power considerations in a circuit analysis course emphasizing signal processing should stress such topics as maximum power transfer and impedance matching and calculating power requirements for circuit components.

A circuit analysis course emphasizing signal processing should abbreviate the coverage of the more traditional power topics such as real, reactive, apparent power, and multi-phase power systems. While a thorough discussion of these topics is essential to a power engineering curriculum, they are not essential to a circuit analysis course that emphasizes signal processing applications. The electronics engineer is much more likely to be concerned with signal power transfer than with the power factor of an electronic circuit.

### **Block 7: Analysis of Non-linear Circuits**

Analysis of a variety of fundamental signal processing circuits that contain non-linear devices provides the student with a more extensive range of circuit analysis applications than the traditional circuit analysis course. The important objective is to expand the coverage beyond the RLC circuit while maintaining a circuit analysis focus. In this context, determining the DC operating point for a transistor bias network or the closed loop gain of an inverting amplifier is solely an exercise in circuit analysis. The details of transistor biasing and amplifier analysis are appropriately deferred to a dedicated electronic devices course.

## **Block 8: An Introduction to Complex Signals**

An introduction to non-sinusoidal signals based upon the Fourier series can include common periodic signals such as the rectified sine wave, the square wave, and sawtooth wave.

The purpose and scope of material involving non-sinusoidal signals in an introductory circuit analysis course should not approach the detail expected in a course dedicated to analog signal processing using the Laplace transform. The important emphasis from a signal processing circuit analysis perspective is that electronic signals that contain significant information are more complex than purely sinusoidal signals.

While Fourier series is typically considered to be an advanced specialty topic in mathematics, the rigor of the mathematics can be greatly simplified for the pre-calculus student through the use of computer mathematics-based software.

### **Teaching Tools for a Circuit Analysis Course using a Signal Processing Approach**

The engineering calculator is an indispensable tool when teaching circuit analysis emphasizing signal processing. The engineering calculator minimizes the time required to make calculations, especially involving complex numbers (phasors), and permits more time to be allocated to thoughtful problem-solving. The engineering calculator should not be used exclusively, but should be integrated with appropriate manual mathematical calculations and derivations.

Circuit simulation software can be utilized throughout an introductory circuit analysis course to verify the accuracy of theoretical calculations, and to provide a visual component to the learning experience.

Mathematics-based software can be effectively utilized not only to solve challenging equations but also to create waveform plots that often enhance learning.

The objective regarding the selection and use of the engineering calculator and computer-assisted analysis and design is to create an analytical environment representative of a practical contemporary engineering work station.

### **Summary and Conclusions**

An introductory circuit analysis course is a critical first course for the student of Electrical or Electronic Engineering. An important measure of the success of an entry level course is its ability to interest and motivate students to continue to pursue the study of electrical or electronic engineering.

Student course evaluations from the Introductory Circuit Analysis course that I teach indicate that a signal processing emphasis increases student satisfaction with the course. Furthermore discussions with colleagues who either teach Introductory Circuit Analysis or related courses support the signal processing emphasis.

The author hopes that this paper will encourage other faculty to reexamine the content and effectiveness of their Introductory Circuit Analysis courses. While agreement on all points in this paper is not expected, justifying the content of an Introductory Circuit Analysis course from a purely traditional bias fails to explore the innovative possibilities of a contemporary circuit analysis course.

### **Bibliography**

- [1] Artice Davis, Some Fundamental Topics in Introductory Circuit Analysis: A Critique. IEEE Transactions on Education, Vol. 43, No 3, August 2000
- [2] L.R. Carley, P. Khosla, R. Unetich, Teaching Introduction to Electrical and Computer Engineering in Context. Proceedings of the IEEE, 2000.
- [3] M.A. Yoder, J.H McClellan, R.W. Schafer, Crystal Radios or DSP First. Frontiers in Education Conference, 1998.
- [4] D.H Johnson, J.D Wise, A Different First Course in Electrical Engineering. Proceedings of the IEEE International Conference on Acoustics, Speech, and Signal Processing, 1998.
- [5] S.L Wood, A Concept Oriented Freshman Introductory Course Utilizing Multimedia Presentations and Group Laboratory Experience. Frontiers in Education Conference, 1998.
- [6] J.A. Orr, W. Eggimann, D. Nicoletti, D. Cyganski, An Electrical Engineering Curriculum Beginning in the First Year. Frontiers in Education Conference, 1994.

### **Biographical Information**

**JAMES BRYANT** received the B.S. degree in electrical engineering from the University of Dayton, Dayton, Oh, in 1965, the MBA degree from the University of Dayton in 1985, and the degree of M.S. in Engineering from Wright State University in 1996. He is currently a professor and department chair of the electronics engineering technology program at the DeVry University at Columbus Oh.