

TELLEGEN'S THEOREM APPLIED TO MECHANICAL, FLUID AND THERMAL SYSTEMS

Ravi P. Ramachandran¹ and V. Ramachandran²

1. Department of Electrical and Computer Engineering, Rowan University, Glassboro, New Jersey 08028
2. Department of Electrical and Computer Engineering, Concordia University, Montreal, Canada H3G 1M8

Introduction

Tellegen's theorem [1][2] has been applied to several electrical systems that are linear or nonlinear, reciprocal or nonreciprocal, time-variant or time-invariant, and so forth. Tellegen's theorem states that the total power delivered to all the components of an electrical network is zero [1][2]. This result has profound consequences in that the sum of the products of voltages and currents should be zero. If the voltage and current variables of a circuit are interchanged, we get an equivalent circuit with the same total delivered power. The two circuits are equivalent in terms of Kirchoff's Laws and topological equivalence [1][2]. However, there is no dependence on the components of the circuit. For example, one may be a nonlinear resistive circuit and the other may be a linear circuit. The significant implication of Tellegen's theorem comes from the fact that two or more circuits with the same power constraints can be configured with no restrictions on linearity, time-invariance and method of analysis. The practical implication comes in the design process where students can examine several equivalent networks and use for example, the simpler one in part of a design. So far, the discussion has centered about analog electrical networks only. Tellegen's theorem has been extended to discrete systems used in discrete signal processing [3]. This provides the derivation of different structures and a desirable one is chosen to suit the other properties required for a design. In this paper, we show that Tellegen's theorem can be extended to other types of systems. We consider mechanical, fluid and thermal systems.

Across and Through Variables

It is known that these four systems (electrical, mechanical, fluid and thermal) can be given a unified treatment by the use of across-variables $\{av(t)\}$ and through-variables $\{tv(t)\}$ [4].

It is to be noted that for each system these variables are different and Table 1 gives these variables, along with their units.

System	Across-variable $av(t)$	Through-variable $tv(t)$
Electrical	Voltage (volts) $v(t)$	Current (amperes) $i(t)$
Mechanical (Translational)	Velocity $v(t)$ (meters/second)	Force $f(t)$ (Newtons)
Mechanical (Rotational)	Angular Velocity $\omega(t)$ (radians/second)	Torque $T(t)$ (Newtons)(meters)
Fluid	Pressure difference $p(t)$ (Pascals or Newtons/meter ²)	Flow rate $q(t)$ (meter) ³ /second
Thermal	Degree Difference θ °C (°Celsius)	Heat Flow $\phi(t)$ (watts)

Table 1 Across and Through Variables for Different Types of Systems

In each system, there will be mathematical relationships between $av(t)$ and $tv(t)$ depending on the property or physical element. These are:

$$av(t) = k_1 tv(t) \quad (1a)$$

$$av(t) = k_2 \frac{d[tv(t)]}{dt} \quad (1b)$$

$$av(t) = k_3 \int tv(t) dt \quad (1c)$$

The relationship (1a) corresponds to that of a resistor or equivalent; the relationship (1b) corresponds to that of an inductor or equivalent; and the relationship (1c) corresponds to that of a capacitor or equivalent. These relationships are not required in the statement of the extended Tellegen's theorem that we propose. However, they are required in the analysis. The analysis may be carried out either in the time-domain or in the Laplace transform domain. The Laplace transform domain equations corresponding to Eqs. (1a), (1b) and (1c) are given below:

$$Av(s) = k_1 \cdot Tv(s) \quad (2a)$$

$$Av(s) = (sk_2) \cdot Tv(s) \quad (2b)$$

$$Av(s) = \left(\frac{k_3}{s} \right) Tv(s) \quad (2c)$$

These equations are given assuming that the initial conditions are zero. If initial conditions are present, they are added as suitable sources.

Table 2 gives the equations in the Laplace-transform domain (and hence the impedances) in the above-mentioned systems corresponding to Eqs. (2a), (2b) and (2c).

	Resistance {Eq.(2a)}	Inductance {Eq.(2b)}	Capacitance {Eq.(2c)}
Electrical	$V(s) = R I(s)$	$V(s) = (sL) I(s)$	$V(s) = \frac{I(s)}{sC}$
Mechanical (Translational)	$F(s) = b V(s)$ (b = damper constant)	$F(s) = \frac{k}{s} V(s)$ (k = spring constant)	$F(s) = (sm) V(s)$ (m = mass in kg)
Mechanical (Rotational)	$T(s) = B \omega(s)$ (B = damper constant)	$T(s) = \frac{K}{s} \omega(s)$ (K = spring constant)	$T(s) = (sJ) \omega(s)$ (J = moment of inertia in $(\text{kg} \cdot \text{meter}^2)$)
Fluid	$P(s) = R_f Q(s)$	$P(s) = (sL_f) Q(s)$	$P(s) = \left(\frac{1}{sC_f} \right) Q(s)$
Thermal	$\varphi(s) = \frac{1}{R_{\text{Thermal}}} \theta(s)$	(Does not exist)	$\varphi(s) = (sC_f) \theta(s)$

Table 2 Laplace Transform Relationships Between Across and Through Variables for Different Types of Systems

From Table 2, it is noted that a damper is the mechanical equivalent of a resistor and the spring is the mechanical equivalent of an inductor. The mechanical equivalent of a capacitor is either mass or moment of inertia. For fluid systems, the notions of resistance, inductance and capacitance exist. A tank is the physical realization of a capacitor. For thermal systems, only the concepts of resistance and capacitance exist.

Application of Tellegen's Theorem To All Four Systems

Let N_a be the equivalent electrical network of a system and let N_b be another electrical equivalent network of the same system in that both N_a and N_b have the same topology. The extended Tellegen's theorem that we propose has four parts and they are given below. The relationships are written in the Laplace-transform domain. However, similar relationships can be written in the time-domain also.

Relationship (1):

$$\sum_{k=1}^B A_{v_{ak}}(s) \cdot T_{v_{ak}}(s) = 0 \quad (3a)$$

Relationship (2):

*"Proceedings of the 2001 American Society for Engineering Education Annual Conference & Exposition
Copyright © 2001, American Society for Engineering Education"*

$$\sum_{k=1}^B A v_{bk}(s) \cdot T v_{bk}(s) = 0 \quad (3b)$$

For both equations (3a) and (3b), B is the number of branches in the network graph and is the same in both the systems. The subscript ak refers to the kth branch of Network N_a. Similarly, the subscript bk refers to the kth branch in Network N_b. The summation is taken over all the branches. Hence, in Network N_a, the branches are numbered as a1, a2, and so on. Similarly, in Network N_b, the branches are numbered as b1, b2, and so on. The relationships in equations (3a) and (3b) can readily be interpreted as the consequence of the Law of Conservation of Energy in a system. For example, in an electrical system, the sum of the products of voltage and current (which is the power) in each branch is equal to zero.

Relationship (3):

$$\sum_{k=1}^B A v_{ak}(s) \cdot T v_{bk}(s) = 0 \quad (3c)$$

Relationship (4):

$$\sum_{k=1}^B A v_{bk}(s) \cdot T v_{ak}(s) = 0 \quad (3d)$$

Equations (3c) and/or (3d) can be interpreted as the sum of the products of the av's (or tv's) in Network N_a and the tv's (or av's) in Network N_b will always be equal to zero. The following examples illustrate the above concept.

Example 1 – Mechanical System

Figure 1(a) shows a mechanical system (called N_a) and Figure 1(b) shows its equivalent circuit in the Laplace-transform domain.

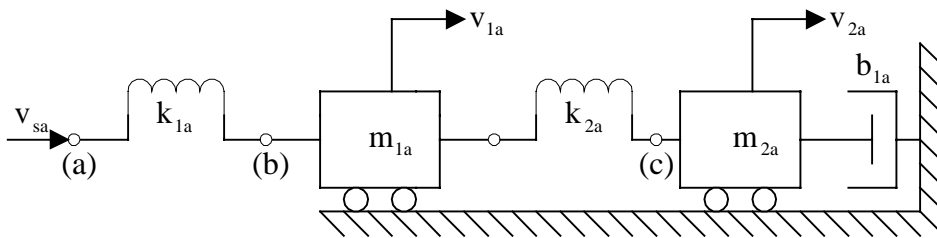

Figure 1(a) A mechanical system designated as N_a

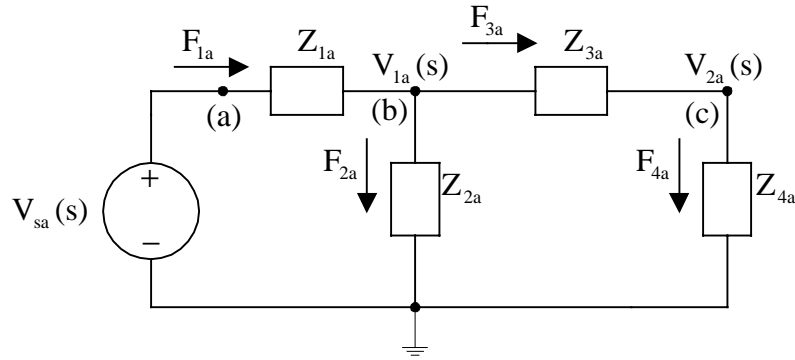

Figure 1(b) The equivalent circuit of Figure 1(a) in the Laplace transform domain

The impedances are given by

$$Z_{1a} = \frac{s}{k_{1a}}, Z_{2a} = \frac{1}{sm_{1a}}, Z_{3a} = \frac{s}{k_{2a}} \text{ and } Z_{4a} = \frac{1}{b_{1a} + sm_{2a}} \quad (4)$$

Analysis yields

$$F_{1a}(s) = \frac{(Z_{2a} + Z_{3a} + Z_{4a})V_{sa}(s)}{Z_{1a}(Z_{2a} + Z_{3a} + Z_{4a}) + Z_{2a}(Z_{3a} + Z_{4a})} \quad (5a)$$

$$F_{2a}(s) = \frac{(Z_{3a} + Z_{4a})V_{sa}(s)}{Z_{1a}(Z_{2a} + Z_{3a} + Z_{4a}) + Z_{2a}(Z_{3a} + Z_{4a})} \quad (5b)$$

$$F_{3a}(s) = F_{4a}(s) = \frac{(Z_{4a})V_{sa}(s)}{Z_{1a}(Z_{2a} + Z_{3a} + Z_{4a}) + Z_{2a}(Z_{3a} + Z_{4a})} \quad (5c)$$

$$V_{1a}(s) = F_{2a}(s) Z_{2a} \quad (5d)$$

$$V_{2a}(s) = F_{4a}(s) Z_{4a} \quad (5e)$$

We shall now consider another mechanical system (called N_b) shown in Figure 2(a) and its Laplace-transform domain equivalent circuit in Figure 2(b).

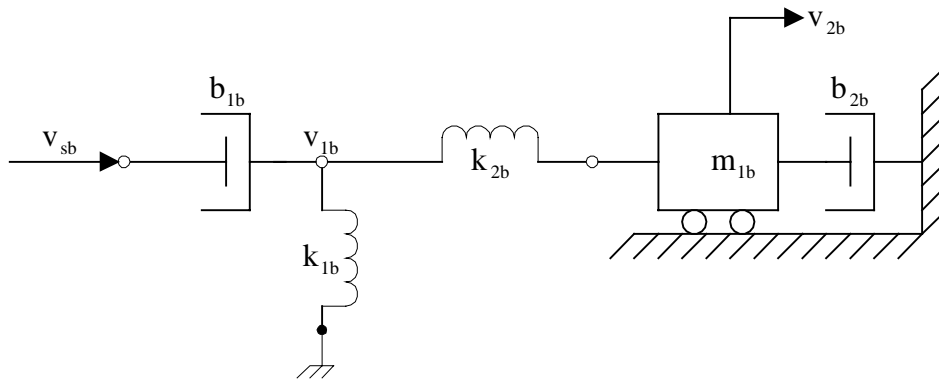

Figure 2(a) The mechanical system called N_b .

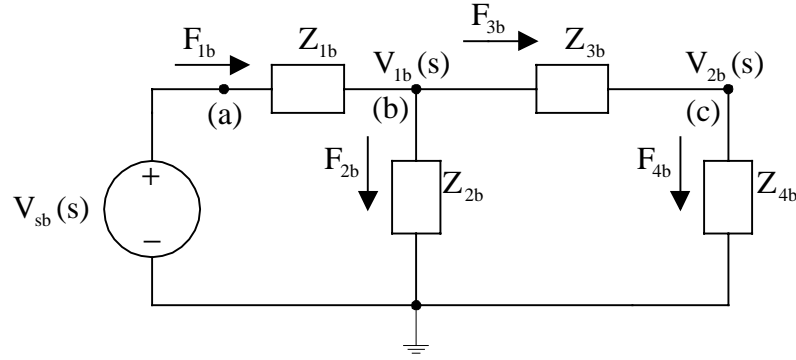

Figure 2(b) The Laplace-transform equivalent circuit of Figure 2(a)

The impedances are given by

$$Z_{1b} = b_1, Z_{2b} = \frac{s}{k_{1b}}, Z_{3b} = \frac{s}{k_{2b}} \text{ and } Z_{4b} = \frac{1}{b_{2b} + sm_{2b}} \quad (6)$$

Analysis yields

$$F_{1b}(s) = \frac{(Z_{2b} + Z_{3b} + Z_{4b})V_{sb}(s)}{Z_{1b}(Z_{2b} + Z_{3b} + Z_{4b}) + Z_{2b}(Z_{3b} + Z_{4b})} \quad (7a)$$

$$F_{2b}(s) = \frac{(Z_{3b} + Z_{4b})V_{sb}(s)}{Z_{1b}(Z_{2b} + Z_{3b} + Z_{4b}) + Z_{2b}(Z_{3b} + Z_{4b})} \quad (7b)$$

$$F_{3b}(s) = F_{4b}(s) = \frac{(Z_{4b})V_{sb}(s)}{Z_{1b}(Z_{2b} + Z_{3b} + Z_{4b}) + Z_{2b}(Z_{3b} + Z_{4b})} \quad (7c)$$

$$V_{1b}(s) = F_{2b}(s) Z_{2b} \quad (7d)$$

$$V_{2b}(s) = F_{4b}(s) Z_{4b} \quad (7e)$$

Figures 1(b) and 2(b) show that networks N_a and N_b have the same topology. It is readily verified that all the four relationships given in Equation (3) are satisfied. Specifically, Equation (3a) becomes

$$-V_{sa}F_{1a} + (V_{sa} - V_{1a})F_{1a} + V_{1a}F_{2a} + (V_{1a} - V_{2a})F_{3a} + V_{2a}F_{4a} = 0 \quad (8a)$$

Equation (3b) becomes

$$-V_{sb}F_{1b} + (V_{sb} - V_{1b})F_{1b} + V_{1b}F_{2b} + (V_{1b} - V_{2b})F_{3b} + V_{2b}F_{4b} = 0 \quad (8b)$$

Equation (3c) becomes

$$-V_{sa}F_{1b} + (V_{sa} - V_{1a})F_{1b} + V_{1a}F_{2b} + (V_{1a} - V_{2a})F_{3b} + V_{2a}F_{4b} = 0 \quad (8c)$$

Equation (3d) becomes

$$-V_{sb}F_{1a} + (V_{sb} - V_{1b})F_{1a} + V_{1b}F_{2a} + (V_{1b} - V_{2b})F_{3a} + V_{2b}F_{4a} = 0 \quad (8d)$$

Example 2 – Fluid System

Figure 3(a) depicts a fluid system which we can denote as N_a and figure 3(b) shows the electrical circuit equivalent which has the same topology as the circuit in Figure 1(b).

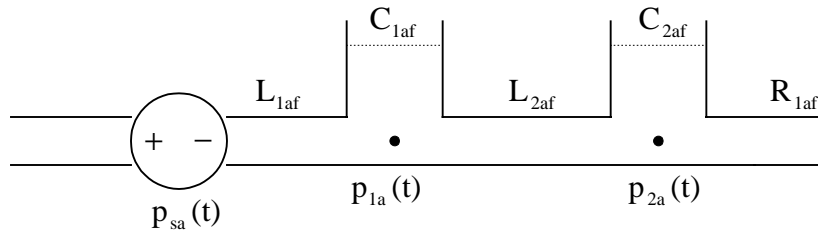

Figure 3(a) A fluid system designated as N_a

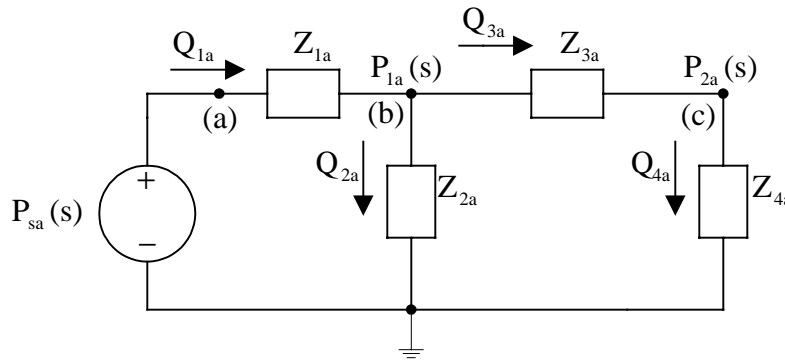

Figure 3(b) The equivalent circuit of Figure 3(a) in the Laplace transform domain

The impedances are given by

$$Z_{1a} = sL_{1af}, Z_{2a} = \frac{1}{sC_{1af}}, Z_{3a} = sL_{2af}, Z_{4a} = \frac{R_{1af}}{sC_{2af}R_{1af} + 1}$$

Figure 4(a) depicts a fluid system which we can denote as N_b and figure 4(b) shows the electrical circuit equivalent which has the same topology as the circuit in Figure 2(b). The fluid systems of this example are equivalent to the mechanical systems of example 1. The circuit topologies of the mechanical and fluid systems are all identical.

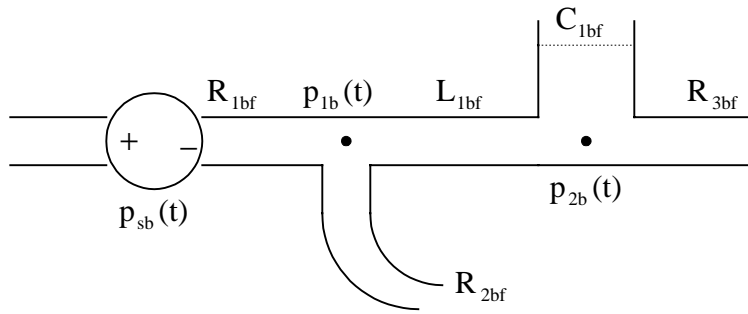

Figure 4(a) The fluid system called N_b .

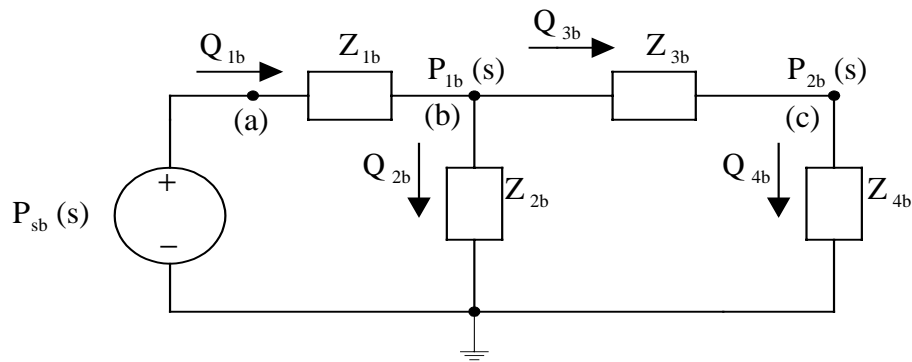

Figure 4(b) The equivalent circuit of Figure 4(a) in the Laplace transform domain

The impedances are given by

$$Z_{1b} = R_{1bf}, Z_{2b} = R_{2bf}, Z_{3b} = sL_{1bf}, Z_{4b} = \frac{R_{3bf}}{sC_{1bf}R_{3bf} + 1}$$

The analysis and verification of Tellegen's theorem proceeds in an identical manner as for Example 1.

Summary and Conclusions

In this paper, it has been shown that Tellegen's theorem, enunciated for electrical systems so far, can be applied to other types of systems like mechanical, fluid and thermal systems also. Though one example of a pair of mechanical systems and one of a pair of fluid systems are given (due to space considerations), similar examples can be given for other systems also. This paper makes a thrust at multidisciplinary engineering education by showing that a powerful theorem in circuit theory can be applied in other systems thereby further enforcing the isomorphism among various systems.

It is suggested that courses in Circuits, Statics, Dynamics and Fluids integrate Tellegen's theorem and our extension to provide students with a better insight across engineering disciplines. This will partially address the demand of industry for acquiring engineers with a broad set of skills and a comprehension of diverse practical applications and who can move across rather artificial program boundaries with great ease.

References

1. J. Choma, *Electrical Networks*, John Wiley and Sons, 1985.
2. N. Balabanian and T. Bickart, *Linear Network Theory: Analysis, Properties and Synthesis*, Matrix Publishers Inc., 1981.
3. A. V. Oppenheim and R. W. Schaffer, *Digital Signal Processing*, Prentice-Hall Inc., 1975.
4. J. F. Lindsay and V. Ramachandran, *Modeling and Analysis of Linear Physical Systems*, Weber Systems Inc., January 1991.

Biography

Ravi P. Ramachandran is an Associate Professor in the Department of Electrical and Computer Engineering at Rowan University. He received his Ph.D. from McGill University in 1990 and has worked at AT&T Bell Laboratories and Rutgers University prior to joining Rowan.

V. Ramachandran is a Professor in the Department of Electrical and Computer Engineering at Concordia University. He received his Ph.D. from the Indian Institute of Science in 1965 and was on the faculty at the Technical University of Nova Scotia prior to joining Concordia.